

SBE 5T (titanium) & SBE 5P (plastic) Submersible Pump

The SBE 5T / 5P pump is a modular component on several Sea-Bird CTD packages. The 5T / 5P is standard equipment on the SBE 9plus CTD and 25 / 25plus Sealogger CTD, and optional equipment on the SBE 16plus V2, 16plus-IM V2, and 19plus V2 SeaCAT CT(D) Recorders. The highly reliable pump flushes water through the conductivity cell at a constant rate, independent of the CTD's motion, improving dynamic performance. Operational characteristics of the 5T and 5P are identical, but the housings and depth ratings differ (5T titanium housing to 10,500 m; 5P plastic housing to 600 m).

The pump may also be suitable for custom applications, where pressure heads are less than 300 cm of water and flow rates are less than 100 ml/sec.



Features

- Centrifugal pump head.
- Long-life, brushless, DC, ball-bearing motor.
- Pump impeller and electric drive motor coupled magnetically through housing, providing high reliability by eliminating moving seals.
- Pumping rates and motor current for various applications.
- Five-year limited warranty.

Options

- Voltage/power and RPM selections – Pump is configured by selecting voltage range, and one of several motor speed options (1300, 2000, 3000, and 4500 rpm speeds have been established to meet various flow requirements; other speeds can be set by adjusting a potentiometer). Typical settings include:
 - #3 winding, 10-18 VDC, 2000 rpm – typical for SBE 16plus V2, 16plus-IM V2, or 19plus V2 with pumped auxiliary sensor(s), and for SBE 25plus
 - #3 winding, 10-18 VDC, 3000 rpm – typical for SBE 9plus
 - #3 winding, 6-16 VDC, 2000 rpm – typical for SBE 25
- Plastic (600 m) or titanium (10,500 m) housing.
- XSG or wet-pluggable MCBH connector.

Operation

Motor speed and pumping rate remain nearly constant over the entire input voltage range (< 1% change in speed for 1-volt supply voltage change). Unrestricted flow rate with no head is 100 ml/sec* at 2000 rpm. Flow changes are nearly linear with speed changes. With unlimited supply current, turn-on surge is 1.8 A* maximum, dropping to steady state in 0.25 sec*. If power supply current is limited to 200 mA*, the motor comes up to speed in 0.30 sec*. A series diode is installed in the input power line to prevent damage if wires are accidentally reversed.

* approximate

Mechanical

SBE 5P	Plastic housing; 600 m; Weight in air 0.5 kg, in water 0.1 kg
SBE 5T	Titanium housing; 10,500 m; Weight in air 0.7 kg, in water 0.3 kg

Performance

#3 winding; 1300 - 3000 RPM	Input voltage range 10 - 18 VDC
#3 winding; 4500 RPM	Input voltage range 12 - 18 VDC
#3 or #5 winding; 1300, 2000 RPM only	Input voltage range 6 - 16 VDC

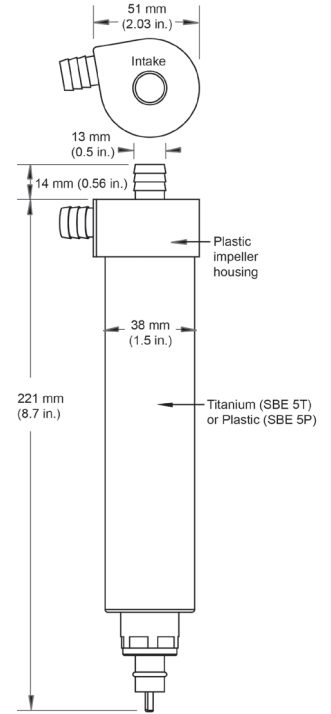

Voltage vs Current Draw

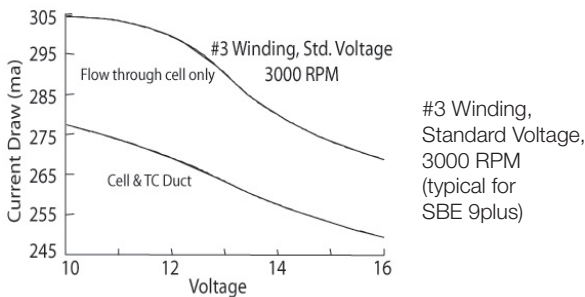
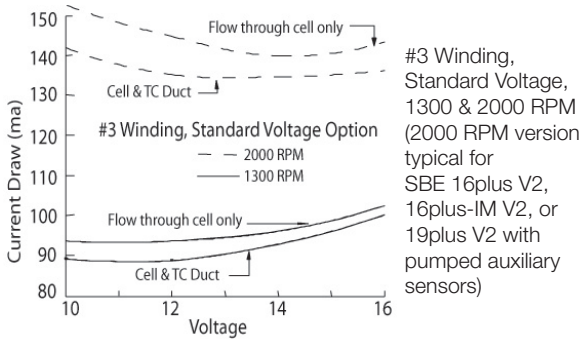
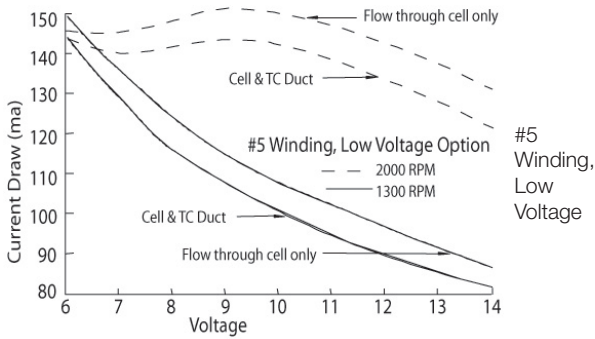

Flow through cell only:

Voltage (V)	Current Draw (mA)
12	640
15	585

#3 Winding, Standard Voltage, 4500 RPM

Pump Speed

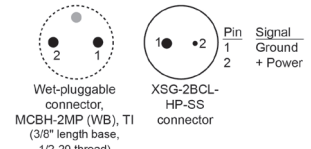
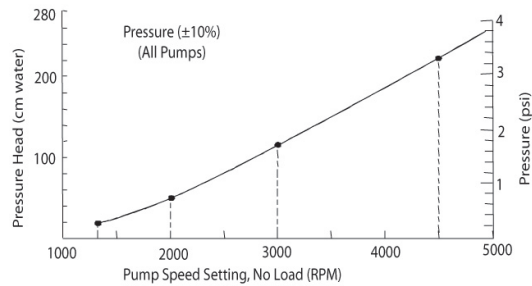
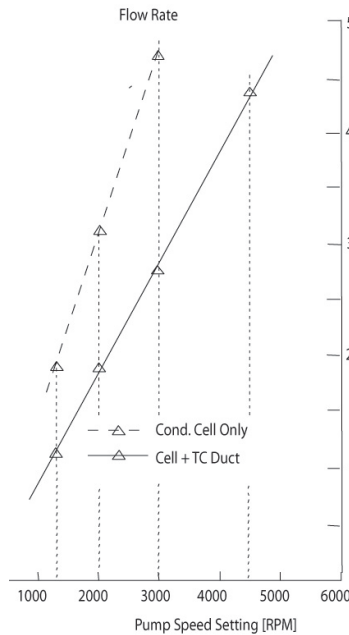

Pump Speed Setting vs. Flow Rate (typical for SBE 9plus, 25, and 25plus)

Pump Speed Setting vs. Pressure

Specifications subject to change without notice. ©2016 Sea-Bird Scientific. All rights reserved. Rev. June 2016