



OPTIFLUX 5000 Technical Datasheet

Electromagnetic flowmeter in flanged version

- Exceptional long-term stability and accuracy
- For highly aggressive and abrasive fluids
- Fully vacuum-resistant with high-tech ceramics liner



The documentation is only complete when used in combination with the relevant documentation for the signal converter.

1	Product features	3
<hr/>		
1.1	Solution with high-tech ceramics	3
1.2	Options and variants	5
1.3	Measuring principle.....	6
2	Technical data	7
<hr/>		
2.1	Technical data.....	7
2.2	Dimensions and weights	12
2.3	Measuring accuracy	17
3	Installation	18
<hr/>		
3.1	Intended use	18
3.2	General notes on installation	18
3.2.1	Vibrations	18
3.2.2	Magnetic field.....	18
3.3	Installation conditions	19
3.3.1	Inlet and outlet	19
3.3.2	Bends in 2 or 3 dimensions.....	19
3.3.3	T-section	20
3.3.4	Bends	20
3.3.5	Open discharge	21
3.3.6	Control valve	21
3.3.7	Pump	21
3.3.8	Air venting and vacuum forces	22
3.3.9	Flange deviation.....	23
3.3.10	Mounting position.....	23
3.4	Mounting	24
3.4.1	Torques and pressures.....	24
4	Electrical connections	26
<hr/>		
4.1	Safety instructions.....	26
4.2	Grounding	26
4.3	Virtual reference for IFC 300 (C, W and F version)	27
4.4	Connection diagrams	27

1.1 Solution with high-tech ceramics

The **OPTIFLUX 5000** electromagnetic flowmeter provides the optimum in accuracy, repeatability and long term stability. This is achieved with a special tube design from high-tech ceramic zirconium oxide. Leading metrological institutes reflect this as they frequently use the **OPTIFLUX 5000** as their master meter.

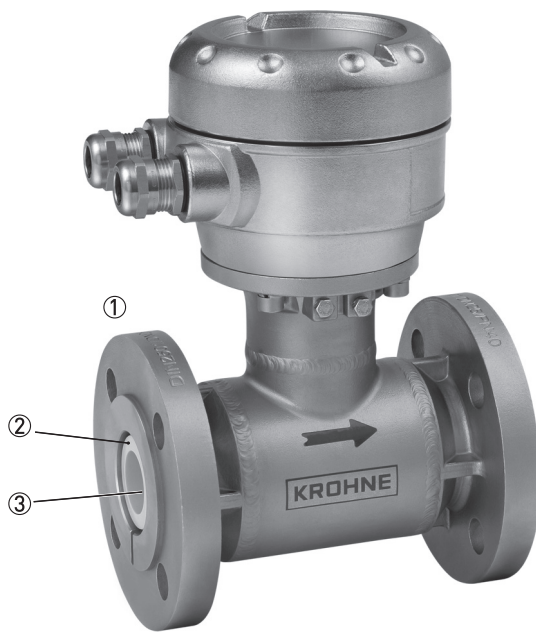

- ① Flanged design
- ② Ceramic tube
- ③ Cermet or Platinum electrodes

Ceramic durability

By implementing oxide ceramic sensors into OPTIFLUX and BATCHFLUX electromagnetic flowmeters as well as ceramic diaphragms into OPTIBAR pressure devices, KROHNE is using a superior material that is permanently resistant to corrosive and abrasive media and also immune to temperature shocks.

durability

Highlights

- Exceptional long-term stability and accuracy
- Unique flow tube
- Fused in-place Cermet or Platinum electrodes
- For highly aggressive and abrasive fluids
- Fully vacuum-resistant
- High-tech ceramics liner
- Insensitive against temperature shocks
- Optional conductive PTFE gaskets to omit grounding rings

Industries

- Chemical
- Paper & pulp
- Water & wastewater
- Minerals & mining
- Food & beverage
- Machinery

Applications

- Master transfer meter
- Precise volumetric dosing of additives
- Chemical injection
- For acids, alkaline, abrasive slurries and many other aggressive media

1.2 Options and variants



The **OPTIFLUX 5000** in flanged version is available in a diameter range of DN15 up to DN300/ ½ up to 12".

The flow sensor is offered in a large range of pressure ratings and is configurable with the IFC 050, IFC 100 and the IFC 300 signal converter.

The flow meter can be ordered in stainless steel version and is also optionally suitable in hazardous areas.

The installation of the OPTIFLUX 5000 can be simplified by choosing the virtual reference option. Grounding rings can then be omitted. This can only be combined with the IFC 300 signal converter.

1.3 Measuring principle

An electrically conductive fluid flows inside an electrically insulated pipe through a magnetic field. This magnetic field is generated by a current, flowing through a pair of field coils.

Inside of the fluid, a voltage U is generated:

$$U = v * k * B * D$$

in which:

v = mean flow velocity

k = factor correcting for geometry

B = magnetic field strength

D = inner diameter of flowmeter

The signal voltage U is picked off by electrodes and is proportional to the mean flow velocity v and thus the flow rate Q . A signal converter is used to amplify the signal voltage, filter it and convert it into signals for totalizing, recording and output processing.

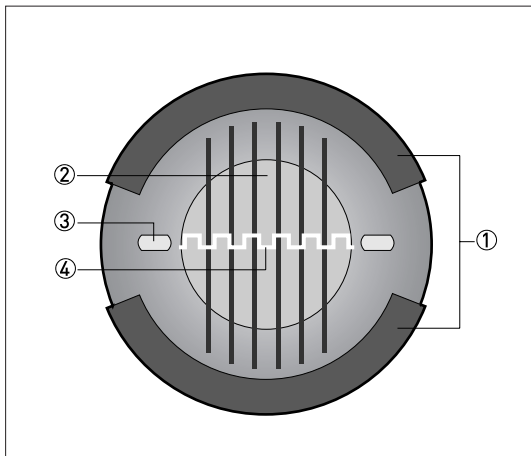

Figure 1-1: Measuring principle

- ① Field coils
- ② Magnetic field
- ③ Electrodes
- ④ Induced voltage (proportional to flow velocity)

2.1 Technical data

- *The following data is provided for general applications. If you require data that is more relevant to your specific application, please contact us or your local sales office.*
- *Additional information (certificates, special tools, software,...) and complete product documentation can be downloaded free of charge from the website (Downloadcenter).*

Measuring system

Measuring principle	Faraday's law of induction
Application range	Electrically conductive fluids
Measured value	
Primary measured value	Flow velocity
Secondary measured value	Volume flow, mass flow, electrical conductivity, coil temperature

Design

Features	Flanged version with optimized flow tube
Modular construction	The measurement system consists of a flow sensor and a signal converter. It is available as compact and as separate version. More information about the signal converter can be found in the relevant documentation.
Compact version	With IFC 050 signal converter : OPTIFLUX 5050 C
	With IFC 100 signal converter: OPTIFLUX 5100 C
	With IFC 300 signal converter : OPTIFLUX 5300 C
Remote version	In wall (W) mount version with IFC 050 signal converter: OPTIFLUX 5050 W
	In wall (W) mount version with IFC 100 signal converter: OPTIFLUX 5100 W
	In field (F), wall (W) or rack (R) mount version with IFC 300 signal converter: OPTIFLUX 5300 F, W or R
Nominal diameter	DN15...300 / ½...12"

Measuring accuracy

Maximum measuring error	IFC 050: down to 0.5% of the measured value ± 1 mm/s
	IFC 100: down to 0.3% of the measured value ± 1 mm/s
	IFC 300: down to 0.15% of the measured value ± 1 mm/s
	The maximum measuring error depends on the installation conditions
	For detailed information refer to <i>Measuring accuracy</i> on page 17.
Repeatability	$\pm 0.1\%$ of MV, minimum 1 mm/s
Long term stability	$\pm 0.1\%$ of MV
Special calibration	On request

Operating conditions

Temperature	
Process temperature	Compact version: -40...+140°C / -40...+284°F
	Remote version: -40...+180°C / -40...+356°F
	For Ex versions different temperatures are valid. Please check the relevant Ex documentation for details.
Maximum temperature change (shock)	DN2.5...25 / 1/10...1": < 3 K/s
Ambient temperature	Standard: -40...+65°C / -40...+149°F
	Option: stainless steel version: -40...+55°C / -40...+130°F
	For Ex versions different temperatures are valid. Please check the relevant Ex documentation for details.
Protect electronics against self-heating at ambient temperatures above +55°C / +131°F.	
Storage temperature	-50...+70°C / -58...+158°F
Measurement range	-12...+12 m/s / -40...+40 ft/s
Pressure	
Ambient	Atmospheric
Nominal flange pressure	Standard:
EN 1092-1	DN200...300: PN 10
	DN100...150: PN 16
	DN15...80: PN 40
ASME B16.5	Standard:
	1...12": 150 lb
	½": 300 lb
	Option:
	1", 2", 3": 300 lb
Vacuum load	0 mbar / 0 psi
Pressure ranges for secondary containment	Pressure resistant up to 40 bar / 580 psi
	Burst pressure up to approximately 160 bar / 2320 psi
Chemical properties	
Physical condition	Conductive liquids
Electrical conductivity	Non water:
	DN25...300 / 1...12": ≥ 1 µS/cm
	DN15 / ½": ≥ 5 µS/cm
	Demineralised cold water
	DN15...300 / ½...12": ≥ 20 µS/cm
Permissible gas content (volume)	IFC 050: ≤ 3% IFC 100 and IFC 300: ≤ 5%
Permissible solid content (volume)	IFC 050 and IFC 100: ≤ 10%
	IFC 300: ≤ 70%

Installation conditions

Installation	Assure that the flow sensor is always fully filled
	For detailed information refer to <i>Installation</i> on page 18.
Flow direction	Forward and reverse
	Arrow on flow sensor indicates positive flow direction
Inlet run	≥ 5 DN (without disturbing flow, after a single 90° bend)
	≥ 10 DN (after a double bend = 2 x 90°)
Outlet run	≥ 2 DN
Dimensions and weights	For detailed information refer to <i>Dimensions and weights</i> on page 12.

Materials

Flow sensor housing	DN15...100 / ½...4": stainless steel AISI 316 / 1.4408
	DN150...300 / 6...12": sheet steel (carbon steel)
Flow sensor	Ceramic
Connection box (only remote versions)	Standard: die-cast aluminium
	Option: stainless steel
	Standard coating
Grounding rings	Standard:
	Not included
	Option:
	Virtual reference: only with IFC 300 signal converter
Gaskets	PTFE, white
	Option: filled PTFE, blue (L-type) 25% carbon graphite filled PTFE, grey; Gylon 3504, blue
Measuring electrodes	Standard:
	Cermet

Process connections

EN 1092-1	DN200...300: PN 10
	DN100..150: PN 16
	DN15...80: PN 40
ASME	Standard:
	1...12": 150 lb
	½": 300 lb
	Option:
	1", 2", 3": 300 lb

Electrical connections

For full detail, see the relevant documentation of the signal converter.	
Signal cable for remote systems only.	
Type A (DS)	In combination with the IFC 050, IFC 100 and IFC 300 signal converter.
	Standard cable, double shielded. Max. length: 600 meter / 1950 feet (depends on the electrical conductivity and flow sensor).
Type B (BTS)	Only in combination with the IFC 300 signal converter
	Optional cable, triple shielded. Max. length: 600 meter / 1950 feet (depends on electrical conductivity and flow sensor).
I/O	For more details of the I/O options, including data streams and protocols, see technical data of the relevant signal converter.

Approvals and certifications

CE mark	
This device fulfils the statutory requirements of the EU directives. The manufacturer certifies successful testing of the product by applying the CE mark.	
	For more information on the EU directives & standards and the approved certifications, please refer to the EU Declaration of Conformity or the manufacturer website.
Hazardous areas	
ATEX	Please check the relevant Ex documentation for details.
	In combination with IFC 050 and IFC 100 signal converter: II 2 GD
	In combination with IFC 300 signal converter: II 2 GD or II 2 (1) GD
	Remote version: II 2 GD
	Consult IFC 300 manual for EEx i and non-EEx i I/O modules
FM	Only for diameters DN15...100 / ½...4"
	In combination with IFC 300 C or F signal converter
	Class I, Div. 2, groups A, B, C and D
	Class II, Div. 2, groups F and G
	Class III, Div. 2
CSA	Only for diameters DN15...100 / ½...4"
	In combination with IFC 300 C or F signal converter
	Class I, Div. 2; groups A, B, C and D
	Class II, Div. 2; groups F and G
IEC-Ex	pending
NEPSI	OPTIFLUX 5000 F: GYJ101206
	Ex me ia IIC T6...T3
	OPTIFLUX 5300 C: GYJ101207
	Ex de ia IIC T6...T3
Other approvals and standards	
Custody transfer	Standard: without verification
	Only in combination with IFC 300 signal converter.
	Option: MI-001, MI-005 type examination certificate
Protection category acc. to IEC 60529	Standard: IP66/67, NEMA 4/4X/6 IFC 100 stainless steel: IP67/69
	Option: IP68, NEMA 6P
Hygiene	Ceramic tube: FDA approved material
Shock test	IEC 60068-2-27
	30 g for 18 ms
Vibration test	IEC 60068-2-64
	f = 20...2000 Hz, rms = 4.5 g, t = 30 min

2.2 Dimensions and weights

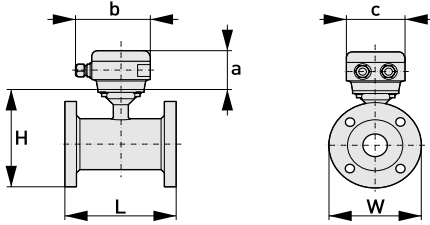
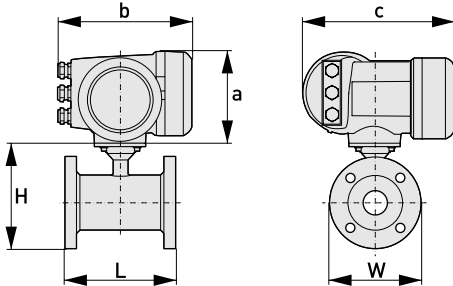
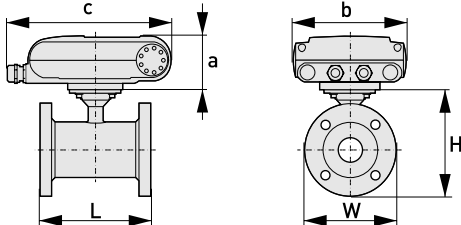
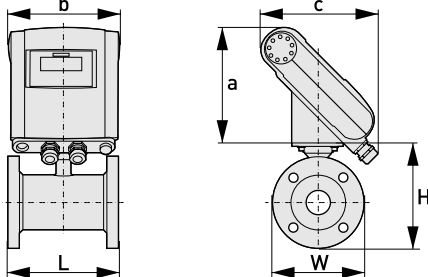
<p>Remote version</p>		<p>a = 88 mm / 3.5"</p> <p>b = 139 mm / 5.5" ①</p> <p>c = 106 mm / 4.2"</p> <p>Total height = H + a</p>
<p>Compact version with: IFC 300</p>		<p>a = 155 mm / 6.1"</p> <p>b = 230 mm / 9.1" ①</p> <p>c = 260 mm / 10.2"</p> <p>Total height = H + a</p>
<p>Compact version with: IFC 100 (0°)</p>		<p>a = 82 mm / 3.2"</p> <p>b = 161 mm / 6.3"</p> <p>c = 257 mm / 10.1" ①</p> <p>Total height = H + a</p>
<p>Compact version with: IFC 100 (45°)</p>		<p>a = 186 mm / 7.3"</p> <p>b = 161 mm / 6.3"</p> <p>c = 184 mm / 7.3" ①</p> <p>Total height = H + a</p>

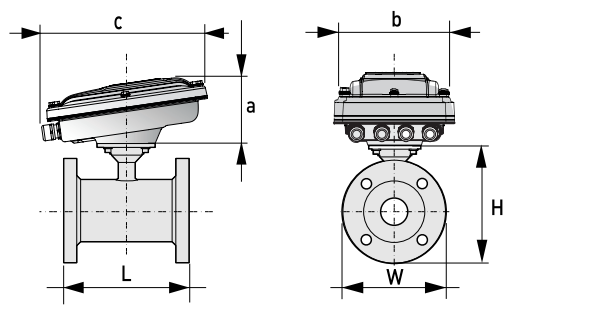
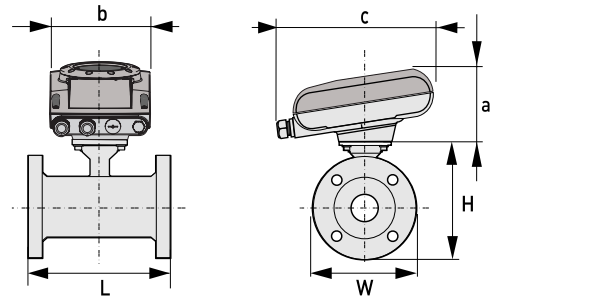
Compact version with stainless steel IFC 100 (10°)		<p>a = 100 mm / 4"</p> <p>b = 187 mm / 7.36" ①</p> <p>c = 270 mm / 10.63"</p> <p>Total height = H + a</p>
Compact version with: IFC 050 (10°)		<p>a = 100mm / 4"</p> <p>b = 157 mm / 6.18" ①</p> <p>c = 260 mm / 10.24"</p> <p>Total height = H + a</p>

① The value may vary depending on the used cable glands.

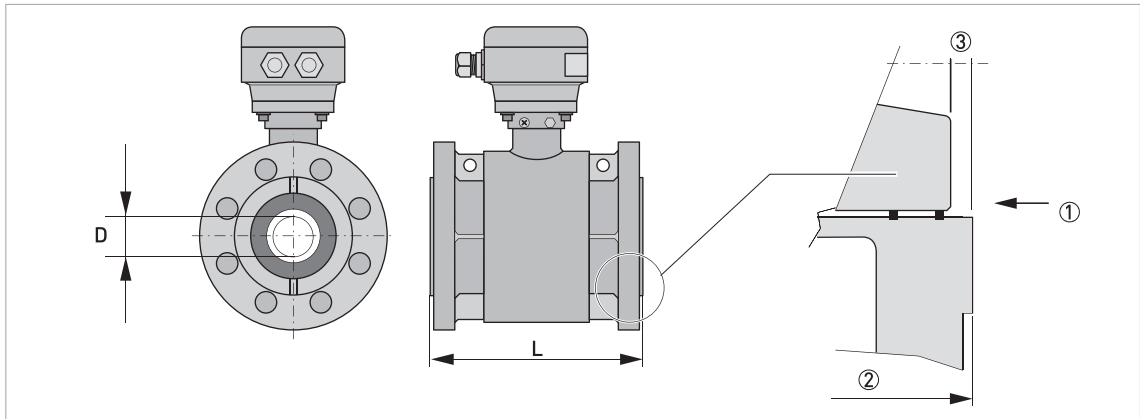

Figure 2-1: Construction details

- ① Detail ceramics, flange and gaskets, see options in following illustration
- ② Length tolerances (see table on following pages)
- ③ Gasket area

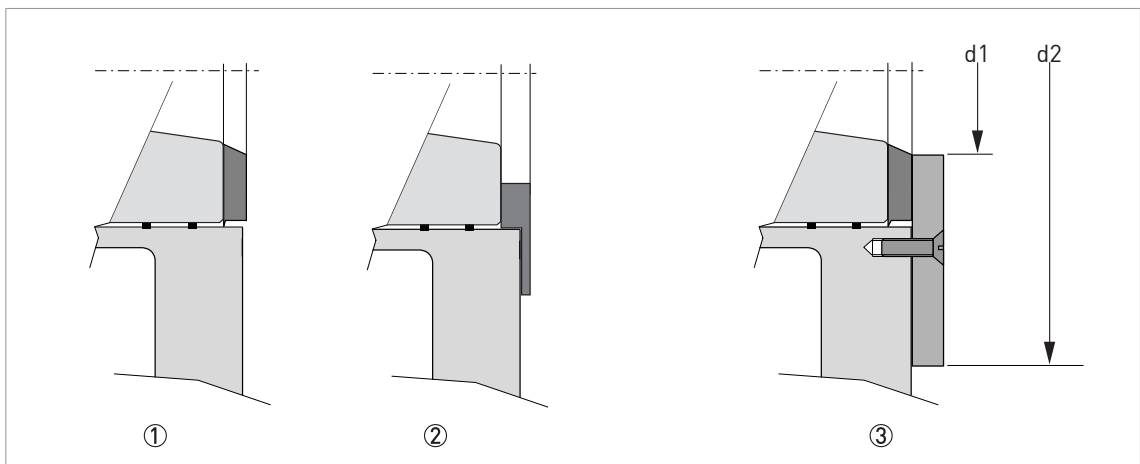

Figure 2-2: Details of gasket options

- ① Sealing ring: PTFE (white)
Optional: conductive PTFE (grey) / Gylon 3504 (blue)
- ② Sealing ring for rounded counter flanges: filled PTFE (blue)
- ③ DN150...300 / 6...12"; optional spacer ring with gasket

- All data given in the following tables are based on standard versions of the flow sensor only.
- Especially for smaller nominal sizes of the flow sensor, the signal converter can be bigger than the sensor.
- Note that for other pressure ratings than mentioned, the dimensions may be different.
- For full information on signal converter dimensions see relevant documentation.

EN 1092-1

Size	Dimensions [mm]							Approx. weight [kg]
DN	L + *	tolerance	H	W	D	Ød1	Ød2	
15	150	A	127	95	12	-	-	3
25	150	A	143	115	20	-	-	4
40	150	A	168	150	30	-	-	6
50	200	A	184	165	40	-	-	9
80	200	A	217	200	60	-	-	15
100	250	A	242	220	80	-	-	21
150	250	B	355	283	150	150	215	37
200	300	B	396	342	200	198	270	53
250	350	B	458	395	250	250	322	87
300	450	B	493	445	300	300	375	145

*L + **

- Add approximately 2 x 7.5 mm to L when using spacer rings (option for DN150...300).
- Add approximately 2 x 1.45 mm to L when using filled blue PTFE gaskets (optional).

Tolerances A & B

- A = + 0.8 / - 0.4 mm; + 0.031 / - 0.016 inches
- B = + 0.5 / - 1.0 mm; + 0.02 / - 0.04 inches

ASME B 16.5 150 lb

Size	Dimensions [inches]							Approx. weight [lb]
inch	L + *	tolerance	H	W	D	Ød1	Ød2	
1"	5.91	A	5.47	4.25	0.79	-	-	8.8
1½"	5.91	A	6.18	5	1.18	-	-	13.2
2"	7.87	A	6.89	6	1.57	-	-	19.8
3"	7.87	A	8.39	7.5	2.36	-	-	33.1
4"	9.84	A	9.65	9	3.15	-	-	46.3
6"	9.84	B	13.98	11	5.91	6.06	8.46	81.6
8"	11.81	B	15.59	13.5	7.80	7.99	10.63	116.8
10"	13.78	B	18.03	16	9.84	10.08	12.68	191.8
12"	17.72	B	19.41	19	11.81	12.05	14.76	366

ASME B 16.5 300 lb

Size	Dimensions [inches]							Approx. weight [lb]
inch	L + *	tolerance	H	W	D	Ød1	Ød2	
½"	5.91	A	5.0	3.74	0.47	-	-	6.8
1"	5.91	A	5.91	4.92	0.79	-	-	8.8
2"	7.87	A	7.20	6.50	1.57	-	-	22.9
3"	7.87	A	8.86	8.27	2.36	-	-	40.6
1½": not possible because of ASTM-NUT								

*L + **

- Add approximately 2 x 0.3" to L when using spacer rings (option for 6"...12").
- Add approximately 2 x 0.055" to L when using filled blue PTFE gaskets (optional).

Tolerances A & B

- A = + 0.8 / - 0.4 mm; + 0.031 / - 0.016 inches
- B = + 0.5 / - 1.0 mm; + 0.02 / - 0.04 inches

- Pressures at 20°C / 68°F.
- For higher temperatures, the pressure and temperature ratings are as per ASME B16.5.

2.3 Measuring accuracy

Every electromagnetic flowmeter is calibrated by direct volume comparison. The wet calibration validates the performance of the flowmeter under reference conditions against accuracy limits.

The accuracy limits of electromagnetic flowmeters are typically the result of the combined effect of linearity, zero point stability and calibration uncertainty.

Reference conditions

- Medium: water
- Temperature: +5...+35°C / +41...+95°F
- Operating pressure: 0.1...5 barg / 1.5...72.5 psig
- Inlet section: ≥ 5 DN
- Outlet section: ≥ 2 DN

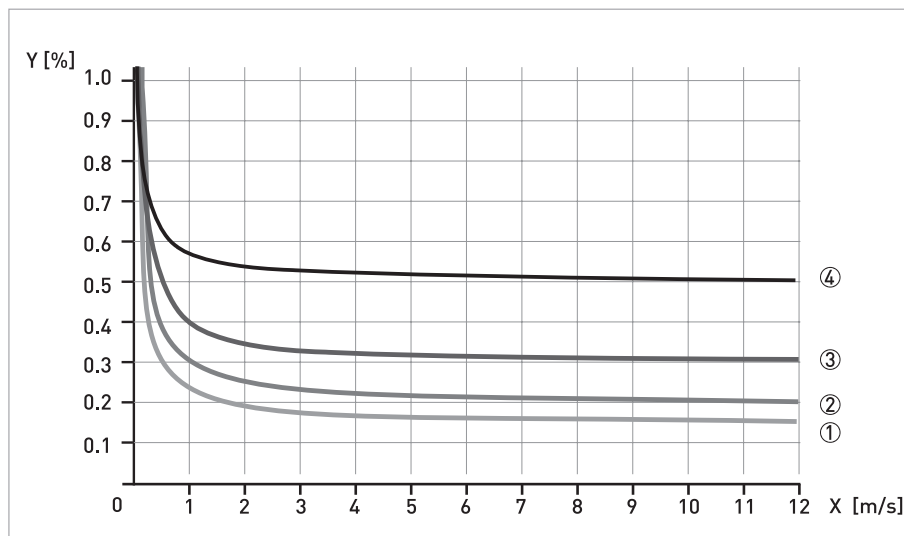

X [m/s]: flow velocity

Y [%]: deviation from the actual measured value (MV)

Accuracy

Compact with IFC 300	Accuracy	Curve
DN15...100 / ½...4"	$\pm 0.15\%$ of MV + 1 mm/s	①
DN150...300 / 6...12"	$\pm 0.2\%$ of MV + 1 mm/s	②

Compact with IFC 100	Accuracy	Curve
DN15...300 / ½...12"	$\pm 0.3\%$ of MV + 1 mm/s	③

Compact with IFC 050	Accuracy	Curve
DN15...300 / ½...12"	$\pm 0.5\%$ of MV + 1 mm/s	④

Optionally for IFC 050 and IFC 100; extended calibration at 2 points for optimised accuracy. For more details on optimised accuracy, see the concerning signal converter documentation.

3.1 Intended use

Responsibility for the use of the measuring devices with regard to suitability, intended use and corrosion resistance of the used materials against the measured fluid lies solely with the operator.

The manufacturer is not liable for any damage resulting from improper use or use for other than the intended purpose.

The **OPTIFLUX 5000** flowmeter measures the volumetric flow rate of electrically conductive liquids, acids, alkaline solutions, pastes and slurries, also with very high solid contents.

3.2 General notes on installation

Inspect the packaging carefully for damages or signs of rough handling. Report damage to the carrier and to the local office of the manufacturer.

Do a check of the packing list to make sure that you have all the elements given in the order.

Look at the device nameplate to ensure that the device is delivered according to your order. Check for the correct supply voltage printed on the nameplate.

3.2.1 Vibrations

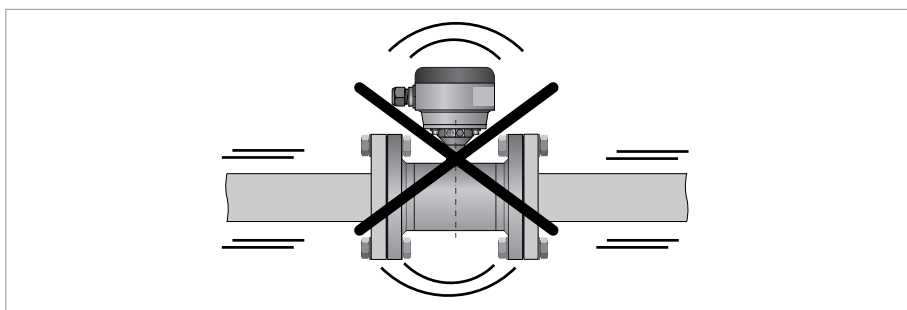

Figure 3-1: Avoid vibrations

3.2.2 Magnetic field

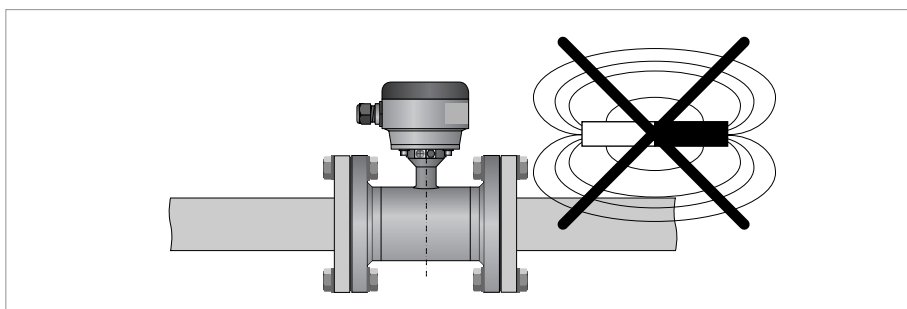

Figure 3-2: Avoid magnetic field

3.3 Installation conditions

3.3.1 Inlet and outlet

Use straight inlet and outlet pipe sections to prevent flow distortion or swirl, caused by bends and T-sections.

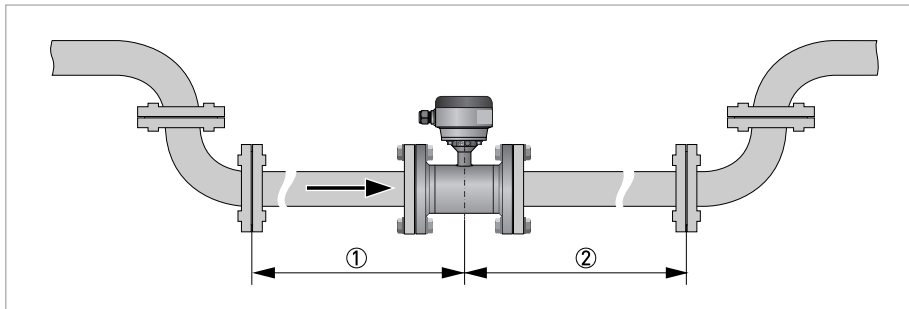

Figure 3-3: Recommended inlet and outlet section

- ① Refer to chapter "Bends in 2 or 3 dimensions"
- ② ≥ 2 DN

3.3.2 Bends in 2 or 3 dimensions

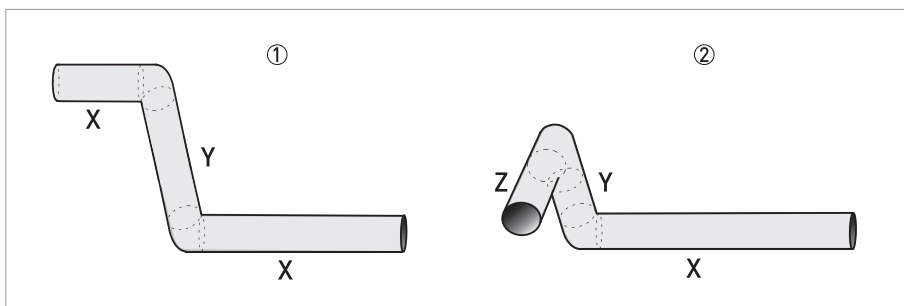

Figure 3-4: 2 and/or 3 dimensional bends upstream of the flowmeter

- ① 2 dimensions = X/Y

- ② 3 dimensions = X/Y/Z

Inlet length: using bends in 2 dimensions: ≥ 5 DN; when having bends in 3 dimensions: ≥ 10 DN

*2 dimensional bends occur in a vertical **or** horizontal plane (X/Y) only, while 3 dimensional bends occur in both vertical **and** horizontal plane (X/Y/Z).*

3.3.3 T-section

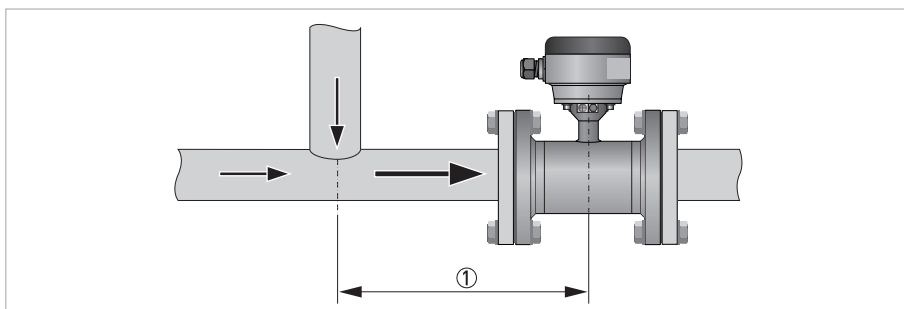

Figure 3-5: Distance behind a T-section

① ≥ 10 DN

3.3.4 Bends

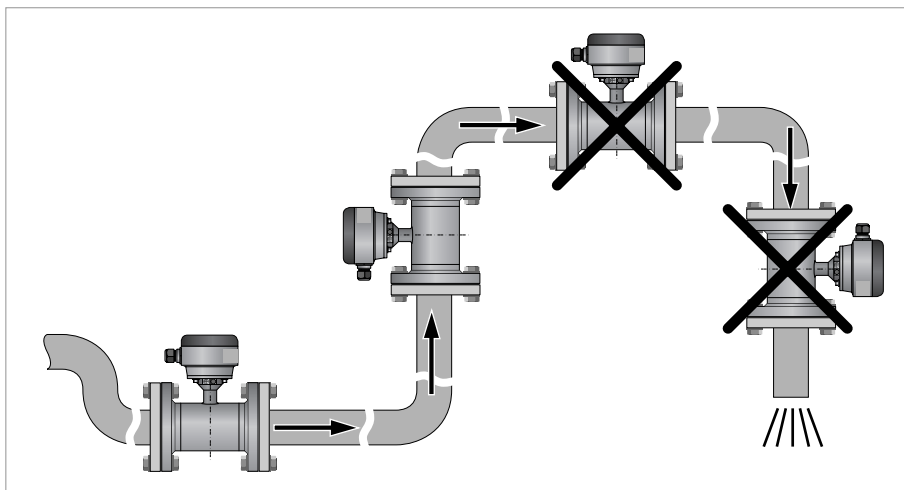

Figure 3-6: Installation in bending pipes (90°)

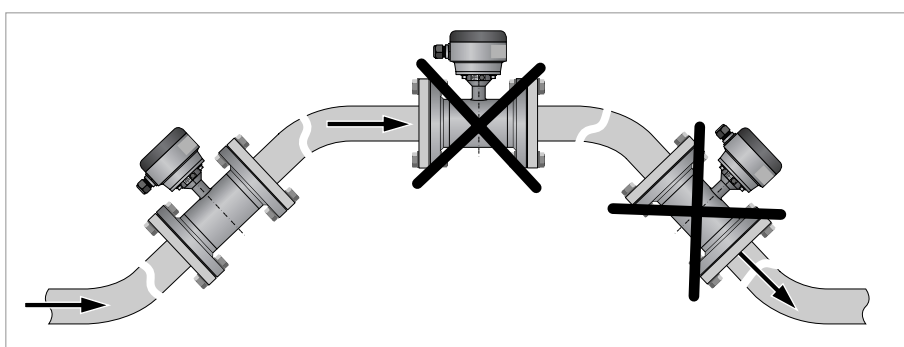

Figure 3-7: Installation in bending pipes (45°)

Avoid draining or partial filling of the flow sensor

3.3.5 Open discharge

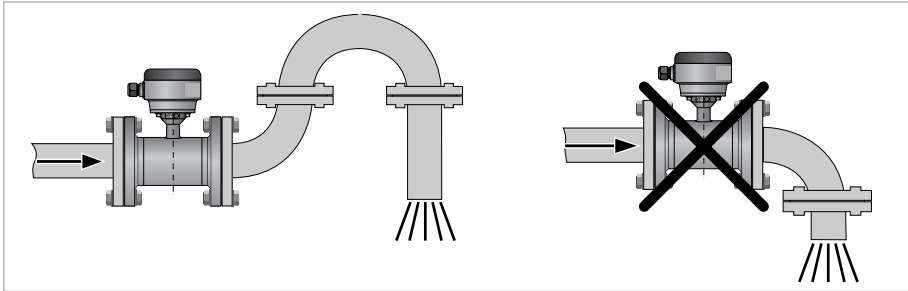

Figure 3-8: Installation in front of an open discharge

3.3.6 Control valve

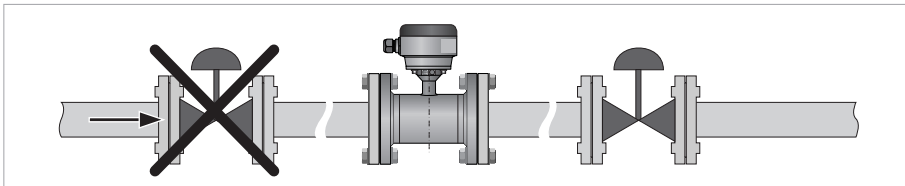

Figure 3-9: Installation in front of a control valve

3.3.7 Pump

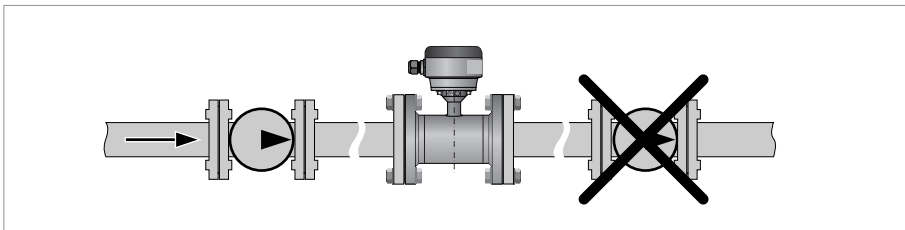

Figure 3-10: Installation behind a pump

3.3.8 Air venting and vacuum forces

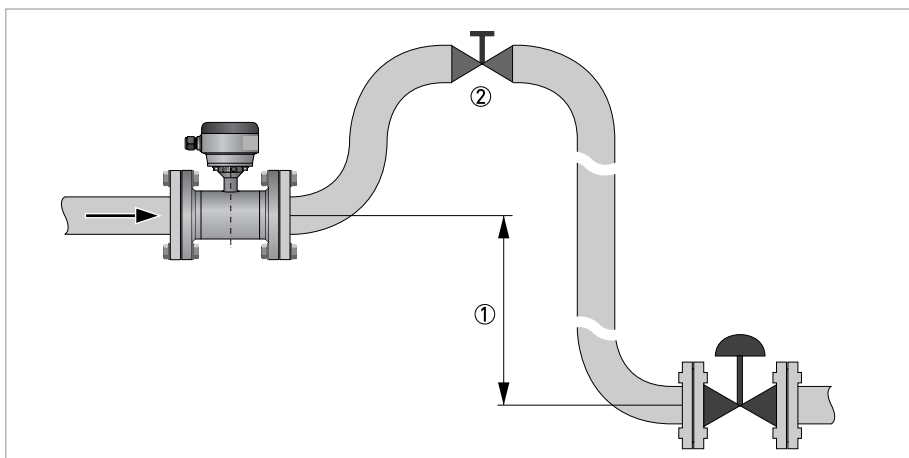

Figure 3-11: Air venting

① ≥ 5 m / 17 ft

② Air ventilation point

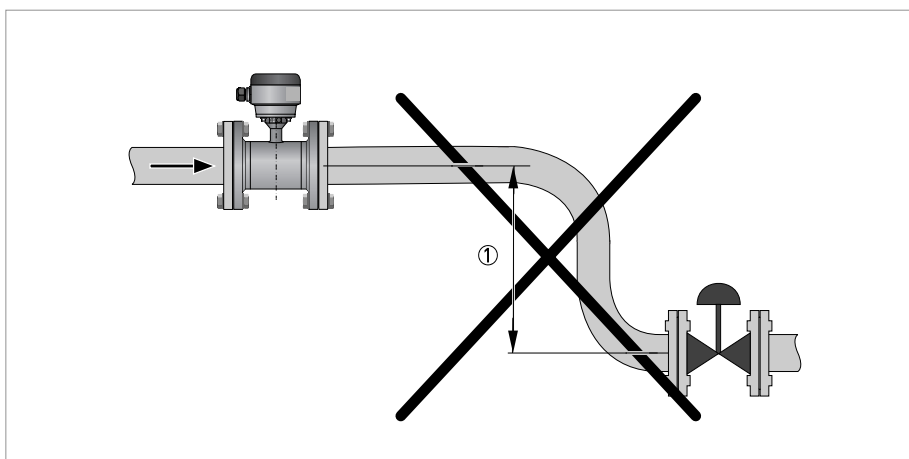

Figure 3-12: Vacuum

① ≥ 5 m / 17 ft

3.3.9 Flange deviation

Max. permissible deviation of pipe flange faces:
 $L_{max} - L_{min} \leq 0.5 \text{ mm} / 0.02''$

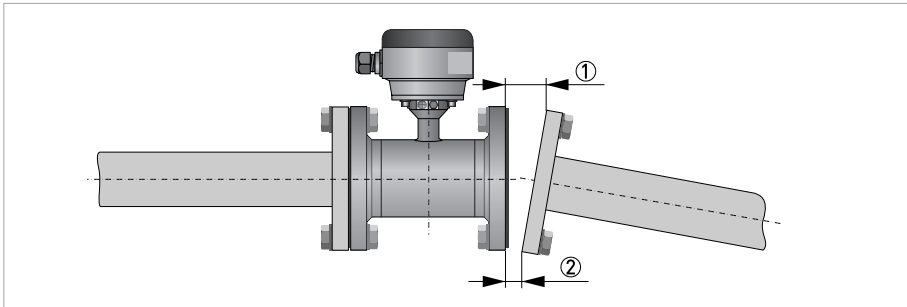

Figure 3-13: Flange deviation

- ① L_{max}
- ② L_{min}

3.3.10 Mounting position

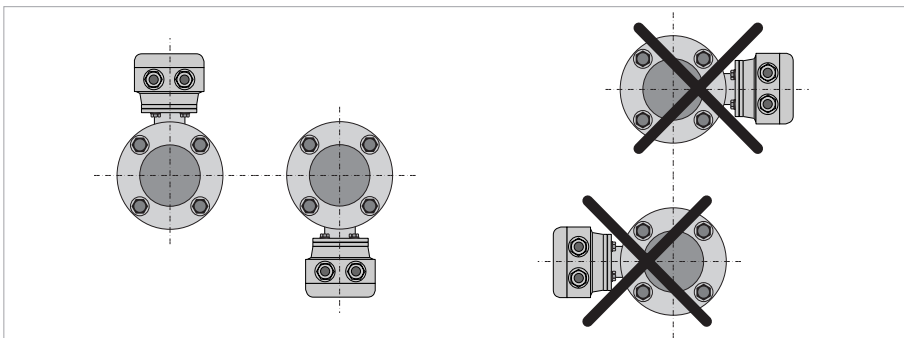

Figure 3-14: Mounting position

3.4 Mounting

Please take care to use the proper gasket to prevent damaging the liner of the flowmeter. In general, the use of spiral wound gaskets is not advised, as it could severely damage the liner of the flowmeter.

3.4.1 Torques and pressures

Tighten the bolts in fixed order, see picture:

- Step 1: by hand
- Step 2: approx. 10% of max. torque
- Step 3: approx. 25% of max. torque
- Step 4: approx. 50% of max. torque
- Step 5: approx. 80% of max. torque
- Step 6: 100% of max. torque given in table

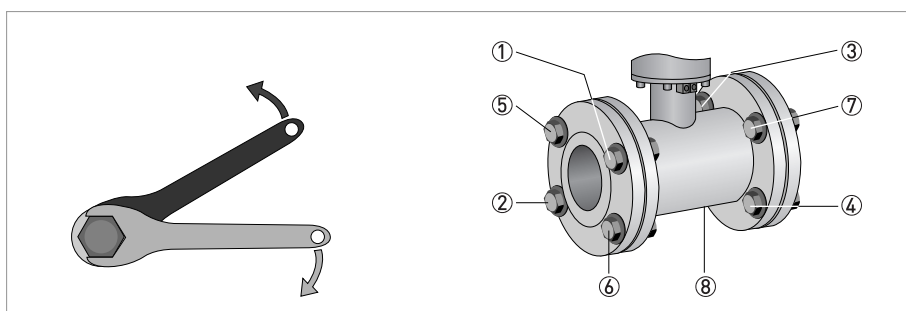

Diameters DN80 to DN300 have more bolts than the drawing in the picture above shows. Please continue in the same sequence to tighten the other bolts.

With the instrument, 4 PTFE gaskets are delivered (2 gaskets to be used with installation, 2 as spare). There are no other gaskets required.

The specified torque values are dependent on variables (temperature, bolt material, gasket material, lubricants, etc.) which are not within the control of the manufacturer. Therefore the values should be regarded as indicative only.

The torque values in the following tables are based 8.8 bolts and a friction coefficient 0.14.

EN 1092-1

Nominal size DN [mm]	Pressure rating	Bolts	Recommended torque [Nm]	
			Min.	Max.
15	PN 40	4 x M 12	50	70
25	PN 40	4 x M 12	50	70
40	PN 40	4 x M 16	100	175
50	PN 40	4 x M 16	100	175
80	PN 40	8 x M 16	100	175
100	PN 16	8 x M 16	100	175
150	PN 16	8 x M 20	200	340
200	PN 10	8 x M 20	200	340
250	PN 10	12 x M 20	250	340
300	PN 10	12 x M 20	250	340

ASME B 16.5

Nominal size [inch]	Flange class [lb]	Bolts	Recommended torque [ftlb]	
			Min.	Max.
½	300	4 x ½"	40	80
1	150 / 300	4 x ½"	40	80
1 ½	150 / 300	4 x ½"	60	80
2	150 / 300	4 x 5/8"	80	160
3	150 / 300	4 x 5/8"	100	160
4	150	8 x 5/8"	100	160
6	150	8 x ¾"	150	280
8	150	8 x ¾"	200	280
10	150	12 x 7/8"	250	450
12	150	12 x 7/8"	300	450

4.1 Safety instructions

*All work on the electrical connections may only be carried out with the power disconnected.
Take note of the voltage data on the nameplate!*

Observe the national regulations for electrical installations!

For devices used in hazardous areas, additional safety notes apply; please refer to the Ex documentation.

*Observe without fail the local occupational health and safety regulations.
Any work done on the electrical components of the measuring device may only be carried out by properly trained specialists.*

*Look at the device nameplate to ensure that the device is delivered according to your order.
Check for the correct supply voltage printed on the nameplate.*

4.2 Grounding

The device must be grounded in accordance with regulations in order to protect personnel against electric shocks.

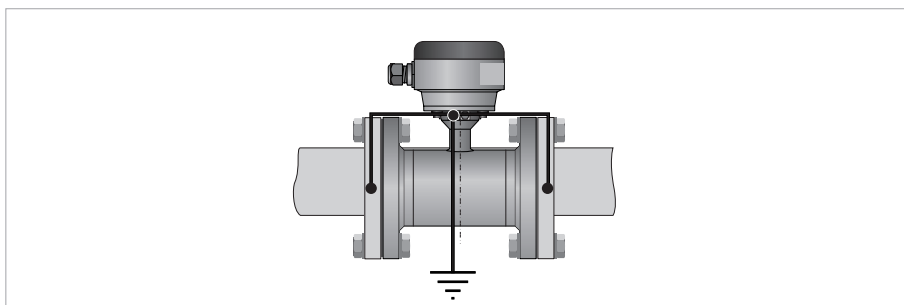

Figure 4-1: Grounding

Metal pipelines, not internally coated. Grounding without grounding rings.

Grounding can be omitted with Virtual reference (option on IFC 300 converter). For detailed information refer to Virtual reference for IFC 300 (C, W and F version) on page 27.

4.3 Virtual reference for IFC 300 (C, W and F version)

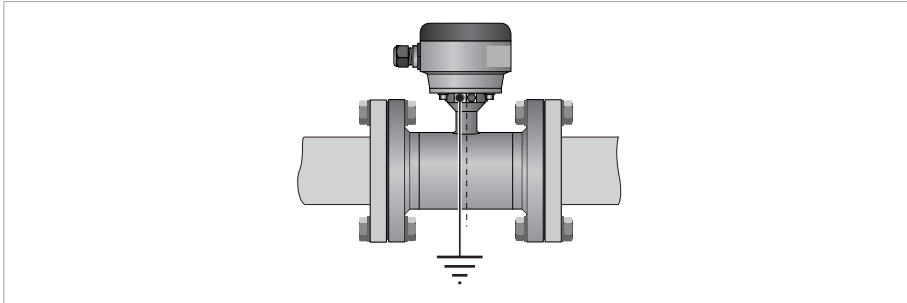

Figure 4-2: Virtual reference

Minimum requirements:

- Size: \geq DN10 / 3/8"
- Electrical conductivity: \geq 200 μ S/cm
- Signal cable: max. 50 m / 164 ft, type DS

4.4 Connection diagrams

For the connection diagrams the documentation of the applicable signal converter.

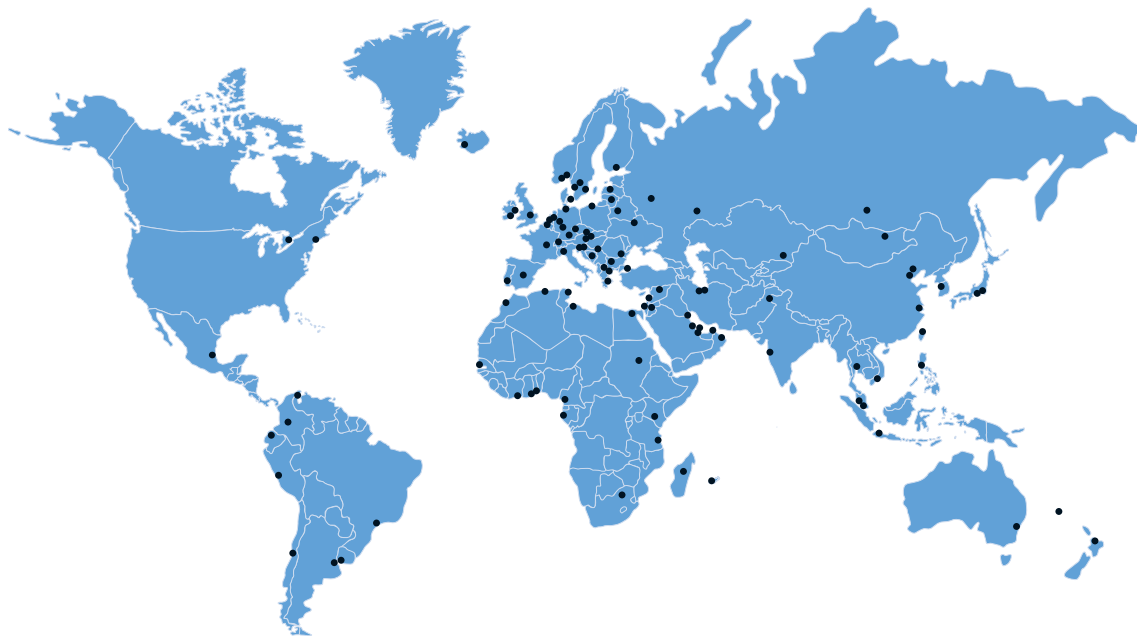

KROHNE – Process instrumentation and measurement solutions

- Flow
- Level
- Temperature
- Pressure
- Process Analysis
- Services

Head Office KROHNE Messtechnik GmbH
Ludwig-Krohne-Str. 5
47058 Duisburg (Germany)
Tel.: +49 203 301 0
Fax: +49 203 301 10389
info@krohne.com

The current list of all KROHNE contacts and addresses can be found at:
www.krohne.com

KROHNE