

0650-722-01-00010-010

Original

Installation and Maintenance Manual

EM 710 Shallow Water Multibeam Echo Sounder

Alaska Region Research Vessel (ARRV)



R/V Sikuliaq

Marinette Marine Corporation
Fincantieri Marine Group
1600 Ely Street
Marinette, WI 54143

15 April 2012

RECORD OF CHANGES

REVISION	DATE	DESCRIPTION OF CHANGE	BY
-	4-15-12	INITIAL ISSUE	JKR

FOREWORD

THIS MANUAL IS INTENDED TO CLEARLY AND ACCURATELY REFLECT THE ACTUAL CONFIGURATION OF THE INSTALLED EQUIPMENT AND PROVIDE THE USER WITH THE NECESSARY INSTRUCTIONS TO SUCCESSFULLY OPERATE, MAINTAIN, AND TROUBLESHOOT ASSOCIATED EQUIPMENTS. THE MANUAL IS CONSTRUCTED AS FOLLOWS:

- **EM 710 MULTIBEAM ECHO SOUNDER INSTALLATION MANUAL**
 - **GENERAL INFORMATION**
 - **TECHNICAL SPECIFICATIONS**
 - **TRANSDUCER ARRAYS**
 - **INSTALLATION EXAMPLES**
 - **SYSTEM UNITS**
 - **CABLE LAYOUT**
 - **ALIGNMENT**
 - **SYSTEM TEST**
 - **INSTALLATION DRAWINGS**
- **EM 710 MULTIBEAM ECHO SOUNDER MAINTENANCE MANUAL**
 - **GENERAL INFORMATION**
 - **TECHNICAL SPECIFICATIONS**
 - **CABLE LAYOUT**
 - **OPERATOR STATION**
 - **TRANSCIVER UNIT**
 - **TROUBLESHOOTING**
 - **REPLACEMENT PROCEDURES**
 - **SPARE PARTS**
 - **MAINTENANCE PROGRAM**
 - **INSTALLATION DRAWINGS**

CONFIGURATION

THE FOLLOWING PIECES OF EQUIPMENT ARE THE MAJOR PARTS OF THIS SYSTEM

- **KONGSBERG EM 710 MULTIBEAM ECHO SOUNDER**

Installation Manual



KONGSBERG

EM 710

Multibeam echo sounder

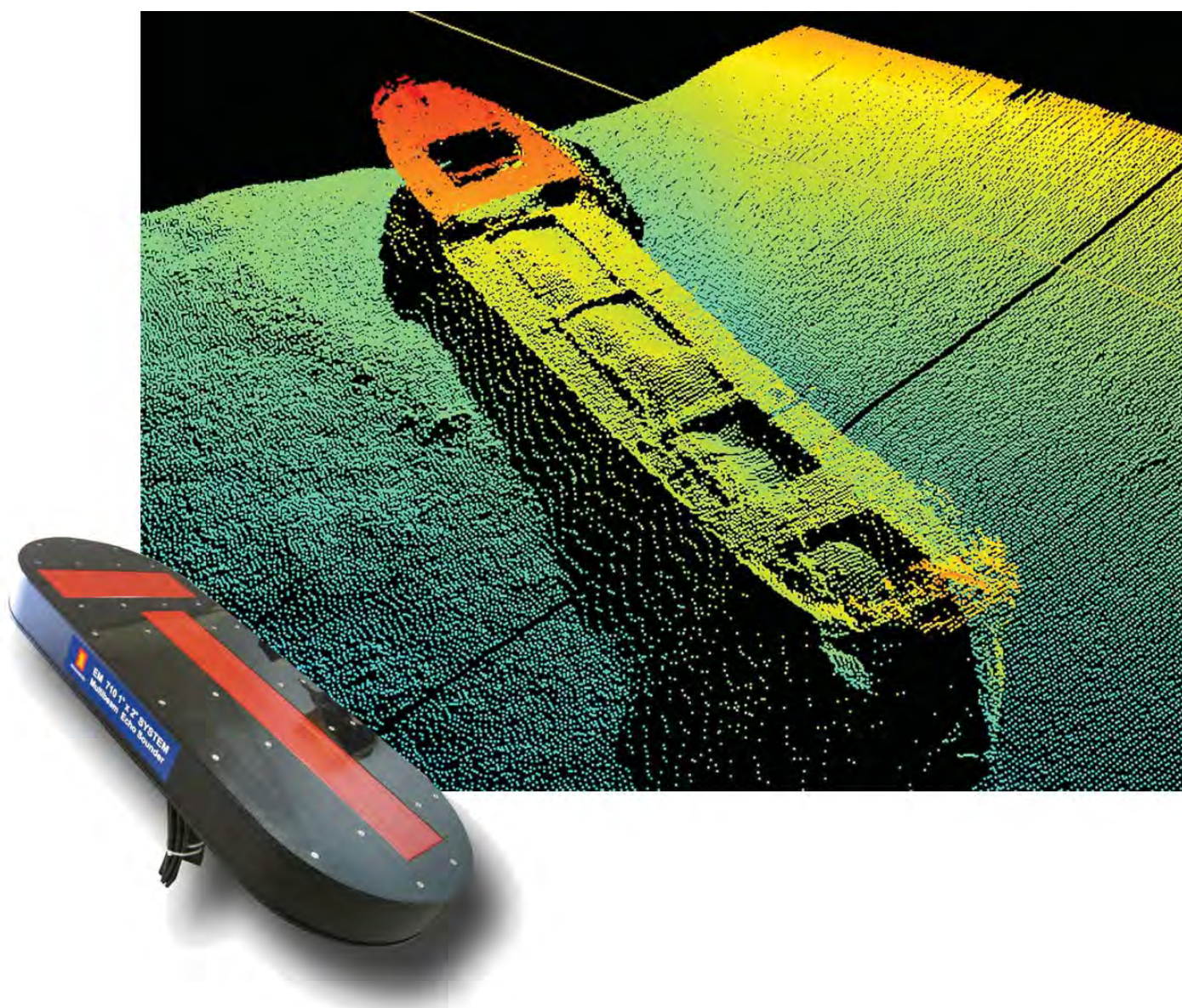

Kongsberg EM 710 Multibeam echo sounder

Installation Manual

Kongsberg Maritime

Document history

Document number: 164851		
Rev. A	January 2006	First version.
Rev. B	11.08.2006	
Rev. C	June 2009	

Note

The information contained in this document remains the sole property of Kongsberg Maritime AS. No part of this document may be copied or reproduced in any form or by any means, and the information contained within it is not to be communicated to a third party, without the prior written consent of Kongsberg Maritime AS.

Kongsberg Maritime AS endeavours to ensure that all information in this document is correct and fairly stated, but does not accept liability for any errors or omissions.

Warning

The equipment to which this manual applies must only be used for the purpose for which it was designed. Improper use or maintenance may cause damage to the equipment and/or injury to personnel. The user must be familiar with the contents of the appropriate manuals before attempting to operate or work on the equipment.

Kongsberg Maritime disclaims any responsibility for damage or injury caused by improper installation, use or maintenance of the equipment.

Comments

To assist us in making improvements to the product and to this manual, we welcome comments and constructive criticism.

e-mail: km.documentation@kongsberg.com

Kongsberg Maritime AS

Strandpromenaden 50
P.O.Box 111
N-3191 Horten,
Norway

Telephone: +47 33 02 38 00
Telefax: +47 33 04 47 53
www.kongsberg.com
subsea@kongsberg.com



KONGSBERG

Table of contents

1	ABOUT THIS MANUAL	7
2	EM 710.....	8
2.1	System overview	8
2.2	System characteristics	11
2.3	Scope of supply	12
2.4	Supply conditions	14
2.4.1	Equipment responsibility	14
2.4.2	Project management.....	14
2.4.3	Installation, supervision and commissioning	15
2.5	Warranty	16
2.6	Installation requirements	16
2.6.1	Power supply.....	16
2.6.2	Environmental requirements	17
2.6.3	Noise sources	17
2.6.4	Dry docking	17
2.6.5	Wiring.....	17
2.7	General safety rules	18
3	TECHNICAL SPECIFICATIONS	19
3.1	Interfaces	19
3.2	Physical specifications.....	21
3.3	Power requirements.....	22
3.4	Environmental and EMC specifications	23
3.5	System performance data	23
3.6	External synchronisation and remote on/off.....	24
3.6.1	Clock sync 1 PPS.....	25
4	TRANSDUCER ARRAYS	26
4.1	Installation principles	26
4.1.1	Basic description	26
4.1.2	Installation philosophy	27
4.2	Installation steps	27
4.3	Locating the transducer array	31
4.3.1	The boundary water layer	31
4.3.2	Propeller noise.....	31
4.3.3	Noise from protruding objects on the hull.....	32
4.3.4	Summary.....	32
4.4	Installing the steel conduits	36
4.4.1	Logistics and references	37
4.4.2	Procedure.....	37

4.5	Installing the mounting frames.....	38
4.5.1	Logistics and references	38
4.5.2	Procedures	38
4.5.3	Installation accuracy of frames	39
4.6	Installing the transducer modules.....	39
4.6.1	Logistics and references	40
4.6.2	Procedure.....	40
5	INSTALLATION EXAMPLES.....	43
5.1	Transducer blister	43
5.1.1	Logistics and references	43
5.2	Gondola	45
5.2.1	Logistics and references	45
5.3	Flush mount.....	46
5.4	Fairing	47
5.5	Steel box	47
6	SYSTEM UNITS.....	48
6.1	Operator station	48
6.2	Transceiver Unit	48
6.2.1	Location.....	49
6.2.2	General information	49
6.2.3	Logistics	50
6.2.4	Procedure.....	50
6.2.5	Surface preservation.....	54
6.3	Remote Control Junction Box	54
6.3.1	Location.....	54
6.3.2	General information	54
6.3.3	Logistics	54
7	CABLE LAYOUT.....	56
7.1	System cabling	57
7.2	Operator Station cables	58
7.3	Transceiver Unit cables	60
7.3.1	Transceiver Unit – front view	60
7.3.2	Transceiver Unit – rear view.....	74
7.3.3	Transceiver Unit – Cable configuration	83
7.3.4	TRU compact – 2 x 2 degree system	87
7.4	Transducer cables	89
7.4.1	Transmit array cable markings	89
7.4.2	Receive array cable markings	92
7.5	Cable specifications	92
7.6	Basic cabling requirements	93
8	ALIGNMENT	96

8.1	Summary	97
8.2	Vessel coordinate system.....	98
8.3	Sensor location and alignment	99
8.3.1	Motion sensor.....	99
8.3.2	Heading sensor	100
8.3.3	Positioning system	100
8.3.4	Water line.....	100
8.4	Transducer Measurements	101
8.4.1	Transducer heading.....	101
8.4.2	Transducer roll and pitch.....	101
8.4.3	Transducer position.....	102
8.4.4	System calibration after final alignment	102
8.5	Calibration of system.....	102
9	SYSTEM TEST	103
9.1	Visual inspection of units	104
9.1.1	Scope.....	104
9.1.2	Operator Unit	104
9.1.3	Transceiver Unit	105
9.2	Electrical checks.....	106
9.2.1	Scope.....	106
9.2.2	Cabling	106
9.2.3	Operational voltages	107
9.3	Final installation checks	107
10	INSTALLATION DRAWINGS.....	109
10.1	Installation Drawings	110
10.1.1	0.5° mounting frame assembly TX module	110
10.1.2	1° mounting frame assembly RX module.....	112
10.1.3	2° mounting frame assembly TX/RX module.....	114
10.1.4	0.5 x 1° gondola.....	116
10.1.5	Transducer TX1 Outline dimensions	118
10.1.6	Transducer TX2 Outline dimensions	120
10.1.7	Transducer RX1 Outline dimensions	122
10.1.8	Transducer RX2 Outline dimensions	124
10.1.9	HWS Operator Station Outline dimensions.....	126
10.1.10	Transceiver Unit Outline dimensions.....	127
10.1.11	Transceiver Unit 2 x 2 degree system – Outline dimensions.....	129
10.1.12	Transceiver Unit mounting bracket	131
10.1.13	Junction Box – outline dimensions.....	132
10.1.14	Transceiver Unit cable clamp.....	133
10.2	Cable Drawings	134
10.2.1	Generic RS-232 Serial line	134
10.2.2	Generic coax cable.....	135

10.2.3	Sound speed probe interface	136
10.2.4	RS-232 or RS-422/485 serial line	137
10.2.5	Trigger in/out (not used).....	138
10.2.6	Internal control signals	139
10.2.7	Remote control and external trig	140
10.2.8	Standard AC power cable	141
10.2.9	Ethernet cable with RJ45	142
10.2.10	VGA/SVGA Display cable.....	143
10.2.11	USB cable	144
10.2.12	Keyboard cable.....	145
10.2.13	Mouse cable	146
10.2.14	Parallel printer	147
10.2.15	RX/TX transducer cables.....	148

1 ABOUT THIS MANUAL

The purpose of this manual

The purpose of this installation manual is to provide the descriptions and procedures required to install the Kongsberg EM 710 Multibeam echo sounder system units, and to perform the necessary cabling between the individual system units, and between the system and peripheral systems, sensors and devices.

Note

Detailed vessel specific mechanical drawings for the installation must be provided by the customer, or any shipyard contracted to perform the installation. Kongsberg Maritime AS may, on special order, supply these drawings. Drawings must be approved by the appropriate vessel certification authority prior to installation of the system.

The installation instructions given in this document must be adhered to. Failure to do so may render the guarantee void.

No special tools are generally required to perform installation, removal and replacement of modules and parts. When special tools are required, these are listed in the installation procedure.

2 EM 710

Topics

- *System overview* on page 8
- *System characteristics* on page 11
- *Scope of supply* on page 12
- *Supply conditions* on page 14
- *Installation requirements* on page 16
- *Warranty* on page 16
- *General safety rules* on page 18

2.1 System overview

Key facts

The EM 710 multibeam echo sounder is a high to very high resolution seabed mapping system capable of meeting all relevant survey standards. The system configuration can be tailored to the user requirements, allowing for choice of beamwidths as well as transmission modes. The minimum acquisition depth is from less than 3 m below its transducers, and the maximum acquisition depth is up to 2000 m.

Acrosstrack coverage (swath width) is up to 5.5 times water depth to a maximum of more than 2000 m. The sounding density is very high, allowing even the very demanding LINZ special order survey specification for object detection to be met in full.

There are three basic versions of the EM 710:

- EM 710 - Full performance version.
- EM 710S - CW pulse forms only.
- EM 710RD - Short CW pulse only.

The reduced performance versions EM 710S and EM 710RD are upgradable to full performance.

Innovative acoustic principles

The EM 710 operates at sonar frequencies in the 70 to 100 kHz range. The transmit fan is divided into three sectors to maximize range capability but also to suppress interference from multiples of strong bottom echoes. The sectors are transmitted sequentially within each ping, and uses distinct frequencies or waveforms.

Both CW pulses of different lengths and even longer, compressible waveforms (chirps) are utilized. The alongtrack beamwidth depends upon the chosen transducer configuration with 0.5, 1 and 2 degrees available as standard. Focusing is applied individually to each transmit sector to retain the angular

resolution inside the near field. A ping rate of up to 25 per second is possible. The transmit fan is electronically stabilized for roll, pitch and yaw.

The EM 710 has a receive beamwidth of either 1 or 2 degrees depending on the chosen receive transducer. The number of beams is 256 or 128 respectively, with dynamic focusing employed in the near field.

A high density beam processing mode provides up to 400 or 200 soundings per swath by using a limited range window for the detections, which in practice is equivalent to synthetically sharpening the beamwidth.

The system will be able to generate two separate alongtrack swaths per ping. The system produces up to 800 (with 1 degree receive transducer) soundings per ping in this mode.

The beamspace may be set to be either equiangular or equidistant. The receive beams are electronically roll stabilized. This can be used to increase the resolution beyond what is achievable in normal operation. In high density mode, the size of each acoustic footprint is reduced to fit the higher sounding density. The coverage may be limited by the operator either in angle or in swath width without reducing the number of beams. A combination of phase and amplitude bottom detection algorithm is used, in order to provide soundings with the best possible accuracy.

Acoustical seabed imaging

Integrated seabed acoustical imaging capability is included as standard. Software to use this data for automatic seabed classification is available.

Water column display

A real time display window for water column backscatter is available. Logging of water column data and of raw stage data (before beamforming) is a system option.

Choice of operator software

The EM 710 is delivered as a complete stand-alone seabed mapping system. The Operator Station, a high-performance PC work station, includes the necessary operator controls for setting up and running the system, data logging and system testing. The Seafloor Information System (SIS) by Kongsberg Maritime also includes an extensive set of graphical displays for data quality control, as well as system calibration and other tools which are required. SIS supports on-line real-time data cleaning to improve the overall survey efficiency.

Post-processing software for the EM 710 is available from both Kongsberg Maritime and third-party suppliers.

System drawing

Figure 1 EM 710 system units and interfaces

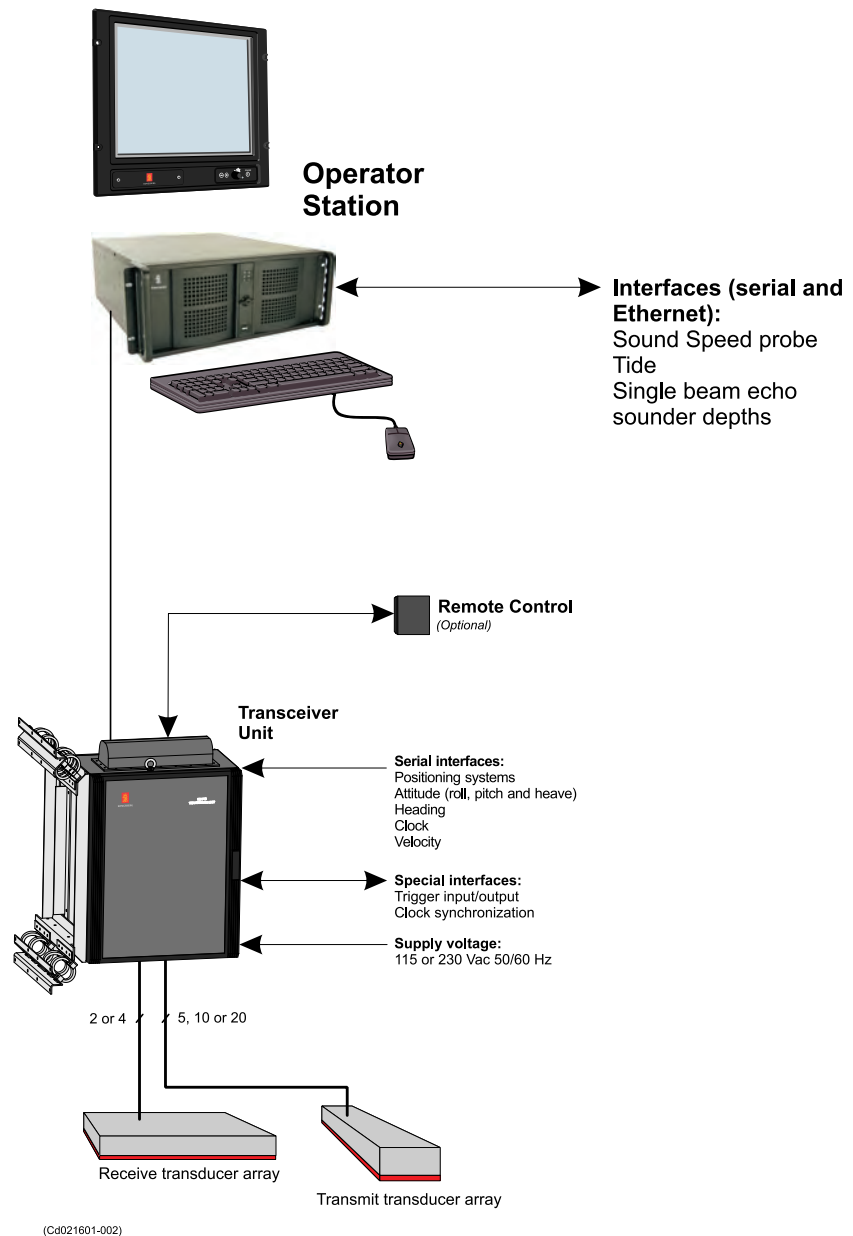

System configuration with desktop operator station, transceiver unit and transducer arrays.

2.2 System characteristics

Main units

The basic EM 710 multibeam echo sounder consists four units

- Transmit Transducer
- Receive Transducer
- Transceiver Unit
- Operator Station

A complete mapping system will in addition include a vessel motion sensor, heading sensor, sound velocity sensor(s) and a positioning system.

Transducers

The EM 710 transducers are fully water tight units intended for many years of trouble-free operation in rough seas. The transmit and receive transducers both have a width of 224 mm and a height of 118 mm. Their length depends upon the chosen beamwidth, either 970 mm for a 1 degree unit or 490 mm for a 2 degrees unit. The weights are respectively 35 and 18 kg (excluding cables).

The weight of a 0.5° x 1° system are 70 and 18 kg (excluding cables).

The transducers have a maximum depth rating of 250 m.

A transmit beamwidth of 0.5 degree is achieved by mounting two 970 mm transmit transducers together alongship. Such a beamwidth reduction is not possible with the receive transducer.

The transducers are supplied as standard with 15 m long underwater cables terminated with a surface connector directly pluggable into the Transceiver Unit. On special order underwater connectors or longer cables may be supplied. Five, ten or twenty cables are used on the transmit transducer, two or four on the receive transducer, in accordance with the transducer length.

Transceiver Unit

The EM 710 Transceiver Unit contains all transmit and receive electronics, and the Processing Unit which performs the beamforming, bottom detection, and motion and sound speed corrections. It contains all interfaces for time-critical external sensors such as vessel attitude (roll, pitch, heading and heave), vessel position and external clock. More than one sensor of each type may be connected simultaneously, with one in use but all logged.

The Transceiver Unit comprises two 19" sub-racks contained in a cabinet designed for bulkhead or deck mounting.

For the 2° x 2° system, the TRU are compressed in one 19" sub-rack.

The number of circuit boards will depend upon the chosen transducer configuration. Twisted pair Ethernet is used for data communication with the Operator Station.

Operator Station

The Operator Station of the EM 710 is the HWS high performance dual-processor PC workstation. The operator software is the Seafloor Information System (SIS). The HWS dual bootable to either Linux® or Windows XP®.

SIS, as a minimum, allows setting the EM 710 installation and runtime parameters, data logging and running self-test on the system without restrictions.

The SIS software also includes functionality for survey planning, 2D and 3D geographical display of the survey results, seabed image and water column displays, plus real-time data cleaning algorithms.

Alternatively, third-party software solutions can be used for the operator interface and real-time processing.

The HWS is normally supplied with a 19" industrialized LCD monitor with a resolution of 1280 x 1024 pixels. Support for a second monitor is included. A spill-proof US keyboard and a standard optical mouse is normally supplied, but optionally a small IP 65 rated keyboard with integrated track stick can be delivered.

2.3 Scope of supply

Standard system

A basic EM 710 multibeam echo sounder delivery includes:

- 1 Operator Station HWS with 19" LCD monitor
- 2 Transceiver Unit configured according to chosen model
- 3 Transducers in accordance to chosen model
 - Transmit transducer (includes mounting frame)
 - Receive transducer
 - Necessary transducer cables (15 m length)
- 4 Signal and control cables
 - Ethernet cable between Transceiver Unit and Operator Station (4.5 m length)
- 5 All system software
- 6 Technical manuals covering system installation, operation and maintenance

Options

System options available include:

- Mounting arrangement for over-the-side mounting of 2 by 2 degrees model transducers which may include integrated motion sensor, heading sensor and positioning sensor
- Remote control unit for Transceiver Unit
- Non-standard cable lengths or connectors
- Helmsman Display and/or additional monitors
- Various software options
- Removable disks
- IP65 integrated keyboard and pointing device
- Spare parts

System integration

The EM 710 system as presented in this product description is prepared for integration with other sensors to form a complete seabed mapping and inspection system. Kongsberg Maritime can supply the EM 710 either as a subsystem for integration by the user or other parties, or we can offer complete system solutions tailored to the user's need.

Dual frequency system solutions can be formed by combining the EM 710 with a lower frequency multibeam echo sounder such as the EM 122 and EM 302.

Additionally Kongsberg Maritime may deliver the EM 710 as part of a complete survey system. This may include integration with single beam echo sounders and/or other multibeam echo sounders for seamless coverage of any depth range.

Services

Kongsberg Maritime AS may assist with the required engineering services for installation. These services may include:

- Recommending the best location of the transducer arrays
- Installation sketches to fit the specific vessel
- Assistance during the installation
- Testing
- Training

Assistance from Kongsberg Maritime AS must be ordered separately, and are charged according to the contract.

2.4 Supply conditions

2.4.1 Equipment responsibility

Upon receipt of the equipment the system owner or installation shipyard automatically becomes fully responsible for the equipment, unless otherwise stated in the contract. This responsibility covers the storage period before installation, the actual installation, commissioning, and the period between the completion of the commissioning and the acceptance of the equipment by the end user (normally the owner of the vessel or platform into which the equipment is to be installed).

During the installation period the equipment must be covered in such a way that it is protected from dust, paint spray/splashes and welding/cutting sparks. Precautions must be taken to ensure that no part of the equipment is used as a work platform, or for any other purpose for which it was not designed.

Any damage incurred during the installation period, even with a Kongsberg Maritime AS representative present, is the installation shipyard's responsibility unless it can be proven that the damage was due to production or material defects in the equipment delivered by Kongsberg Maritime AS, or irresponsibility by Kongsberg Maritime AS personnel.

2.4.2 Project management

Project manager

Kongsberg Maritime AS will normally appoint a dedicated project manager for the delivery project. The manager will follow up the installation and delivery, and will be the installation shipyard's and end user's point of contact.

Installation performed by Kongsberg Maritime

Kongsberg Maritime AS will assist during the installation if specified in the contract or requested by the installation shipyard or customer. Before any installation work by Kongsberg Maritime AS can begin, all cables (at least those which are in any way connected with the system) must be run and connected to their respective terminations. These cables together with the transducer installation will then be checked by the Kongsberg Maritime AS engineers before they are used.

Depending upon the availability of electrical power either from the generators on board or from ashore, the equipment related to the system, and the various parts of the system will be tested during the Setting to Work (STW) period. This requires that interfaces to equipment delivered by other subcontractors are ready for integration testing.

Delays may occur if any of the equipment related to the system is not available for Kongsberg Maritime AS for testing. During sea trials, the vessel must be at Kongsberg Maritime's disposal when required, even though we cannot be held responsible for expenses relating to the running costs of the vessel.

After completion of the commissioning, the equipment should be officially handed over to the end user and the appropriate documents signed in accordance with the contract. All defects or deviations from the contract must be specified in detail in these documents. It should be noted that if such defects or deviations are not specified, they cannot be used by any of the parties concerned as valid reason for not signing the documents.

2.4.3 Installation, supervision and commissioning

Electrical and mechanical installation

The installation shipyard is normally responsible for the installation of the entire system. In addition, the shipyard is responsible for providing and connecting all cables other than special cables supplied with the equipment. The actual installation and cable laying must comply with the vessel's classification rules and the recommendations given in this manual.

Base frames may be required for some units. If so, these must be manufactured in accordance with the drawings provided in the applicable sections in this manual.

During the installation period, the equipment must be covered in such a way that it is protected from dust, paint spray/splashes and welding/cutting sparks. Precautions must be taken to ensure that no part of the equipment is used as a work platform, or for any other purpose for which it was not designed.

Note

Any damage incurred during the installation period, even with a Kongsberg Maritime AS representative present, is the installation shipyard's responsibility unless it can be proven that the damage was due to production or material defects in the equipment delivered by Kongsberg Maritime AS, or irresponsibility by Kongsberg Maritime AS personnel.

Pre-commissioning and acceptance tests

Pre-commissioning and acceptance tests are conducted by Kongsberg Maritime AS personnel.

Installation tests

The Kongsberg Maritime installation period (after shipyard installation) is normally divided into three consecutive phases

- The initial start-up and dock-side testing period. This period is normally known as Setting-to-Work (STW).
- Dock-side commissioning under operational conditions. This commissioning period is normally ended with a Harbour Acceptance Test (HAT).
- Sea Acceptance Test (SAT) with final commissioning under operational conditions at sea.

The extent of the tests is normally defined in the contract.

If required during a contractual test period, the shipyard must provide assistance necessary for the rapid and efficient completion of the work even when the work is to be performed outside normal working hours. This requirement includes assistance from subcontractors when applicable. Excessive waiting time resulting from delays caused by the shipyard will be charged to the shipyard.

HAT and SAT are performed according to Kongsberg Maritime test procedures

2.5 Warranty

The warranty on the scope of supply is 24 months from the date when the equipment is sent from the factory. Warranty does not cover damage or defects coming from improper storing of the equipment (i.e. cable damage by temperature oscillation, rusty components, physical damage etc.)

2.6 Installation requirements

2.6.1 Power supply

The supply voltage to the equipment is to be kept within the specifications given in the chapter *Power requirements* on page 22.

Kongsberg Maritime strongly recommends that the EM 710 Operator Station is powered through an Uninterruptedly Power Supply (UPS). The UPS must be large enough to allow minimum 10 minutes operation. The system can then be switched off in a controlled manner in case of power failures.

2.6.2 Environmental requirements

Vibrations

If the vibration velocity amplitude at the base of the installed equipment is expected to exceed 1g in the range 5–50 Hz, constantly during operational life, special precautions are to be taken.

Consult the applicable manufacturer's documentation for shock and vibration damping of the EM 710 Operator Station and peripherals.

For more information about temperature and environment, see *Environmental and EMC specifications* on page 23

Temperature and humidity

All equipment, unless otherwise specified, must be protected from temperature extremes and excessive humidity.

2.6.3 Noise sources

The vessel's hull, rudder(s) and propeller(s) should be thoroughly inspected in dry dock prior to installation. Roughness below the water-line, deformities in the shell plating and protruding obstacles can create acoustical noise. These sources of turbulence must be smoothed or removed as best as possible. It is especially important that the propeller(s) is not pitted or damaged.

2.6.4 Dry docking

The Transducer installation must be done when the vessel is in dry dock. Make sure there is sufficient working space under the hull for this installation work.

Note

The location of the gondola and/or protection blister must be noted on the vessel's docking plan for future reference.

2.6.5 Wiring

All cables between the bridge, the various operation- and equipment rooms, must be supported and protected along their entire length using conduits or cable trays. Note that the cables must not be installed in the vicinity of high-power supplies and cables, antenna cables or other possible sources of interference.

2.7 General safety rules

The system operates on 115 and/or 230 Vac, 50/60 Hz with a switch in the Transceiver Unit.

WARNING

This voltage can be lethal.

The following safety precautions must be followed at all times during installation and maintenance work:

- Always switch off all power before installation or maintenance. Use the main circuit breaker, and label the breaker with a warning sign that informs others that maintenance or installation work is being carried out on the system.
- Read and understand the first aid instructions for electric shock.
- For safety reasons during troubleshooting on the equipment with power ON, two persons should always be present.
- Whenever maintenance is carried out, it is essential that a first aid kit is available, and that the maintenance personnel are familiar with the first aid instructions for electrical shock.
- The various parts of the system are heavy. Make sure that the appropriate tools and certified lifting equipment are available, and that the personnel are trained in installation and maintenance work.

3 TECHNICAL SPECIFICATIONS

Note

Kongsberg Maritime AS is engaged in continuous development of its products and reserves the right to alter specifications without prior notice.

Topics

- *Interfaces* on page 19
- *Physical specifications* on page 21
- *Power requirements* on page 22
- *Environmental and EMC specifications* on page 23
- *System performance data* on page 23
- *External synchronisation and remote on/off* on page 24

3.1 Interfaces

These interfaces are found on the Transceiver Unit and the Operator Station:

- Serial lines with operator adjustable baud rate, parity, data length and stop bit length for:
 - Motion sensor (roll, pitch, heave and optionally heading) in format supported by sensors from the main suppliers like Applanix , iXSEA, Coda, Kongsberg Maritime
 - Heading NMEA 0183 HDT, SKR82/LR60 or EM attitude format or Sperry Mk39 format
 - Positions in either Simrad 90, NMEA 0183 GGA or GGC format
 - External clock in NMEA 0183 ZDA format / Trimble UTC
 - Sound speed at transducer
 - Sea level height (tide)
 - Single beam echo sounder depths
 - Output of depth straight down in NMEA 0183 DPT format
- Interface for 1PPS (pulse per second) clock synchronisation signal
- SATA and Firewire interface for external data storage devices
- USB 2.0 interfaces for data storage, printing or plotting
- Parallel interface for Postscript colour graphics printer/plotter
- Ethernet interface for velocity input needed for Doppler compensation in chirp mode.

- Gigabit and Megabit Ethernet interface for input of sound speed profile, tide and echo sounder depths, and output of all data normally logged to disk.

3.2 Physical specifications

Transducer – 2 degrees

- **Length:** 490 mm
- **Width:** 224 mm
- **Height:** 118 mm
- **Weight:** 18 kg (nominal without cables)

Transducer – 1 degree

- **Length:** 970 mm
- **Width:** 224 mm
- **Height:** 118 mm
- **Weight:** 35 kg (nominal without cables)

Transducer – 0.5 degree (two 1 degree modules)

- **Length:** 1940 mm
- **Width:** 224 mm
- **Height:** 118 mm
- **Weight:** 70 kg (nominal without cables and mounting frame)

Transceiver Unit (version for bulkhead mounting)

- **Height:** 841 mm
- **Width:** 540 mm
- **Depth:** 750 mm (nominal including shock absorbers)
- **Weight:**
 - 106 kg (2 by 2 degrees)
 - 111 kg (1 by 2 degrees)
 - 116 kg (1 by 1 degree)
 - 127 kg (0.5 by 1 degree)

Note

A smaller Transceiver Unit is normally used for the 2 by 2 degrees model. (See below)

TRU compact – 2 x 2 degree system on page 87

Transceiver Unit – 2 x 2 degree system (version for bulkhead mounting)

- **Height:** 573 mm
- **Width:** 540 mm
- **Depth:** 750 mm (nominal including shock absorbers)
- **Weight:** 83 kg

Operator Station

- **Height:** 127 mm
- **Width:** 427 mm (excluding rack fixing brackets)
- **Depth:** 480 mm (excluding handles and connectors)
- **Weight:** Approximately 20 kg

19" inch LCD monitor

- **Height:** 444 mm (excluding mounting brackets)
- **Width:** 483 mm (excluding mounting brackets)
- **Depth:** 68 mm (excluding mounting brackets)
- **Weight:** 12 kg (approximately with bracket)

3.3 Power requirements

Operational voltage and frequency

- AC voltage: 115 (60 Hz) or 230 (50 Hz) Vac
Voltage $\pm 10\%$
Frequency $\pm 5\%$

Acceptable transients

- Short time (max. 2 sec) : $\pm 20\%$, 42 – 69 Hz
- Spikes (max. 50 μ s) : < 1000 V

Transceiver Unit

- 0.5° x 1°: < 800W
- 1° x 1°: < 600W
- 1° x 2°: < 500W
- 2° x 2°: < 400W
- The single phase supply must be protected with 16A (230 Vac supply) slow-blow fuses.
- **Operator Station:** < 250 W
- **LCD monitor:** < 60 W (max)
- **Remote Control:** None

Note _____

*For 115 Vac operation, please contact
km.hydrographic.support@kongsberg.com*

Power interrupts

Menu settings, all parameters and the sound speed profile are stored on the Operator Station's harddisk during operation, so operation can continue after power interruption. However, the file system may be damaged, so the use of an uninterruptable power supply (UPS) is highly recommended.

3.4 Environmental and EMC specifications

The system meets all requirements of the IACS E10 specification.

The Transceiver Unit meet the additional stronger requirements of the IEC 60945 specification.

The Operator Station and the LCD monitor are both IP22 rated. The Transceiver Unit is IP54 rated.

Environment

- Operating temperature, sonar room: -5 to 50° C for TRU and TD
- Operating temperature, operating room: +5 to 50° C for HWS
- Storage temperature: -30 to +70° C
- Humidity: 95% RH at 55°C , non-condensing

Humidity requirements will depend on customer requirements. Normal specification is up to 80% non-condensing.

Note

To extend the lifetime of the equipment, the sonar room should be equipped with sufficient ventilation and the temperature should not be too high (i.e. not > 30°C) for long periods of time.

Vibration

- 5 – 150 Hz, 1.23g rms
2 hours duration

Shock

- Cabinets w/shock absorbers: 15g half period sine pulse
- Duration: 11 ms

3.5 System performance data

- **Frequency range:** 70 to 100 kHz
- **Maximum ping rate:** 30 Hz

- **Number of beams and soundings for each ping:**
 - 1 x 2 and 2 x 2 degrees: 128 beams with 200 soundings in High Density mode per swath
 - 0.5 x 1 and 1 x 1 degree: 256 beams with 400 soundings in High Density mode per swath
 - With Dual swath the number of beams and soundings are doubled
- **Beamwidths:** 0.5 x 1, 1 x 2, 1 x 2 or 2 x 2 degrees
- **Beam spacing:** Equidistant, Equiangle, High Density
- **Coverage sector:** Up to 140 degrees
- **Transmit beam steering:** Stabilized for roll, pitch and yaw
- **Receive beam steering:** Stabilized for roll
- **Depth range from transducers:** 3 to approximately 2.000 metres
- **Depth resolution:** 1 cm
- **Pulse lengths:** 0.15, 0.5 and 2 ms CW and up to 120 ms FM
- **Range sampling rate:** 14 kHz (5 cm) at data output

3.6 External synchronisation and remote on/off

The RS 232 serial line type RTS and CTS signals are used for external synchronisation. In addition a trig out signal is issued by the TRU.

The signals are available on the plug marked remote on the TXP RIO.

Table 1

Signal	Levels	Function	TRU remote plug
CTS (TRU input)	H=high= +3 to +15 V L=low = -3 to -15 V	H: Ping command to TRU L: Wait	Pin 8
RTS (TRU output)	H=high= +3 to +15 V L=low = -3 to -15 V	H: TRU is ready for a new ping L: TRU is busy	Pin 7
CTS/RTS gnd			Pin 6
Trig out (TRU output)	TTL Level	H: TX is off L: TX is active	Pin 1
Trig gnd			Pin 2

For cable details, see *Remote control and external trig* on page 140

Figure 2 Typical sequence

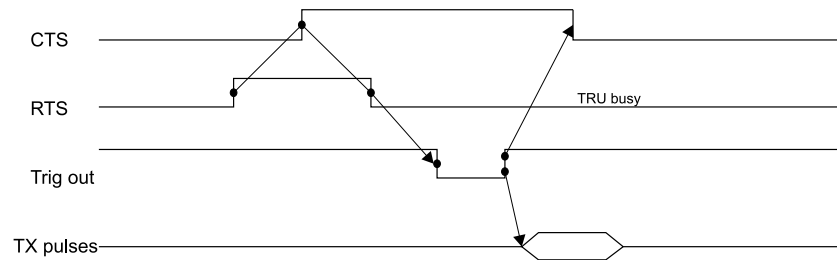

(cd021101-005)

When the TRU is ready for a new ping, RTS is set to H. When the external device is ready for a new ping, CTS shall be changed to H. The CTS must be high for minimum 100 microseconds. The TRU will then change RTS to L (busy), issue a Trig out signal (will be low for 1 millisecond) to indicate the start of the transmit pulses, and then transmit the TX pulses. After the Trig out is received, the external device should turn CTS back to L. When the receive period is finished and the TRU is ready for a new ping, the RTS will be changed to H, and the TRU will wait for a new trigger (a high level on CTS). If CTS is H all the time, or if external sync in the installation menu is switched off, the TRU will ping at its maximum rate.

Remote on/off

The TRU on/off function can be remotely controlled. The TRU is turned on by connecting pin 4 and 5 in the TRU remote plug together.

Trigger in/out (not used) on page 138

3.6.1 Clock sync 1 PPS

The 1 PPS (on pulse per second) signal is connected to the coax connector on the BSP RIO board. The BSP RIO is equipped with an optocoupler at this input. The input series resistor is tuned for a TTL signal (Low level < 0.6 V, High level > 3.2 V). The falling edge of the signal is used by the TRU to synchronize the internal clock. The 1 PPS signal must be minimum 1 microsecond long.

4 TRANSDUCER ARRAYS

This chapter describes the installation of the EM 710 Transmit (TX) and Receive (RX) Transducer Arrays.

Drawings showing the installation principles and the physical dimensions are included in the text. Other drawings are included in the Drawing File.

Topics

- *Installation principles* on page 26
- *Installation steps* on page 27
- *Locating the transducer array* on page 31
- *Installing the steel conduits* on page 36
- *Installing the mounting frames* on page 38
- *Installing the transducer modules* on page 39

4.1 Installation principles

4.1.1 Basic description

The EM 710 uses separate transducer arrays for transmitting and receiving sound pulses.

The transducers may be fixed to the hull with bolts from the front, either directly on or recessed into the hull, or within sea chests.

The two transducer arrays are normally mounted as “T” or “L”-configurations, or a similar variant under the vessel’s hull (Mills Cross configuration).

The transmit transducer array should be approximately aligned parallel to the vessel’s keel. The receiver transducer array should be approximately aligned 90° on the keel. Both transducers should be horizontal, approximately on a plane on the keel. There is no need for the arrays to have the exact same heading, roll and pitch.

The number of individual Tx and Rx modules in the two arrays depends on the chosen EM 710 configuration.

System configuration	TX modules	RX modules
0.5 x 1 degree	2 x TX1	1 x RX1
1 x 1 degree	1 x TX1	1 x RX1
1 x 2 degree	1 x TX1	1 x RX2
2 x 2 degree	1 x TX2	1 x RX2

The cables connecting the transducers to the Transceiver Unit have a standard length of 15 m, and are terminated with connectors which plug directly into the cabinet.

4.1.2 Installation philosophy

The EM 710 Multibeam echo sounder is supplied as a basic echo sounder with two relatively large transducers. While the electronic units are installed using normal tools, the transducer arrays must be located and installed depending on the vessel's design. A number of different factors related to the vessel's design must be taken into consideration during the installation planning.

The basic installation methods are:

- Gondola
- Blister
- Flush-mounted integrated into the hull
- Externally mounted with fairing(s)
- In a box keel
- Any combination of the above

See chapter *Installation examples* on page 43

A fairing will usually be added around the transducers to ensure laminar water flow without any aeration problems. A blister or gondola installation may help in avoiding air bubble blockage of the sound path under the transducers by aerated water. Blisters and gondolas may also contain additional transducers for other systems.

Normally, in a permanent installation, the cables enter the hull through tubes which are fitted with standard ship type cable glands (Brattberg, Roxtec or equivalent) to provide water tightness. The cable glands should be of the type having a pressure rating of 4 bars or more. If the tubes end below the vessel's water-line, classification requirements may require a double set of glands.

The installation of the transducer arrays must thus be planned together with the installation shipyard and/or the client.

Once the installation method is defined, the installation shipyard must provide the necessary drawings. These drawings must be approved by the vessel's classification authority.

If required, Kongsberg Maritime AS can assist with the required engineering.

4.2 Installation steps

The following steps must be taken to install the EM 710 transducer arrays:

- 1 Determine the physical location of the transducer arrays under the vessel's hull.

Locating the transducer array on page 31

Note

it is important to minimize the alongship gap between the RX and the TX arrays to improve the performance at very shallow water (to get overlap between RX and TX footprints).

2 Design the transducer installation method.

- Several methods may be used: gondola, blister, flush mounting, external mounting with fairing(s), or any combination of these. The method must be chosen according to the vessel's hull design.
- On a new vessel, the transducer arrays may be incorporated into the hull for flush mounting. On older vessels, a transducer blister is usually designed to be mounted under the hull. A gondola can also be designed.

Examples of transducer array installation methods are provided from *Installation examples* on page 43

A typical blister is shown in *Blister and steel pipe arrangements (example)* on page 34

A typical gondola is shown in *Gondola for 0.5 x 1 degree system* on page 35

3 Prepare the transducer array installation arrangement.

- The installation arrangement must be capable of accepting the two transducer frames.

4 Install the steel conduits.

The installation procedure is given on *Installing the steel conduits* on page 36

5 Install the mounting frames. Note that these are normally only required for the 0.5 degree transmit transducer.

The installation procedure is given on *Installing the mounting frames* on page 38

6 Install the transducer modules.

The installation procedure is given on *Installing the transducer modules* on page 39

7 Lay the transducer cables from the transducer modules to the steel conduits. Each cable is marked in both ends with the module's serial number and cable number.

8 Note the orientation of the transducer cable outlet from the transducer modules. Fill in the tables below.

Table 2 TX1 and TX2 Cable orientation

Module type (TX1 / TX2)	
Serial no.	
Cable orientation (Port/starboard)	

Table 3 TX1 and TX2 Cable orientation

Module type (TX1 / TX2)	
Serial no.	
Cable orientation (Port/starboard)	

Table 4 RX1 and RX2 Cable orientation

Module type (RX1 / RX2)	
Serial no.	
Cable orientation (bow/astern)	

Note

It is possible to mount the TX array(s) with the cables pointing to the port or to the starboard side. The default orientation is starboard side. (this should be used if possible, but cabling may make it difficult).

If mounting is in accordance with the default orientation, the installation heading is 0 degrees. If the TX array(s) is mounted with cables pointing to port side, 180 degrees must be added to the measured heading coming from the alignment. In this case the sign of the measured TX array installation roll and pitch angles must be inverted in the SIS installation menu.

Observe that the figures may have to be corrected after alignment measurements.

alignment on page 96

Note

For a 0.5 x 1 degree system, cables from both TX arrays must drawn in the same way (for example to the starboard side).

It is possible to mount the RX array with the cables pointing towards bow and towards stern. The default orientation is astern. (This should be used if possible, but cabling may make it difficult.)

If mounting is in accordance with the default orientation, the installation heading is the measured value coming from

the alignment. If the array is mounted with cables pointing towards bow, 180 degrees must be added to the measured heading. In this case the sign of the RX array installation roll and pitch angles must be inverted in the SIS installation menu.

Observe that the figures may have to be corrected after alignment measurements.

alignment on page 96

- 9 Pull the cables up through the steel conduits
- 10 Seal the steel conduits
- 11 Connect the cables to the Transceiver Unit.

The installation procedure is given on *Cable layout* on page 56

Figure 3 Default orientation of transducer modules and cables, top view, principle drawing

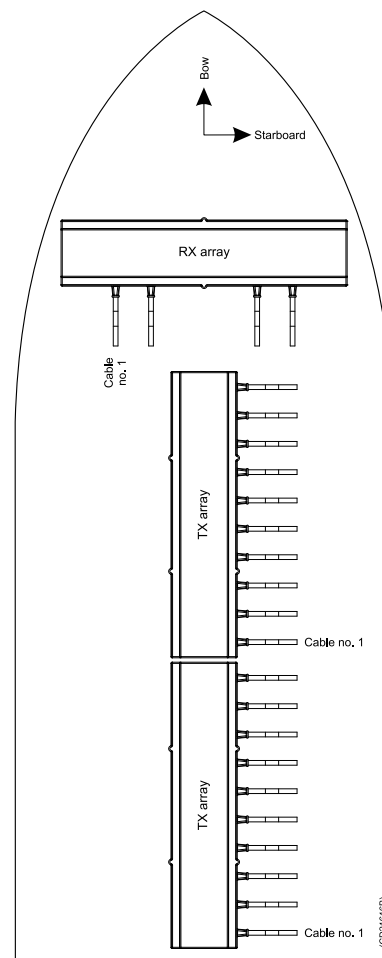

4.3 Locating the transducer array

Correct location of the system's transducer is vital for the operational performance.

A single answer to the question of where to locate the transducer arrays cannot be given. It depends very much on the vessel's construction. However, there are some important guidelines which are generally applicable.

4.3.1 The boundary water layer

The upper water layers of the sea contain a myriad of small air bubbles created by breaking waves. In heavy seas the uppermost 5-10 metres may be air-filled, with the highest concentrations near the surface. Air bubbles absorb and reflect sound waves, and may in the worst conditions block sound transmission totally.

When a vessel moves through the sea, the friction between the hull and the water creates a boundary layer. The thickness of the boundary layer depends upon the vessel speed and the roughness of its hull. Any objects protruding from the hull, and any dents in the hull, will disturb the flow and increase the thickness of the boundary layer. The flow in this boundary layer may be laminar or turbulent. A laminar flow is a nicely ordered, parallel movement of the water. A turbulent flow has a disorderly pattern, full of eddies. The boundary layer increases in thickness when the flow goes from laminar to turbulent.

Furthermore, air bubbles in the sea water are pushed down below the hull and mixed into the boundary layer. The boundary layer is thin underneath the forward part of the vessel, and increases in thickness as it moves aftwards. If the sides of the hull are steep, some of the air bubbles in the boundary layer may escape to the sea surface along the vessel sides. It is our experience that a wide and flat bottom, with a rising angle less than about 13 degrees athwartship, is prone to cause air problems for a transducer.

Sketch of boundary layer underneath the vessel on page 32 shows in principle the boundary layer of a vessel moving through the water.

The conclusion is that the transducer array should be mounted as deep as possible, and in the forward part of the hull.

4.3.2 Propeller noise

The propulsion propeller is the dominant noise source on most vessel types. The noise is transmitted through the sea water, and may in extreme cases reduce the maximum range capability of the EM 710.

Figure 4 Sketch of boundary layer underneath the vessel

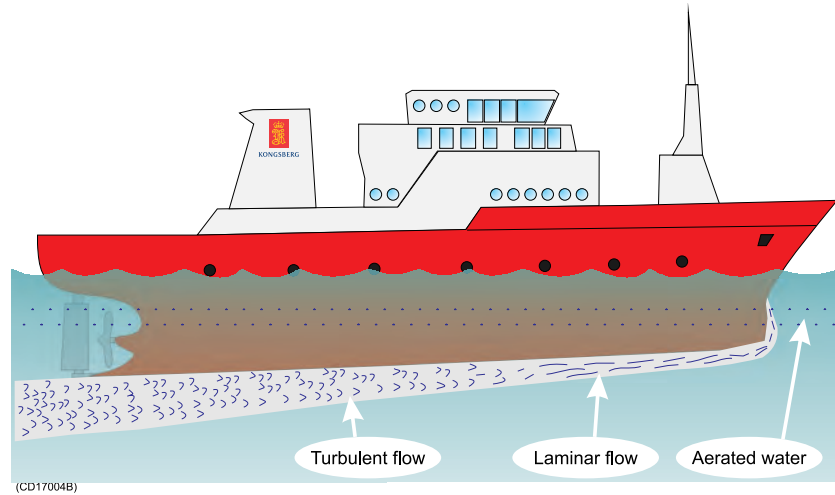

The transducer arrays should therefore be placed far away from the propeller, which means on the forward part of the hull. Positions outside the direct line of sight from the propeller are favourable.

When a bow thruster operates, the noise and cavitation bubbles from its propellers may make an echo sounder useless. Even when the bow thruster is not in operation, its tunnel creates turbulence.

The tunnel may also drag air under the water, which escapes and make noise.

The transducer array should be placed with large distance from the bow thruster.

4.3.3 Noise from protruding objects on the hull

Objects protruding from the hull, such as zinc anodes, sonar transducers or even the vessel's keel, generate turbulence and flow noise. Also holes and pipe outlets are noise sources. They may act as resonant cavities amplifying the flow noise at certain frequencies.

Thus the transducer array should not be located in the vicinity of such objects, and especially not close behind them.

4.3.4 Summary

Some of the above guidelines may be conflicting, and each case has to be treated individually in order to find the best compromise.

Figure 5 Recommended location of the transducer array on the hull

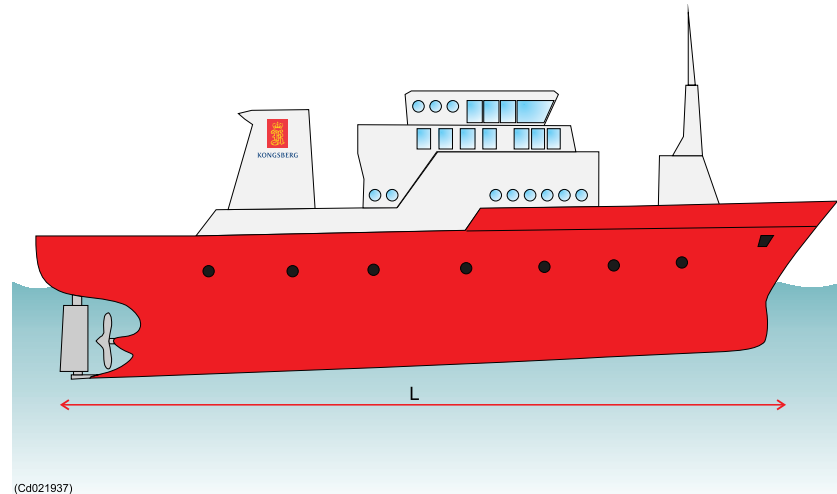

The possibility of getting air bubbles in front of the transducer array is the most important factor.

If the vessel hull has a bulbous bow, this may well be a good transducer array location, but also in this case the flow pattern of the aerated water must be taken into consideration. Often the foremost part of the bulb is preferable as shown below.

Figure 6 Transducer array located on a bulbous bow

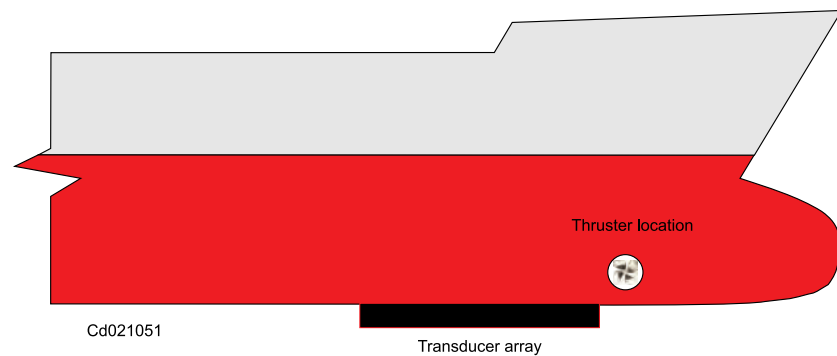

If a nominal horizontal mounting of the transducer array is desired, the transducers can be mounted parallel to the keel. Most ships have a positive design pitch of 0.5 to 2°. Backward tilt is not recommended, it may limit the operational weather window.

The recommended transducer array location is in the fore part of the hull, and normally follow the keel line with respect to tilt.

Figure 7 Blister and steel pipe arrangements (example)

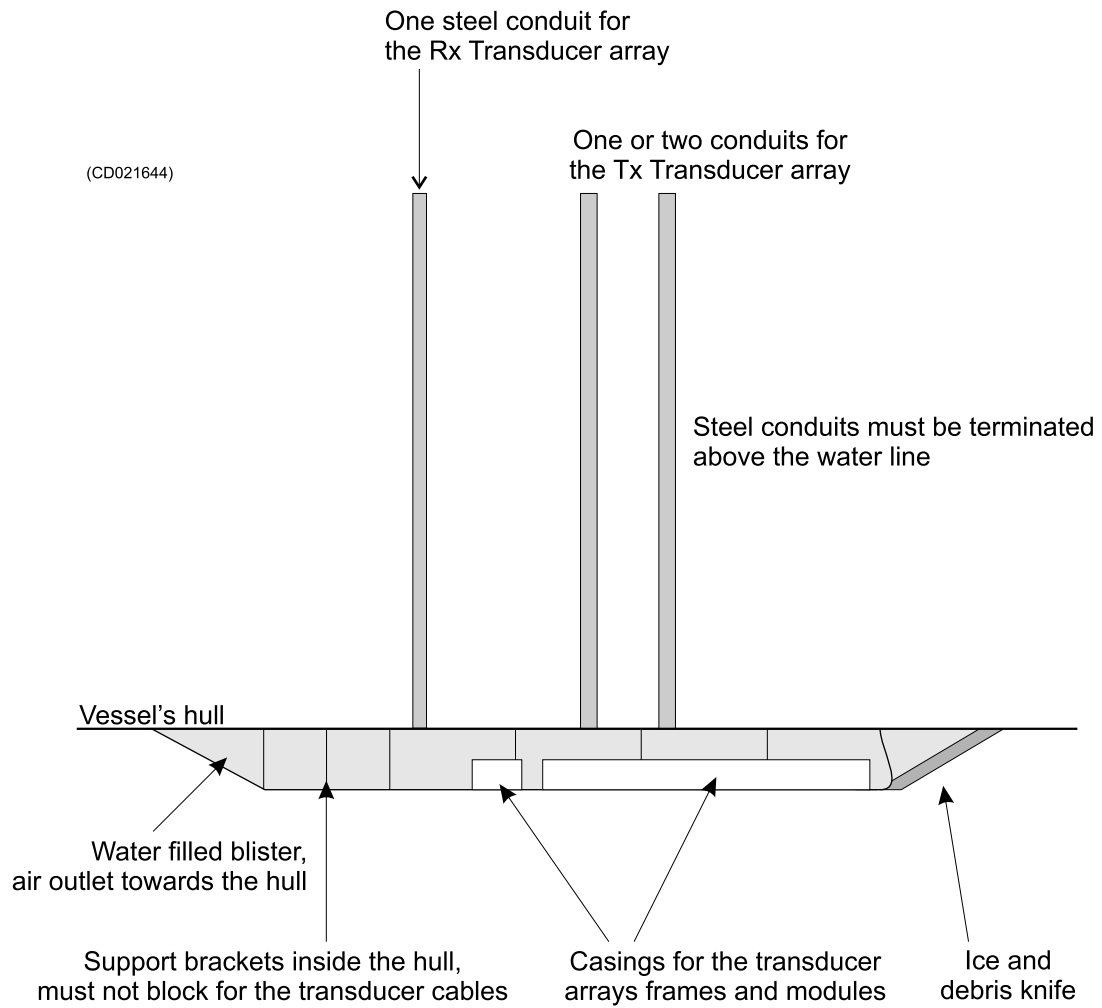
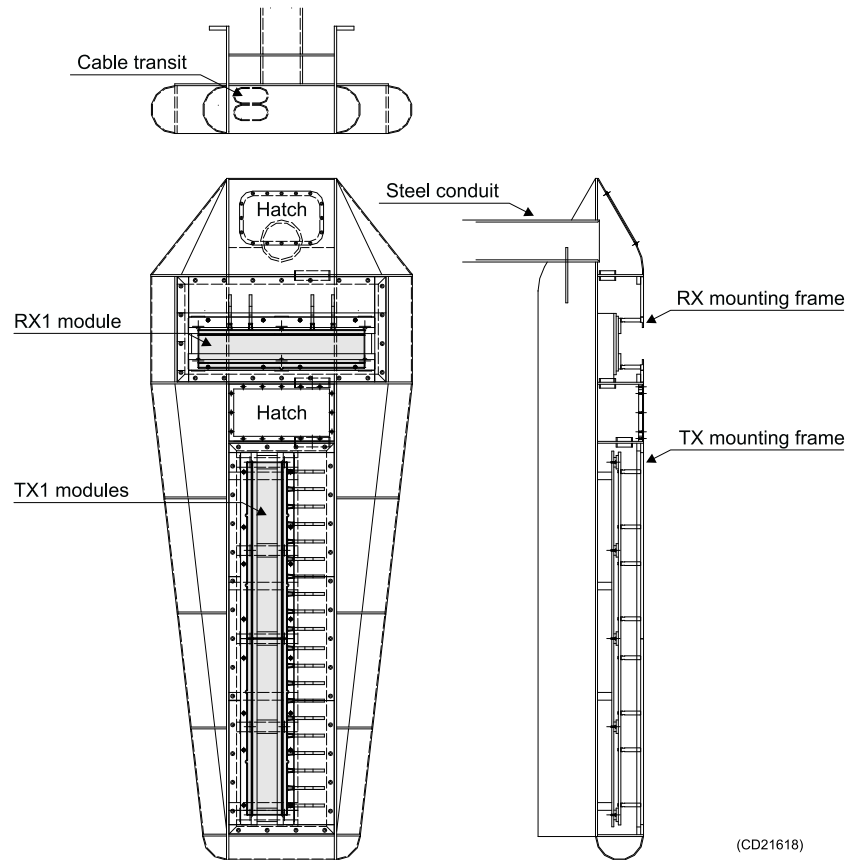

Figure 8 Gondola for 0.5 x 1 degree system



Flatness before and after installation of arrays in the frame

- 1 Install the frame under the hull

Installing the mounting frames on page 38

- 2 Check the flatness of the frame

The mounting structures must not deviate from a flat surface more than ± 0.2 mm. This can be checked by measuring the relative vertical positions of the module mounting bars on the frames. If the deviations are too large, this has to be corrected before the modules are put in place

Flatness of the frame on page 36

- 3 Install the modules

When the installation of the transducer arrays are done in the frame, the transmit module has to be installed along the keel and the receiver module has to be installed across the keel. Therefore the angle between the transmit and receiver transducer has to be 90° in a “T” or a “L” module.

During the installation, check that the procedure *Installing the transducer modules* on page 39 are followed.

- 4 Check the flatness of the installation of the modules in the frame

Figure 9 Flatness of the frame

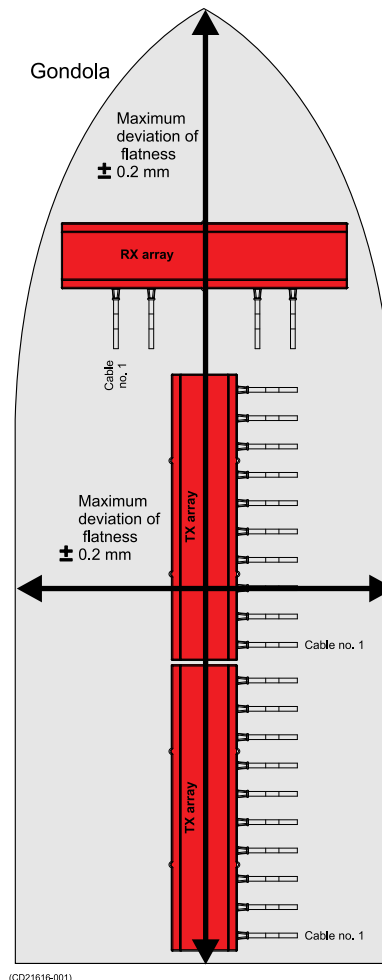

- 5 After the installation of all modules in the frame, check the complete flatness of the frame and arrays surface.

The deviation shall not exceed ± 0.2 mm in any direction of the surface.

4.4 Installing the steel conduits

The transducer cables connect through the vessel's hull using steel conduits. The steel conduits are welded to the vessel's hull. The top of each conduit must be closed and sealed to preserve the watertightness. This can be done with a "Bratberger", "Roxtec" or a similar sort of sealing device.

The installation of the steel conduits must be properly planned, and all plans and drawings must be approved by the vessel's classification authority. This is always the yard's responsibility.

For the principles, see *Blister and steel pipe arrangements (example)* on page 34

The steel conduits must be designed to fit each individual vessel. They are not included with the system delivery. The steel conduits must therefore be both provided (or manufactured) and installed by the installation shipyard. The number of steel conduits depends on the chosen system configuration and the internal diameter of the conduits.

- a 0.5° x 1° system (2 TX1 modules and 1 RX1 modules) requires two Tx conduits and one Rx conduit.
- a 1° x 1° system (1 TX1 modules and 1 RX1 modules) requires one Tx conduits and one Rx conduit.
- a 1° x 2° system (1 TX1 modules and 1 RX1 modules) requires one Tx conduits and one Rx conduit.
- a 2° x 2° system (1 TX1 modules and 1 RX1 modules) requires one common Tx and Rx conduit.

4.4.1 Logistics and references

Safety - Refer to the general safety procedures.

Qualifications - Mechanical workers

Ship location - Dry dock

Special tools - None

Drawings *Installation drawings* on page 109

4.4.2 Procedure

How to mount the steel conduits

- 1 Design the steel conduits with appropriate length and diameter to fit the echo sounder.
- 2 Mount the steel conduits from the vessel hull and up towards the sonar room and the EM 710 Transceiver Unit.
 - The steel conduit(s) should have an outer diameter of approximately 219 mm and an inner diameter of approximately 197.0 mm.
 - The steel conduits are laid as required by the vessel structure and the location of the blister and sonar room. The conduits may be bent if required, but not more than 30 degrees. Note however that one or two sharp bends on the conduits may require a larger diameter.
 - The upper opening of the steel conduits should be above the vessel's water line. If the openings of these conduits are under the water level, then special acceptances are needed from the classification soc.

- 3 Close the top of the steel conduits with a seal.
 - Kongsberg Maritime recommends the use of sealing from Roxtec, Bratberg or similar. This system is described in the Appendices chapter in this manual.

4.5 Installing the mounting frames

Mounting frames are designed to house the individual transducer modules.

A mounting frame is normally required for the 0.5 degree transmit transducer as it consists of two separate modules. This should not be necessary for the other transducer models. These are self-contained units and due to their internal (very strong) carbon-fibre structures, they may be bolted directly to a flat mounting plate (for example).

While the transducer modules are mounted into the frames, the frames require casings. The casings must be individually designed for each vessel, and it is not a part of the system delivery. The casings must therefore both be provided (or manufactured) and installed by the installation shipyard.

The installation must be carried out according to arrangement drawings designed for the specific vessel. Refer to the drawings included in the Drawing File, and the applicable drawings prepared by the installation shipyard.

4.5.1 Logistics and references

Safety - Refer to the general safety procedures. Note that the units are heavy !

Personnel - Trained mechanical workers

Ship location - Dry dock

Special tools - None

Drawings - Refer to the previously mentioned drawings in the Drawing File.

1° mounting frame assembly RX module on page 112

2° mounting frame assembly TX/RX module on page 114

4.5.2 Procedures

Note _____

The mounting frames must be handled with care. Please observe normal safety precautions for dockyard work and welding.

- 1 Manufacture the casings according to the attached production drawing.

- 2 Alter the drawings and the design as required to fit the vessel and the chosen installation method.
- 3 Mount the casings in the blister or integrated into the hull.
- 4 The mounting frames must be bolted onto the flat bars inside the casing.

The number of flat bars depends on the length of the array.

Note _____

The mounting frames must be installed with correct orientation!

- 5 The mounting frames must be bolted properly to the bars. The frames are fastened by M12 hex cap screws. Use a torque of approximately 74 Nm.
- 6 Check that the frames are mounted completely flat. No point on the frames may deviate from the horizontal plane with more than ± 0.2 mm. Refer *alignment* on page 96 chapter for a proposed measuring method.
- 7 Repeat the previous step until the alignment procedure has been performed successfully.

4.5.3 Installation accuracy of frames

Check that the frames are mounted completely flat. This is very important for the calibration of the system and the results of the data information in SIS.

No point on the frames may deviate from the horizontal plane with more than

± 0.2 mm. This is very important to follow.

4.6 Installing the transducer modules

To make the installation of the transducers easier, they are built with standard modules

- 1 TX modules (type TX1 or TX2)
- 2 RX modules (type RX1 or RX2)

The two transducer module types are identified by their unique registration numbers, which are moulded into the rear of the element.

The transducer modules are assembled in the mounting frames especially designed for this purpose. The modules are secured with steel brackets, while the cables are pulled out on the side of each array.

4.6.1 Logistics and references

Safety - Refer to the general safety procedures. Note that the individual units are heavy !

Personnel - Trained mechanical workers and installation engineers from Kongsberg Maritime AS.

Ship location - Dry dock

Special tools - None

References - Refer to the following drawings in the Drawing File:

Note _____

Note that engineers from Kongsberg Maritime must be present to install the transducer modules.

4.6.2 Procedure

How to install the RX and TX transducer array modules

Observe normal safety precautions for dockyard work.

Caution _____

The transducer modules and the cables must be handled with care! The modules are heavy!

DO NOT LIFT THE MODULES BY THE CABLE!

Tx transducer modules

Note _____

When installing Tx transducer modules, fill in the "Location of Tx modules" table!

- 1 If using mounting frames, hold the first transducer module up in the frame, else mount the module directly to the hull.
- 2 Pull out the transducer cable, and guide them out through the side of the mounting frame (if applicable).
- 3 Either (when using mounting frames) :
 - Place the transducer modules into the frames and fasten them by the stay rods and clamping lists. The clamping lists are fastened to the mounting frames by M10 bolts with self lock treads. Use a maximum torque of 42 Nm and lubricate with Loctite 242.

Or (when mounting directly in the hull)

- Secure the transducer module in place with the brackets, one on each side. Use torque approximately 70 Nm.
- 4 Mount the next transducer module next to the previous. (only applicable for a 0.5 x 1 degree system).
 - The gap between the individual modules is determined by the appurtenant mounting frame.
 - If not using a mounting frame, mount the modules so that this gap equals 1 mm exactly.
 - 5 Check that the transducer cables pass through the casing in such a way that they are not exposed to wear and tear. Secure as required.
 - 6 Check that all bolts are properly fastened.
 - 7 After installation measure the location of the transducer modules and their angular orientation in the vessel coordinate system accurately.

RX transducer modules

Note _____

When installing the RX transducer module, fill in the “Location of Rx modules” table!

- 1 Perform the same procedure as described above.

Figure 10 Transducer mounting principles

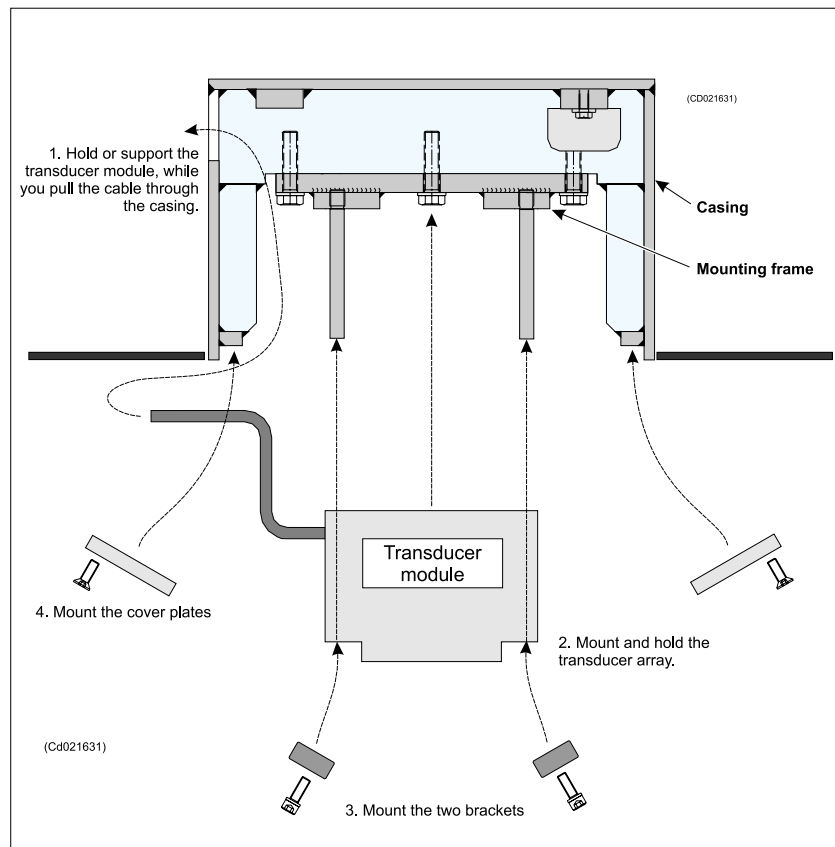

5 INSTALLATION EXAMPLES

This chapter provides a number of examples for transducer array installation. Installation procedures are also defined.

Topics

- *Transducer blister* on page 43
- *Gondola* on page 45
- *Flush mount* on page 46
- *Fairing* on page 47
- *Steel box* on page 47

5.1 Transducer blister

The transducer arrays should be mounted underneath the vessel. To achieve this, you can design and manufacture a streamlined transducer blister, and mount it under the vessel's hull. This is a well proven way, when refitting a vessel with a EM 710 system.

Refer to *Hatches for access to the steel conduits (top view)* on page 44 for the principles.

Note

The inside surface of the blister must be protected with appropriate protective paint and an adequate amount of zinc.

5.1.1 Logistics and references

Logistics and references

Logistics and references Safety - Refer to the general safety procedures.

Personnel - Trained mechanical workers

Ship location - Dry dock

Special tools - Torque wrench

Protection - Protective paint, zinc anodes

References - None

Procedure

- 1 Design and manufacture the transducer blister.
 - The blister must hold the two casings; one for the Tx and one for the Rx transducer arrays. The appropriate drawings describing these casings are included in the Drawing File.
 - The blister will be water filled. To let the air escape, make a suitable hole in the rear end close to the vessel's hull.

- Our recommendation is to place an “debris knife” in the forward end of the blister.
- 2 Prepare the inside surface protection of the blister. Paint with protective paint, and mount zinc anodes.
 - 3 Mount the transducer blister under the vessel’s hull.
 - 4 Check the inside surface protection of the blister.
 - Add paint or zinc as required.
 - 5 Protect the outer surface of the blister.

Figure 11 Hatches for access to the steel conduits (top view)

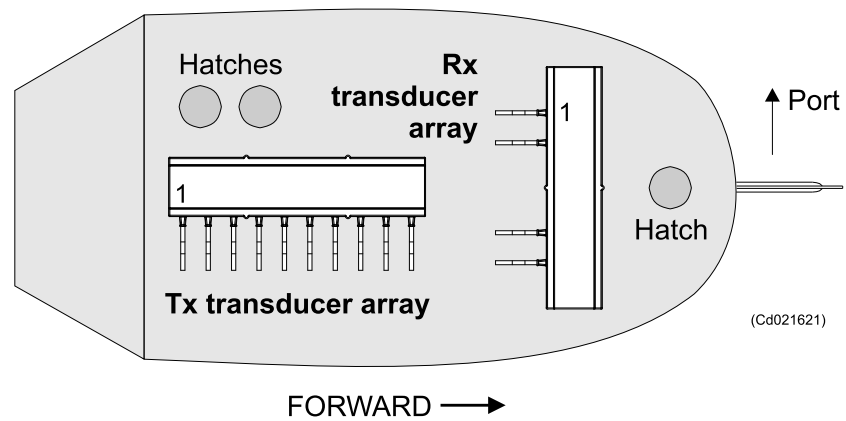

5.2 Gondola

A gondola is a streamlined pod mounted under the hull of the ship. It can either be welded or bolted under the hull plates.

The idea is to make a gap between the ships hull and the transducers.

This gap shall prevent aerated water around the transducers, and thus generate an operational weather window as wide as possible.

See *Gondola for 0.5 x 1 degree system* on page 35

5.2.1 Logistics and references

Logistics and references

Logistics and references Safety - Refer to the general safety procedures.

Personnel - Trained mechanical workers

Ship location - Dry dock

Special tools - Torque wrench

Protection - Protective paint, zinc anodes

References - None

Procedure

- 1 Design and manufacture the transducer gondola.
 - The gondola must hold the two casings; one for the Tx and one for the Rx transducer arrays. The appropriate drawings describing these casings are included in the Drawing File.
 - The gondola will be water filled. To let the air escape, make a suitable hole in the rear end close to the vessel's hull.
 - Our recommendation is to place an "debris knife" in the forward end of the gondola.
- 2 Prepare the inside surface protection of the gondola. Paint with protective paint, and mount zinc anodes.
- 3 Mount the transducer gondola under the vessel's hull.
- 4 Check the inside surface protection of the gondola.
 - Add paint or zinc as required.
- 5 Protect the outer surface of the gondola.

Figure 12 Gondola – 1 x 2 degree system



5.3 Flush mount

The transducer arrays may be mounted flush with the vessel's hull. In order to do this, the shipyard must design a framework inside the hull to support the casings. The arrays must then be mounted so that their faces are flush with the outer hull.

Note _____

This installation method may prove unsuccessful due to aerated water blocking the signal path to and from the transducers. Thorough research on the vessel's hull design and the acoustic conditions must be made before attempting this installation method.

5.4 Fairing

The transducer arrays may also be mounted directly under the vessel's hull and then "streamlined" with fairing. This installation method has proven successful in former multibeam echo sounder installations. The required installation drawings must be made by the installation shipyard or by third-party ship designers.

5.5 Steel box

The transducer arrays may be mounted in the steel boxes. The steel boxes must be surface treated as the vessel's hull.

Vessels with a box keel may use this for transducer installation. The box keel is already the deepest part of the vessel. If the box keel is too narrow to accommodate the transducer, it can be widened, either symmetrically or to one side only. In the last case the installation could also be described as a blister merged into the keel.

Figure 13 Box keel (2 x 2 degrees system)

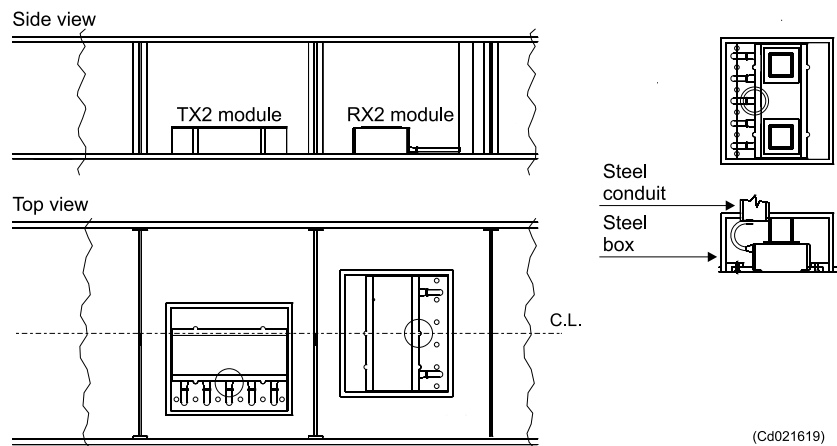

6 SYSTEM UNITS

Topics

- *Operator station* on page 48
- *Transceiver Unit* on page 48
- *Remote Control Junction Box* on page 54

This chapter describes the installation of the EM 710 Transceiver Unit in the equipment or operation room, and the Operator Station in the operation room.

The Remote Control Junction Box installation is also described.

Drawings showing the system and the physical dimensions are included in the text.

Note

Kongsberg Maritime strongly recommends that an Uninterruptible Power Supply (UPS) is used to power the Operator Station.

6.1 Operator station

The EM 710 Operator Station consists of a Kongsberg PC based work station. Main units are computer chassis, display monitor, keyboard, mouse, units for external data storage.

Location

It is recommended to place the Operator Station in a room with environmental conditions similar to those required for extended human occupation. The Operator Station is usually mounted in the operation room, in a rack.

Installation

No specific installation procedures exist for the Operator Station. However, you must install the units so that they are properly physically supported and protected for shock and vibration due to sea conditions.

6.2 Transceiver Unit

This chapter presents the general installation procedures for the EM710 Transceiver Unit.

The Transceiver Unit contains all transmit and receive electronics. It comprises one or two 19" sub-racks contained in a cabinet designed for bulkhead or deck mounting.

Note

The guidelines for installation presented here must be regarded as a base for detailed vessel specific plans prepared by the installation shipyard. These plans should include drawings, instructions and procedures specific to the ship in which the equipment is to be installed.

6.2.1 Location

The EM 710 Transceiver Unit is normally installed in the vessel's "sonar room" close to the transducer arrays. This room must be dry and free from excessive dust and vibration. Maximum humidity of 80% is recommended. Good ventilation for the equipment cooling must be provided.

Kongsberg Maritime recommends that this room is chosen close enough to the transducer arrays so that you do not need to extend the transducer cables.

The cabinet must be mounted on a bulkhead or on mounting brackets welded to the bulkhead. Ensure that sufficient space is provided around the unit to allow the unit's doors to open fully.

Where space is restricted, it is possible to install the two 7H high sub-racks without using the supplied cabinet. However, it is then the responsibility of the customer to ensure adequate environmental protection (heat, humidity, vibration, EMC etc.) of the sub-racks.

The Transceiver Unit cabinet is fitted with a hinged front door and a rear protection cover. This gives you access to the circuit boards from both sides.

The unit is mounted on a support frame at the factory. This frame is mounted on the bulkhead with two shock absorbers; one mounted on top of the frame and one at the bottom.

Note that the space requirements for the Transceiver Unit must be adhered to.

6.2.2 General information

The Transceiver Unit cabinet is fitted with a hinged front door and a rear protection cover. This gives you access to the circuit boards from both sides.

The unit is mounted on a support frame at the factory. This frame is mounted on the bulkhead with two shock absorbers; one mounted on top of the frame and one at the bottom.

Note that the space requirements for the Transceiver Unit must be adhered to. *Transceiver Unit Outline dimensions* on page 127

6.2.3 Logistics

- **Safety** – Refer to the general safety procedures. Note that the unit is heavy.
- **Personnel** – Trained mechanical/electrical workers
- **Ship location** – In dry dock or at quay. The watertight integrity of the ship will not be affected.
- **Special tools** – Special wrenches, lifting equipment
- **Reference** – None
- **Drawings** – Refer to the drawing file

Caution

The cabinet is heavy. Ensure that correct lifting equipment is available.

6.2.4 Procedure

How to mount the Transceiver unit cabinet

- 1 Mark the location of the holes for the upper and lower shock absorber on the bulkhead.

Figure 14 Fixing holes for one shock absorber

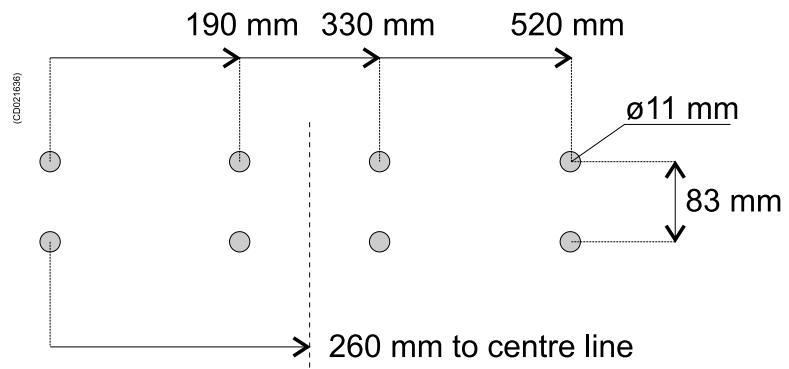
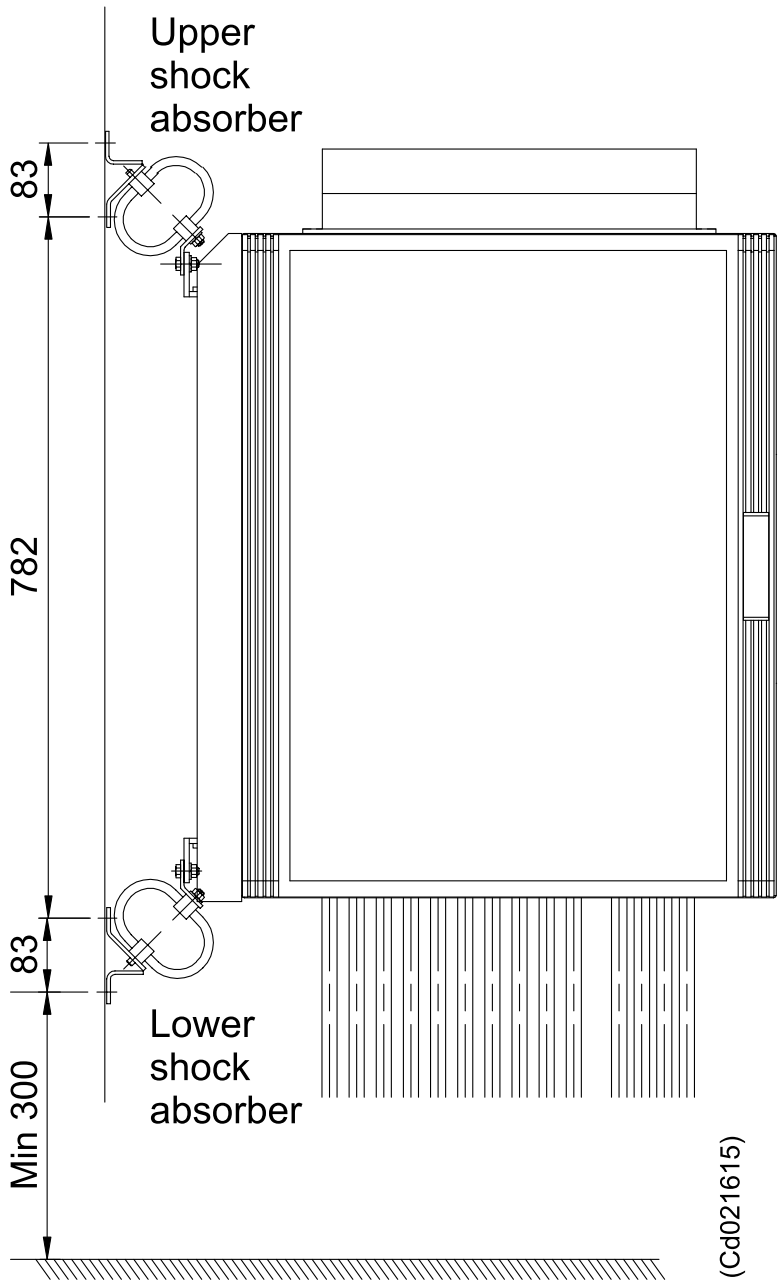

Figure 15



- 2 Drill 11-mm holes, eight (8) for each shock absorber.

Caution _____
Always check on the other side of the bulkhead before drilling holes !

- 3 The Transceiver Unit is delivered as a complete unit with shock absorbers. Mount the unit to the bulkhead with M10 bolts. These bolts must be supplied by the shipyard.

- As the Transceiver Unit is heavy, a lifting arrangement (articulated jack or similar) must be used.
 - The foundation onto which the Transceiver Unit is mounted will determine the correct torque to be applied to the bolts.
- 4 Alternatively, the shock absorbers can be mounted to a pair of specially designed support brackets.
ref drawing *Transceiver Unit mounting bracket* on page 131

How to mount the compact transceiver unit – 2 x 2 degree system

- 1 Follow the same procedure as for the ordinary transceiver unit cabinet

Figure 16 Fixing holes for one shock absorber

Detail A

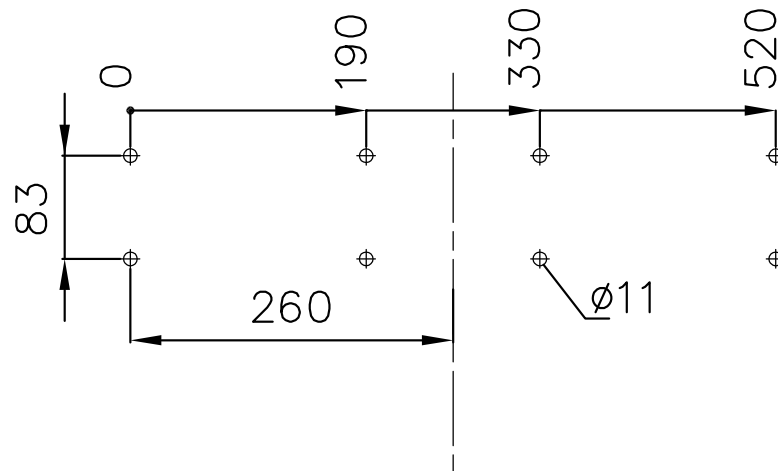
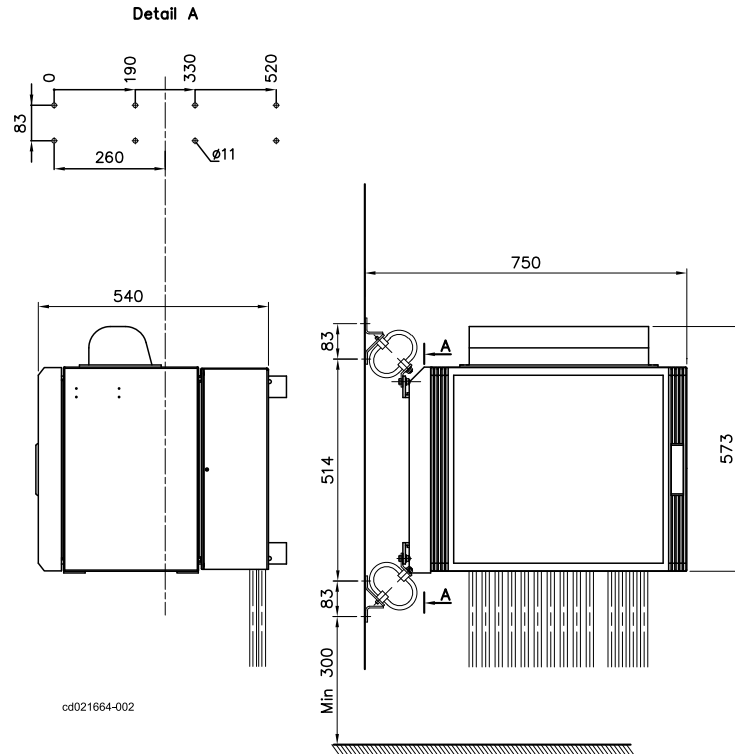

Figure 17 Transceiver Unit 2 x 2 degree system – Outline dimensions



How to mount Transducer array cables and interfaces

All external cables (power cables, interface cables, transducer cables) enter the Transceiver Unit at the rear side. The cables must be fastened to the cable clamp.

- 1 Prepare the support brackets to receive the transducer array cables on the cabinet.
- 2 Mount the cables according to the cable plan.
 - Make sure that the transducer cable tables are filled in correctly. *Cable layout* on page 56
- 3 Thread the cables through the dedicated apertures in the cable clamp *Transceiver Unit cable clamp* on page 133

Note _____

It is recommended to start threading the innermost cables

- 4 Tighten the M10 bolts with spring washers and nuts to close the secure the cable clamp.

6.2.5 Surface preservation

All metal surfaces which are likely to corrode should be painted. This includes welds, base frames and support brackets. Make appropriate cautions to avoid spilling of paint on the cabinet

6.3 Remote Control Junction Box

This chapter presents the general installation procedures for the Remote Control Junction Box.

The Junction Box is a steel cabinet. The front door opens towards left, while the cables enter through the bottom of the cabinet.

6.3.1 Location

The Remote Control Junction Box will normally be located in the vicinity of the Operator Station. It holds the interconnection between the various units in the EM 710 system, and may also contain the master on/off switch for the entire system.

6.3.2 General information

The Remote Control Junction Box cabinet's total height is 300 mm. *Junction Box – outline dimensions* on page 132

6.3.3 Logistics

Safety - Refer to the general safety procedures.

Personnel - Trained mechanical/electrical workers

Ship location - No recommendations. The watertight integrity of the ship will not be affected.

Special tools - None

References - None

Drawings - Refer to the Drawing file

How to install the Cabinet

Caution

Always ascertain what is on the other side of bulkheads and decks before drilling or welding.

- 1 Drill the required holes in the selected bulkhead, each hole capable of taking an M8 bolt. The bolts are included with the cabinet.
- 2 When the preparations for the bolts have been completed, position the cabinet and mount and tighten the securing bolts.
- 3 Use shake-proof washers, and tighten the bolts to a torque of approximately 50 Nm.

How to mount the cabling

Refer to the cable layout and interconnection documentation for sockets and connections.

Note

All power must be switched off prior to the cable installation.

All cables must be available properly installed in cable ducting. Note should be taken not to exceed the physical limitation of the cables. When securing the cable installation, make sure that enough cable slack is provided to allow the cabinet to move on its shock absorbers.

- 1** Introduce the cables into the appropriate cable glands on the cabinet, and connect them to the relevant terminals, ensuring enough slack is left to permit alterations, maintenance etc.
- 2** Ensure the cable glands are reassembled correctly, and that the cable screens are fitted securely into the glands.
- 3** Check all wiring, especially the power supplies, before switching power onto the unit.

7 CABLE LAYOUT

Topics

- *System cabling* on page 57
- *Operator Station cables* on page 58
- *Transceiver Unit cables* on page 60
- *Transducer cables* on page 89
- *Cable specifications* on page 92

The standard cables used between the EM 710 system units and between the units and their external devices are shown here. For larger installations where the EM 710 is a subsystem, the cables will also be shown in the cable layout plan and interconnection diagram specific for the vessel into which the system is installed.

Note

All cable connections may have to be made in accordance with the guidelines laid down by the vessel's classification society.

If no such guidelines exist, Kongsberg Maritime AS recommends that Det norske Veritas (DnV) Report No. 80-P008 «Guidelines for Installation and Proposal for Test of Equipment» be used as a guide.

7.1 System cabling

Cable layout

The interconnection cables are identified on the cable plan drawings. The following pages give a brief description of each cable. In the Drawing file, each cable is identified with the appropriate terminations and required specifications.

Shipyard and system cables

Each individual cable is identified on the cable plan. The cables fall into two categories:

- Cables provided by the installation shipyard or owner
- System cables supplied with the delivery

Shipyard cables

The cables that must be provided by the shipyard or owner are identified as such in the descriptions. Note that the cable specifications given are the minimum specifications.

For each cable, the following information is provided:

- Connection to be made on each end of the cable (including system unit, terminal board identification and plug/socket to be used)
- Number of cores
- Recommended cable type
- Minimum cable specifications

The appropriate considerations must be taken to suit special requirements. Kongsberg Maritime accepts no responsibility for damage to the system or reduced operational performance if this is caused by improper cabling.

System cables

Several cables will be supplied with the system. Such cables normally comprise power cables for peripheral equipment, and interconnection cables for computers and/or workstations. These cables will normally be delivered with the hardware.

Several cables will be supplied with the system. Such cables normally comprise power cables, and interconnection cables for computers and/or workstations. These cables will normally be delivered with the units.

7.2 Operator Station cables

The illustration and the list below specifies each cable used on the EM 710 Operator Station. References are made to detailed cable drawings.

Note that this information includes several cables that may not be in use on all installations.

Figure 18 Operator Station cables

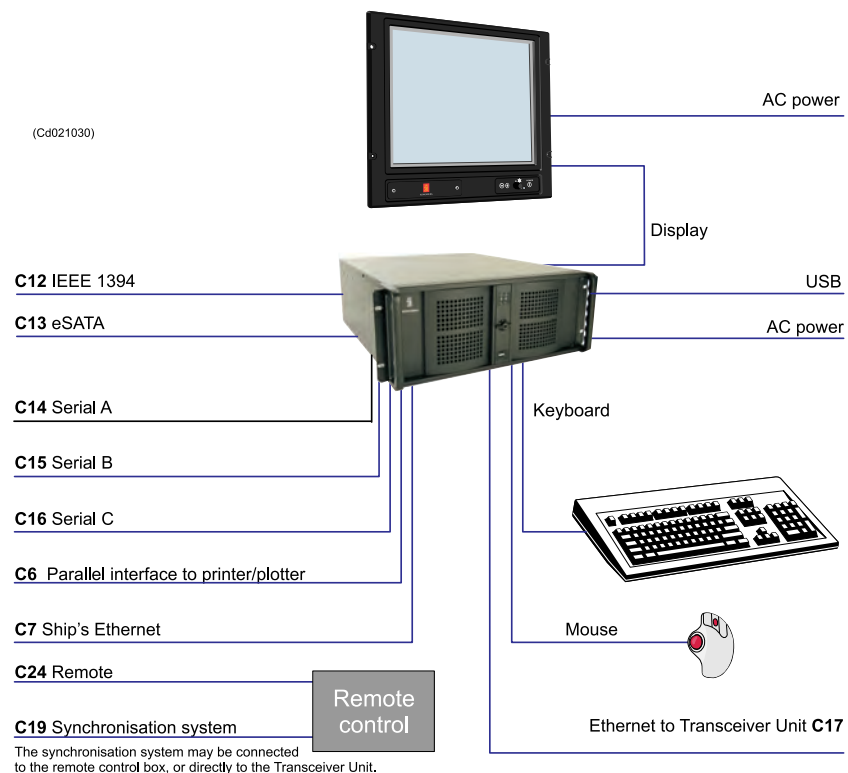

C6 - Printer or plotter

The Operator Station only provides one parallel interface to a printer or plotter. In most cases, printers and plotters are connected directly to the ship's Ethernet network.

When applicable, the cable is provided by the manufacturer.

C7 - Ship's Ethernet

The Operator Station is equipped with two Ethernet ports interface boards, one is used to communicate with the ship's Ethernet while the other (C17) is used to communicate with the Transceiver Unit.

The Ethernet cables must be provided by the installation shipyard. For cable details, see *Ethernet cable with RJ45* on page 142

C8 / C9 - AC power

These are AC mains cables.

All AC mains cables are normally supplied by the manufacturer.

C12 - eSATA

Hard disk – all data is initially stored on a pair of high performance SATA disks.

These disks are run in a RAID1 configuration, thus ensuring against loss of data even if one disk should fail.

C13 - IEEE 1394 / Firewire

High-performance storage with triple interface and simple backup.

External 6-pin 1394 connectors (2) with hot-plug capability.

C14 - Serial A

This serial line is intended for a sound speed probe. If a sound speed probe is not used, the serial line may be used for other purposes.

See *Generic RS-232 Serial line* on page 134

The cables must be provided by the installation shipyard.

C15 - Serial B

This serial line is intended for a tide/depth sensor. If such a sensor is not used, the serial line may be used for other purposes.

See *Generic RS-232 Serial line* on page 134.

The cable must be provided by the installation shipyard.

C16 - Serial C

This serial line is intended for output to an autopilot or of depth to other devices.

See *Generic RS-232 Serial line* on page 134.

The cable must be provided by the installation shipyard.

C17 - Transceiver Unit RJ-45 interface

The Operator Station has two Ethernet outlets. One is used to communicate with the ship's Ethernet (C7) while the other C17 is used to communicate with the Transceiver Unit.

See *Ethernet cable with RJ45* on page 142.

The cable must be provided by the installation shipyard.

C19 - Synchronisation system

Refer to the Transceiver Unit cabling.

C24 - Remote

Refer to the Transceiver Unit cabling.

7.3 Transceiver Unit cables

The illustration specifies each cable used on the EM 710 Transceiver Unit. References are made to detailed cable drawings.

Note that this information includes several cables that may not be in use on all installations.

Also note that several cables interconnect the upper and lower sub-racks. Such cables will have a different denomination in each end.

Figure 19 Transceiver Unit - overview of interfaces

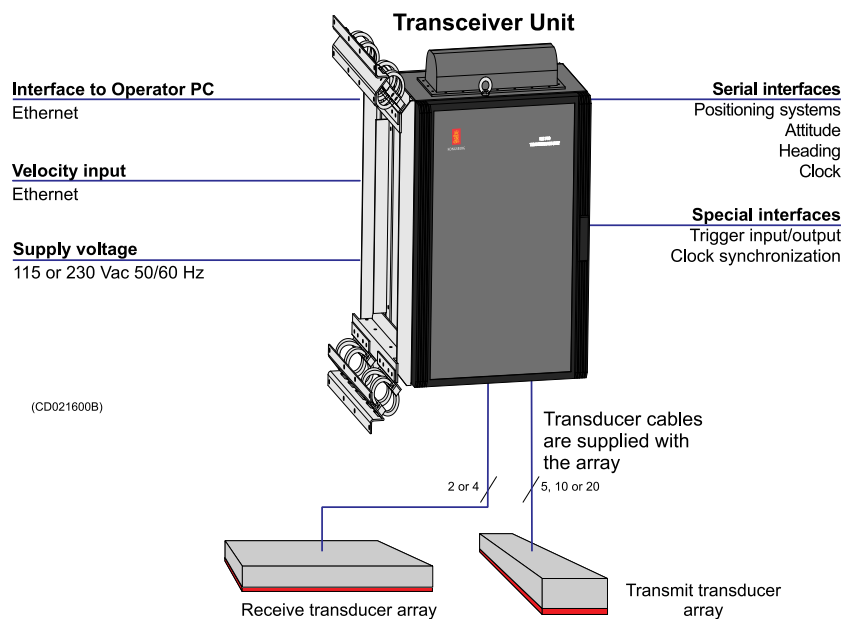

Internal cabling made at the factory:

- 1 Front side:
 - Ethernet cables that connects the different plug in boards.
- 2 Rear side:
 - One control signal cable between sub-racks
 - AC power cables between the sub-racks

7.3.1 Transceiver Unit – front view

The cabling at the front of the TRU is installed at the factory.

Figure 20 Transceiver Unit front view – 0.5 x 1 degree

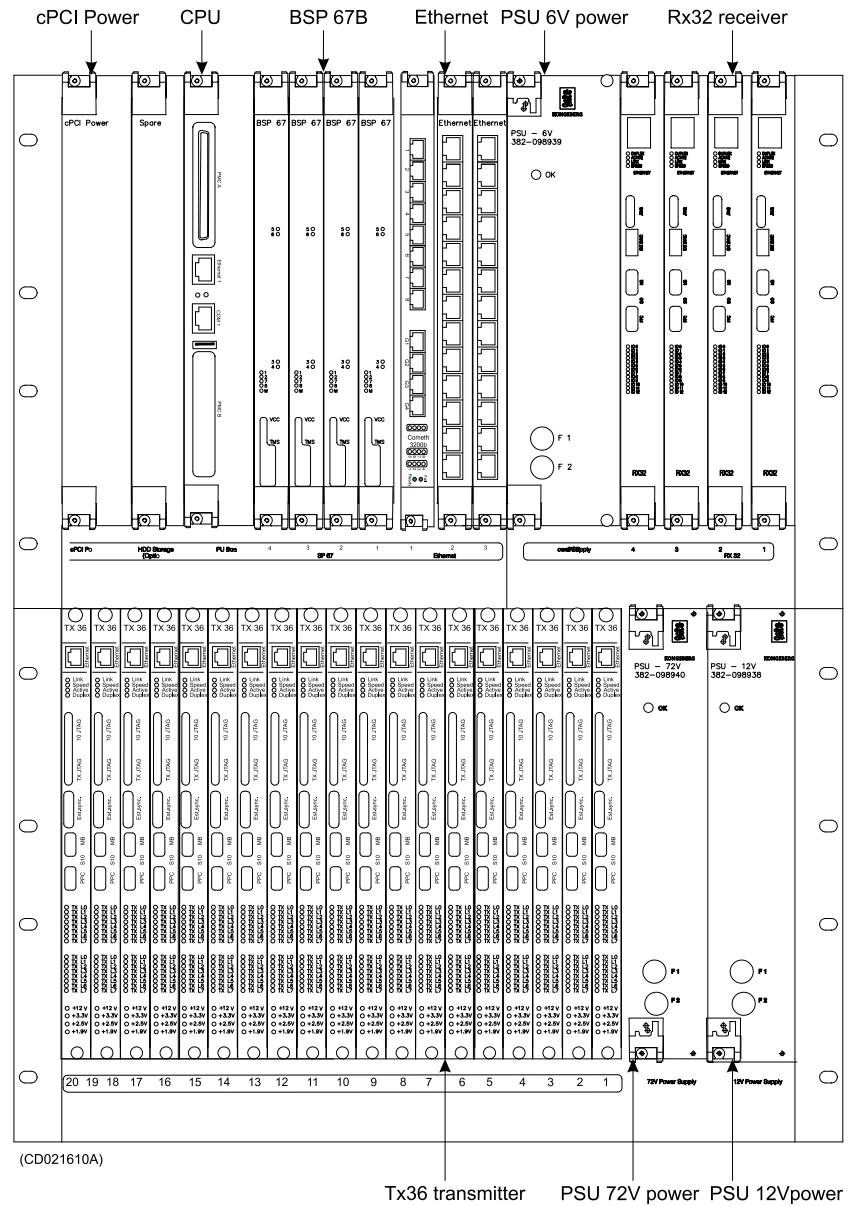

7.3.1.1 cPCI Power Supply

Purpose and description

This is a standard 500 W cPCI Power Supply. Its main purpose is to supply DC output to the CPU, BSP 67B, RX32 and Ethernet Switch circuit boards.

Figure 21 Power One



External connections

- None.

7.3.1.2 CPU Board with PMC Module

Figure 22 CPU Board

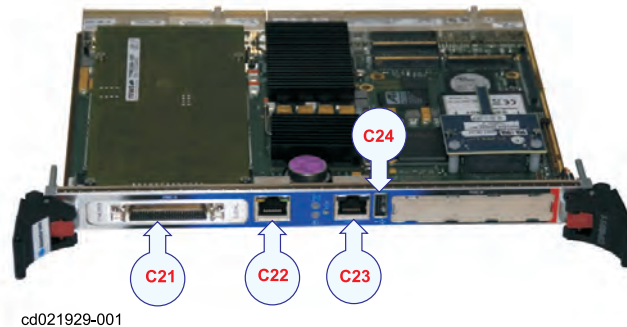

External connections

- **C21 - PMC I/O Interface (TPMC866–10) – not used**

The TPMC866–10 cable is equipped with a 50-pin connector.

- **C22 - Ethernet**

The Ethernet cables are equipped with standard RJ-45 connectors. The CPU board has one Ethernet port (ETH1) in the front.

C22 connects to ETH1 for communication with one of the Ethernet Switch Boards. The cable C22 is provided by the manufacturer, and it is a part of the internal cabling

For cable details, see *Ethernet cable with RJ45* on page 142

- **C23 - Serial line (COM1) — not used**

This is a serial line terminated in a RJ 45 connector. COM1 is software selectable for RS-232 or RS-422/485 operation.

- **C24 - USB — not used**

The USB cable is equipped with a standard USB2 connector. One USB channel is available at the front panel of the CPU board. This cable is normally not used.

7.3.1.3 BSP 67B Board

Figure 23 BSP 67B Board

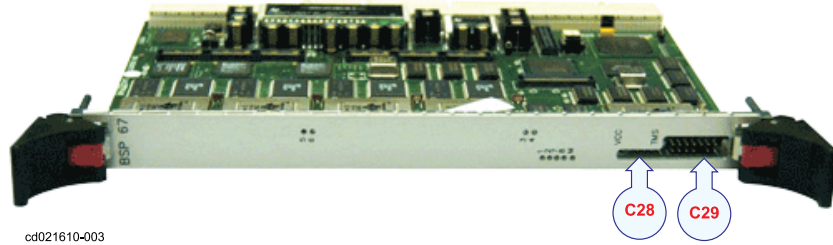

- **C28 - VCC to TMS** For FPGA programming and test purpose

This cable is connected to the VCC slot to provide a JTAG interface to the FPGA modules on the BSP 67B board. The signals of the VCC slot are available at a 36-pin single line header.

Note _____

This interface is only to be used by Kongsberg Maritime personnel.

- **C29 - TMS** For test purposes only

This cable is connected to the TMS Emulator slot for programming and development purposes. The signals of the TMS slot are available at a 14-pin double line header.

Note _____

This interface is only to be used by Kongsberg Maritime personnel.

7.3.1.4 Ethernet Switch Board – Gigabit

Figure 24 Ethernet Switch Board

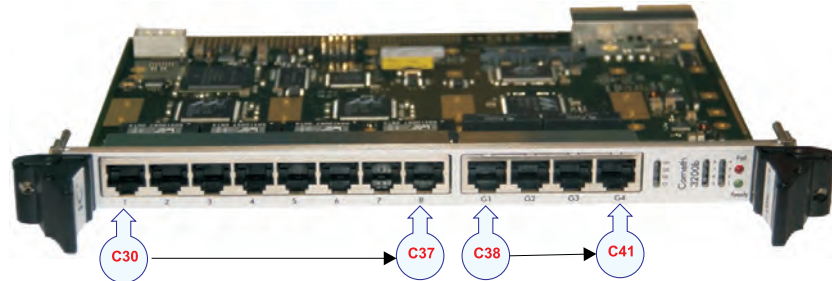

CD021098-006

- **C30 to C37 – 100 Megabit Ethernet ports**

The Ethernet cables are equipped with standard RJ-45 connectors. The Ethernet has 12 Ethernet ports. 8 fast ports * 10/100TX (FB) and 4 giga ports * 10/100/1000BT (FB)

The Ethernet interface of each RX32 receiver board and some of the TX36 transmitter boards are connected to fast ports from C30 to C37.

C31 to C34 – Here must RX32 be connected.

One Ethernet port must be used to communicate with the CPU board.

These cables are provided by the manufacturer. Each cable is cut to a suitable length for connection to dedicated ports. The cable ends are labelled accordingly.

For cable details see *Ethernet cable with RJ45* on page 142.

- **C38 to C41 – Giga ports**

The output data to the Raw data logger must be connected to port number C40.

C41 connects to next switch board.

These cables are provided by the manufacturer. Each cable is cut to a suitable length for connection to dedicated ports. The cable ends are labelled accordingly.

For cable details see *Ethernet cable with RJ45* on page 142.

7.3.1.5 Ethernet Switch Board – Megabit

Figure 25 Ethernet Switch Board with arrows

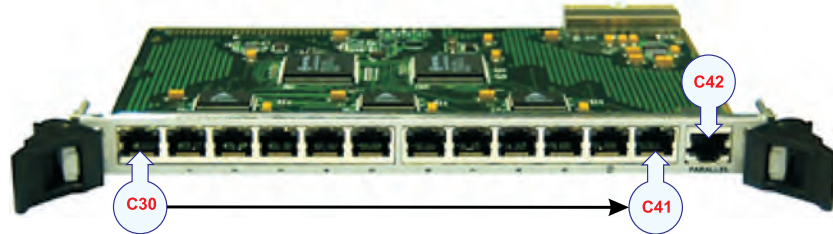

- **C30 to C41 - Ethernet ports**

The Ethernet cables are equipped with standard RJ-45 connectors. The Ethernet board has 12 Ethernet ports (0 to 11). The Ethernet interface on the TX36 transmitter boards must be connected to an Ethernet board.

These cables are provided by the manufacturer. Each cable is cut to a suitable length for connection to dedicated ports. The cable ends are labelled accordingly.

- **C42 - Parallel port – not used**

The parallel port has a standard Ethernet RJ-45 interface. This interface is not used.

7.3.1.6 Power Supply PSU 6V

Purpose and description

This is a 6 V / 25 A power supply. It is used to supply DC power to the analog part of the RX32 Receiver Boards.

Figure 26 Power Supply PSU 6V



External connections:

- None

7.3.1.7 RX32 receiver board

Figure 27 RX32 Receiver Board with arrows

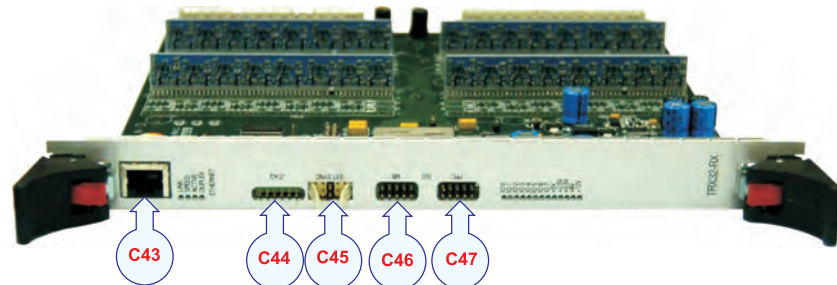

External connections

- **C43 - Connected to Ethernet switch board**

The Ethernet cable is equipped with a standard RJ-45 connector. The Ethernet interface of the RX32 receiver board must be connected to an Ethernet switch board. This interface is used for all command input and sample data output. This is normally the only cable connected to the RX32 receiver board. It is provided by the manufacturer. *Ethernet cable with RJ45* on page 142.

- **C44 - JTAG / For internal use only**

This cable is connected to the JTAG slot to provide a JTAG interface to the FPGA modules on the RX32 receiver board. The signals of the JTAG slot are available at a 6-pin single line header.

Note _____

This interface is only to be used by Kongsberg Maritime personnel.

- **C45 - External synchronization (EXT SYNC) / For internal use only**

This cable is connected to the EXT SYNC slot for accurate transmit synchronization with external equipment. The signals of the EXT SYNC slot are available at a 10-pin double line header.

Note _____

This interface is only to be used by Kongsberg Maritime personnel.

- **C46 - MicroBlaze (MB) / For internal use only**

This cable is connected to the MB slot for debugging the MicroBlaze (FPGA soft-core processor) program software. The signals of the MB slot are available at a 10-pin double line header.

Note _____

This interface is only to be used by Kongsberg Maritime personnel.

- **C47 - PowerPC (PPC) / For internal use only**

This cable is connected to the PPC slot for debugging the PowerPC (FPGA hard-core processor) program software. The signals of the PPC slot are available at a 10-pin double line header.

Note _____

This interface is only to be used by Kongsberg Maritime personnel.

7.3.1.8 TX36 transmitter board

Figure 28 TX36

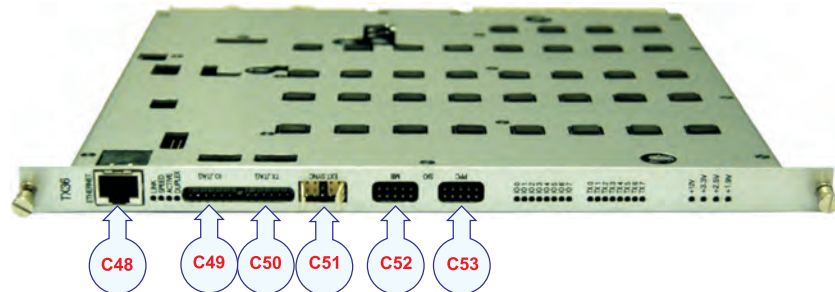

External connections

- **C48 - Connected to Ethernet switch board**

The Ethernet cable is equipped with a standard RJ-45 connector. The Ethernet interface of the TX36 transmitter board must be connected to an Ethernet switch board. This interface is used for all command input and sample data output. This is normally the only cable connected to the TX36 transmitter board. It is provided by the manufacturer.

For cable details see *Ethernet cable with RJ45* on page 142.

- **C49 - IO JTAG / For internal use only**

This cable is connected to the IO JTAG slot to provide a JTAG interface to the FPGA modules on the TX36 transmitter board. The signals of the IO JTAG slot are available at a 6-pin single line header.

Note _____

This interface is only to be used by Kongsberg Maritime personnel.

- **C50 - TX JTAG / For internal use only**

This cable is connected to the TX JTAG slot to provide a JTAG interface to the FPGA modules on the TX36 transmitter board. The signals of the TX JTAG slot are available at a 6-pin single line header.

Note _____

This interface is only to be used by Kongsberg Maritime personnel.

- **C51 - External synchronization / For internal use only**

This cable is connected to the EXT SYNC slot for accurate transmit synchronization with external equipment. The signals of the EXT SYNC slot are available at a 10-pin double line header.

Note _____

This interface is only to be used by Kongsberg Maritime personnel.

- **C52 - MicroBlaze (MB) / For internal use only**

This cable is connected to the MB slot for debugging the MicroBlaze (FPGA soft-core processor) program software. The signals of the MB slot are available at a 10-pin double line header.

Note _____

This interface is only to be used by Kongsberg Maritime personnel.

- **C53 - PowerPC (PPC) / For internal use only**

This cable is connected to the PPC slot for debugging the PowerPC (FPGA hard-core processor) program software. The signals of the PPC slot are available at a 10-pin double line header.

Note _____

This interface is only to be used by Kongsberg Maritime personnel.

7.3.1.9 Power Supply PSU 72V

Purpose and description

This is a 72 V / 5 A power supply. It is used to charge the capacitor battery located on the TX RIO boards.

Figure 29



External connections

- None

7.3.1.10 Power Supply PSU 12V

Purpose and description

This is a 12 V / 24 A power supply. It is used to supply DC power to the TX36 Transmitter Boards. It can also deliver 72 A extra during transmit (with maximum 10 % TX duty cycle).

Figure 30 Power Supply PSU 12V



External connections

- None

7.3.2 Transceiver Unit – rear view

Figure 31 Transceiver Unit rear view – 0.5 x 1 degree

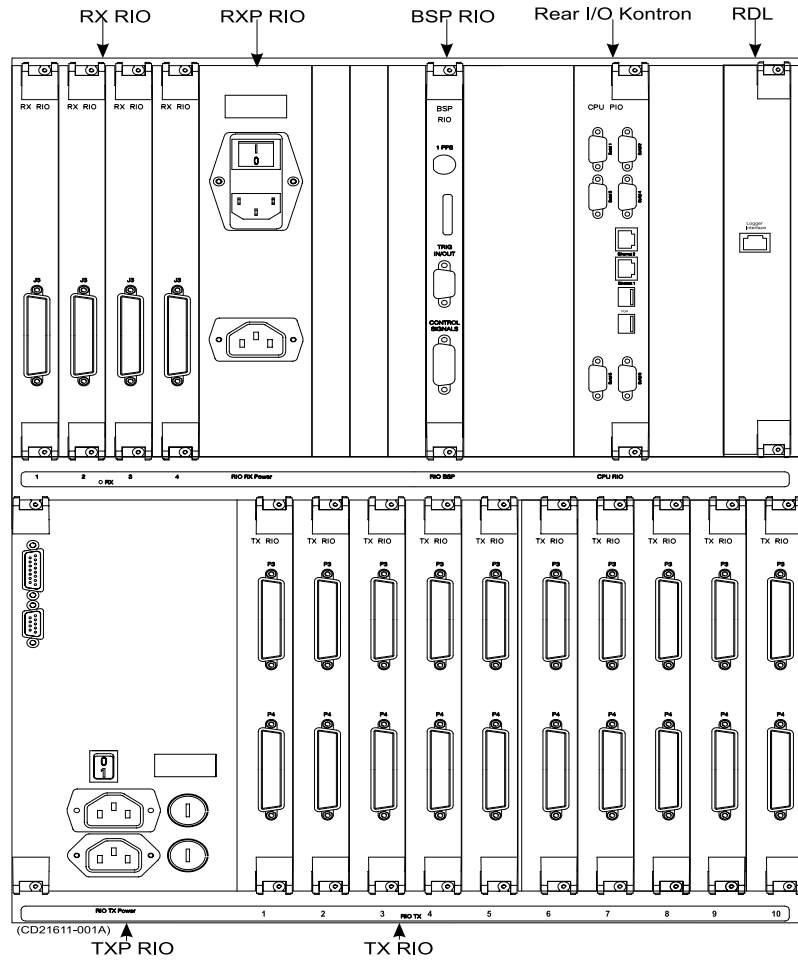

7.3.2.1 RX RIO – Rear Interface Board

Purpose and description

This is the rear I/O module for the RX32 Receiver Board. It holds transformers and band pass filters. It also connects the 32 receiver channels to the 78-pin connector. The signals are low level ac signals, $< 5\text{ V}$ and $< 0.1\text{ A}$.

Figure 32 RX RIO

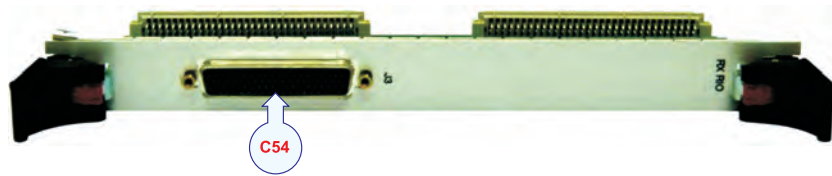

Facilities

LEDs

- None

External connections

- C54 - RX transducer

7.3.2.2 RXP RIO – Rear Interface Board

Figure 33 RXP RIO

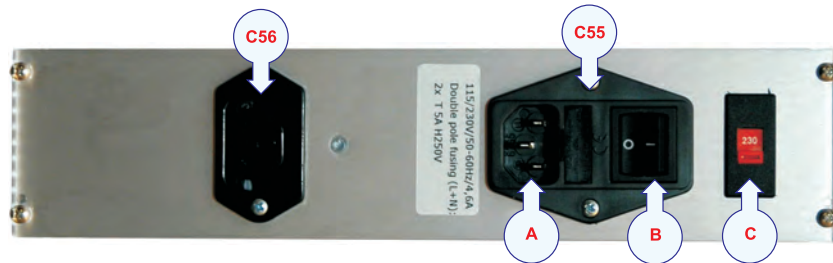

External connections

- **C55 – AC power**

A AC power

B Power On/off, normally set to on

C Switch – 115/230 V for the fan unit

This is a 115/230 Vac AC mains cable. Cable C55 is equipped with a 3-pin IEC female socket.

C55 connects to the TXP RIO board and the cable are provided by the manufacturer.

For cable details, see *Standard AC power cable* on page 141

- **C56 – AC power**

normally not used

7.3.2.3 BSP RIO – Rear Interface Board

Figure 34 BSP RIO



External connections

- **C57 - 1PPS**

This is a standard coaxial cable. It is used to provide a 1PPS timing signal.

on page

Generic coax cable on page 135

- **C58 - Trigger in/out**

This cable is equipped with a standard 9-pin D-sub connector.

The interface is used to synchronize the echo sounder's transmissions with other acoustic instruments.

This interface is normally not used (see cable C71).

Trigger in/out (not used) on page 138

- **C59 - Control signals**

This cable is equipped with a standard 15-pin D-sub connector and is connected to the TXP RIO board.

The interface is used to transmit internal synchronization signals and TX enable signals (time stamp of TX pulses).

This cable is provided by the manufacturer.

Internal control signals on page 139

7.3.2.4 Rear I/O Interface Board (Kontron)

Figure 35 I/O Interface Board

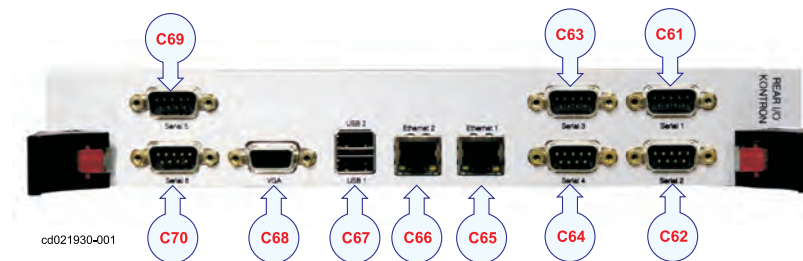

External connections

- **C61 / C64 - Serial lines 1 - 4, 9 pin D-sub, RS232**
 These cables are equipped with 9-pin connectors. These interfaces are used for connection to external sensors (position, attitude etc.).
 The serial lines are normally set up as follows
 - **Serial Port 1** - Positioning systems
 - **Serial Port 2** - Motion sensor
 - **Serial Port 3** - Auxiliary 1
 - **Serial Port 4** - Auxiliary 2
- **C65 / C66 - Ethernet, RJ45**
 - **C65** – **Ethernet 1** to operator station.
 - **C66** – **Ethernet 2** is a velocity input from motion sensor. This input is needed for doppler compensation in FM mode.
- **C67 - USB**
 The USB cable is equipped with a standard USB2 connector and it is only used for system testing by Kongsberg Maritime personnel.
- **C68 - VGA**
 This cable is equipped with a standard 15-pin D-sub connector. This interface is only used for system testing by Kongsberg Maritime personnel.
- **C69 / C70 - Serial lines 5 and 6, not used.**
 These cables are equipped with standard 9-pin D-sub connectors.

7.3.2.5 Raw data logger interface (RDL)

Purpose and description

This is a Gigabit Ethernet output for a raw data logger option. This “unit” is connected internally to the TRU GBit switch board.

Figure 36 RDL board



External connections

- **C85 - Ethernet**

Ethernet cable to an optional Raw data logger.

Ethernet cable with RJ45 on page 142

7.3.2.6 TXP RIO – Rear Interface Board

Figure 37 TXP RIO



Power switch

- **A - AC power switch** for the fan unit
- **B - On/off switch** – set to off if remote on/off control is used

WARNING

Set to off if remote control is used

External connections

- **C70 - Control signals**

This cable is equipped with a standard 15-pin D-sub connector and is connected to the BSP RIO board.

The interface is used for synchronization signals and TX enable signals (time stamp of TX pulses).

This cable is provided by the manufacturer.

Internal control signals on page 139

- **C71 - Remote On/Off control and synchronization**

This cable is equipped with a standard 9-pin D-sub connector.

The interface is used to connect to a remote On/Off power switch. It is also used for external trigger output and synchronization. For more information, see on page

Remote control and external trig on page 140

- **C72 / C73 - AC power**

These are 115/230 Vac AC mains cables. Cable C72 must be equipped with a 3-pin IEC male socket and C73 in a female equivalent.

C72 connects AC power to the RXP RIO board. C73 is connected to the ship's mains power.

The cable C72 is provided by the manufacturer.

Standard AC power cable on page 141

7.3.2.7 TX RIO – Rear Interface Board

Figure 38 TX RIO



External connections

- **C74 / C75 - TX transducer**

These are TX transducer cables terminated in 78-pin D-sub connectors. Each TX RIO board connects to two TX transducer cables.

7.3.3 Transceiver Unit – Cable configuration

This chapter presents a standard cable configuration for a complete EM 710 echo sounder system. The following illustrations describe a 0.5 x 1 degrees model, but note that the actual cable layout will be different for every system, depending on the EM 710 model, the number of external sensors and other interfacing systems.

Figure 39 0.5 x 1 degree system cabling between TRU and other system units and external systems

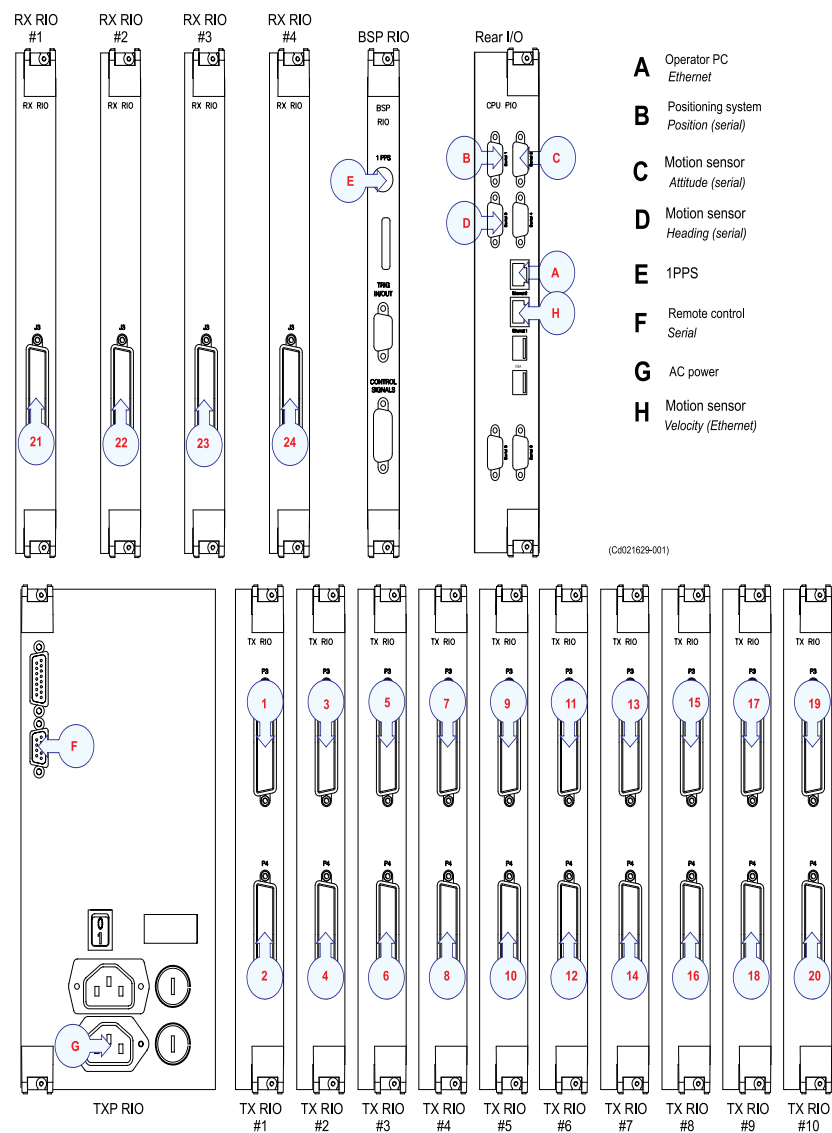

- 1 - 20 – Connection between TRU and TX array
- 21 - 24 – Connection between TRU and RX array

Figure 40 Internal cabling in the Transceiver Unit (power and control cables)

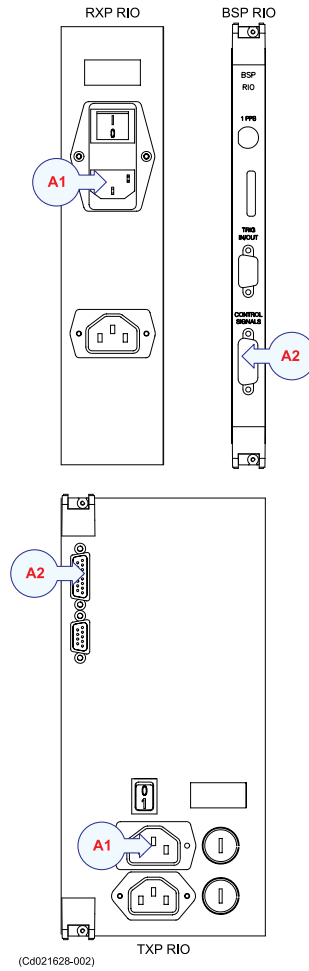

- **A1** – Connection between RXP RIO and TXP RIO (AC power)
- **A2** – Connection between BSP RIO and TXP RIO (control signals)

7.3.3.1 Cable clamp

In figure *TRU with cable clamp – rear view* on page 85 can you see the installed transceiver unit with a mounted cable clamp. This cable clamp unloads the tension on the transducer cables.

Figure 41 TRU with cable clamp – rear view

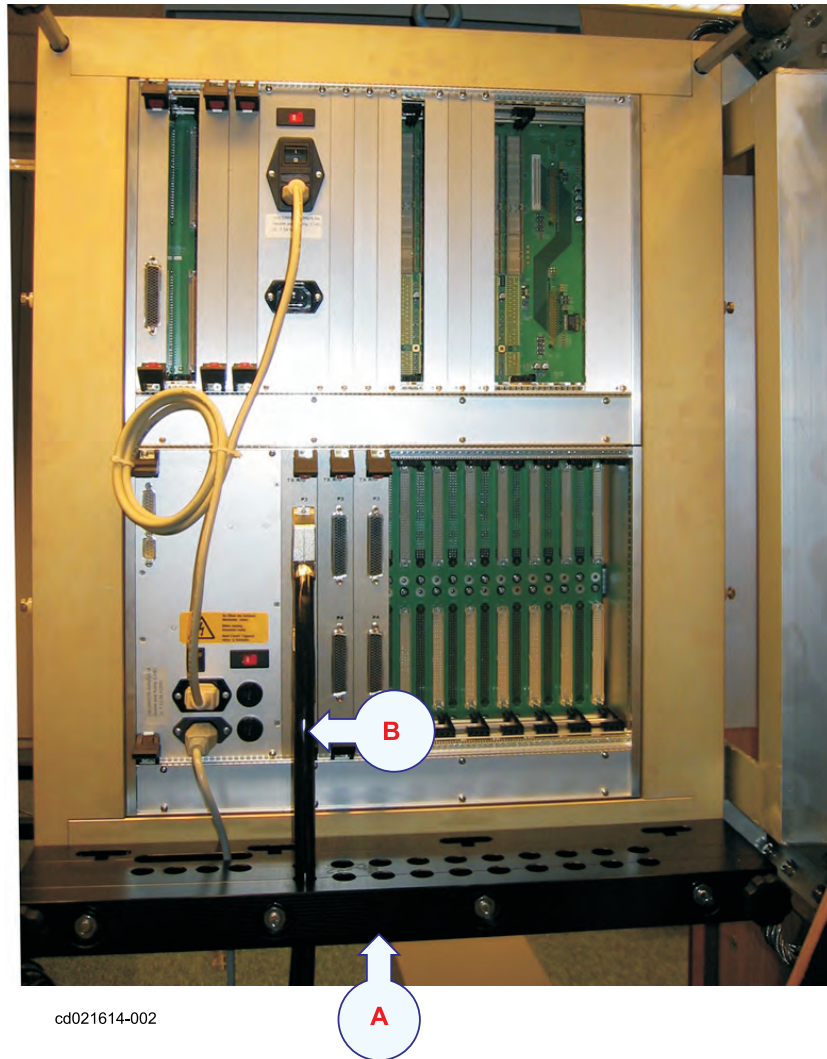

- A – cable clamp
- B – Transducer cable

Figure 42 Cable clamp

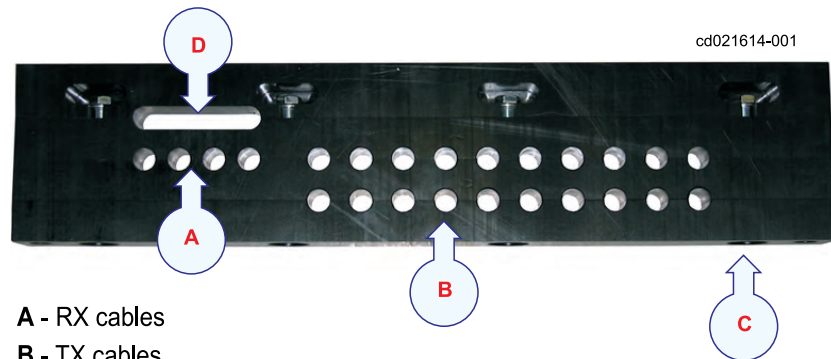

- A** - RX cables
- B** - TX cables
- C** - M10x100 Hex cap screw
with spring washer and 6k
locking nut (x4)
- D** - Other external cables
(power, serial lines, ethernet etc)

Transceiver Unit cable clamp on page 133

7.3.4 TRU compact – 2 x 2 degree system

Note

All cards used in 2 x 2 degree system are the same as shown in 0.5 x 1 degree system.

Figure 43 Transceiver Unit front view – 2 x 2 degree

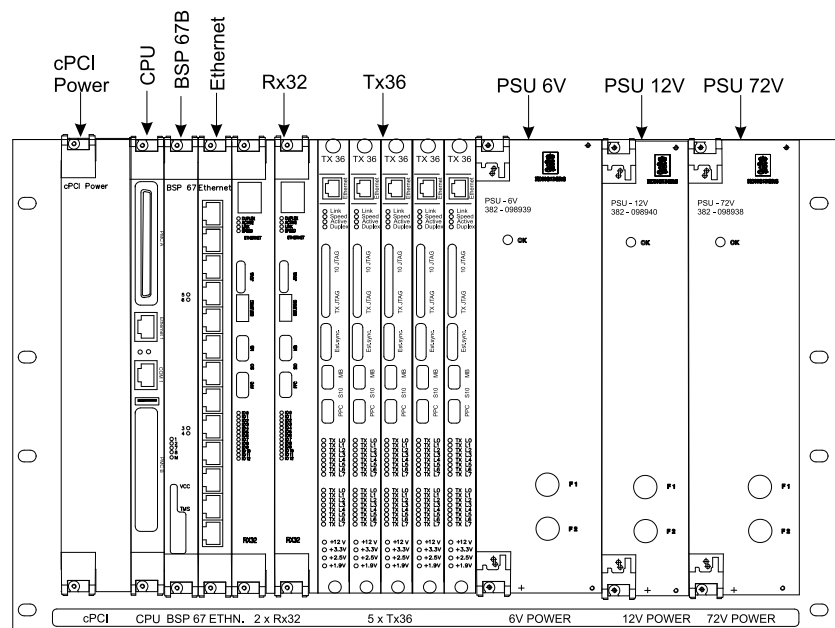

(05021661-001)

Pcb and power supply for 2 x 2 degree system – front view

- *cPCI Power Supply* on page 62
- *CPU Board with PMC Module* on page 63
- *BSP 67B Board* on page 64
- *Ethernet Switch Board – Megabit* on page 66
- *RX32 receiver board* on page 68
- *TX36 transmitter board* on page 70
- *Power Supply PSU 6V* on page 67
- *Power Supply PSU 12V* on page 73
- *Power Supply PSU 72V* on page 72

Figure 44 Transceiver Unit rear view – 2 x 2 degree

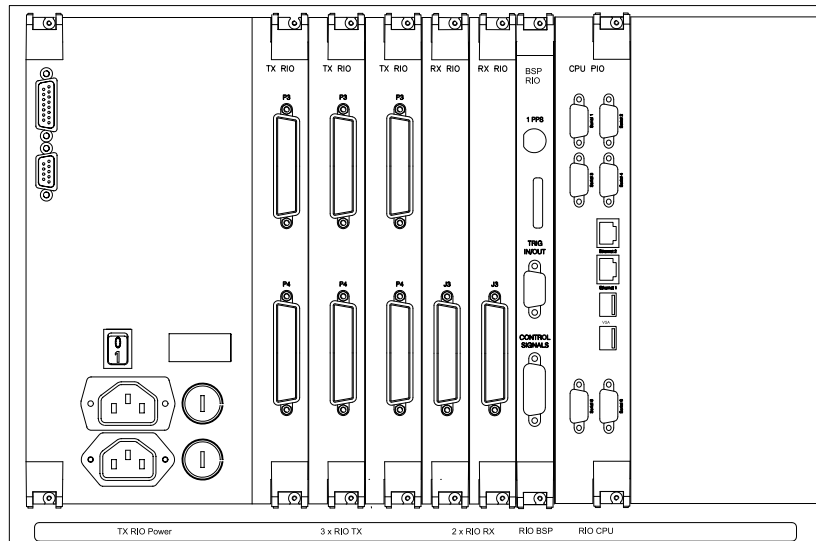

(CD021661-002)

Pcb and power supply for 2 x 2 degree system – rear view

- TXP RIO – Rear Interface Board on page 80
- TX RIO – Rear Interface Board on page 82
- RX RIO – Rear Interface Board on page 75
- BSP RIO – Rear Interface Board on page 77
- Rear I/O Interface Board (Kontron) on page 78

Figure 45 Cable configuration for 2 x 2 degrees system

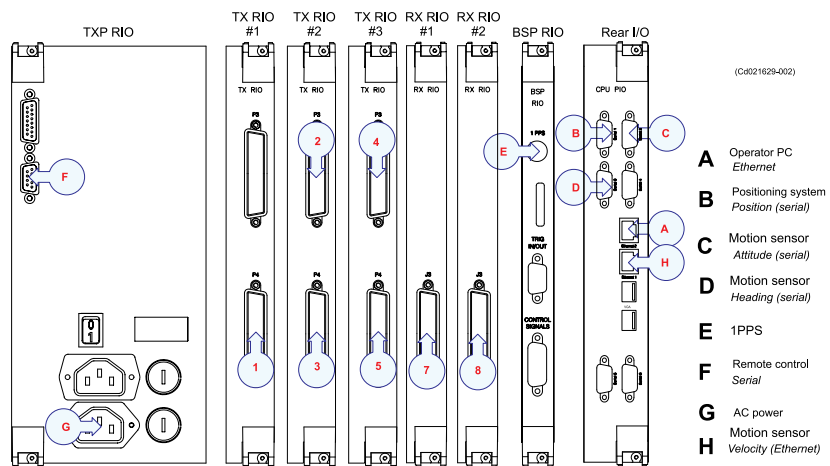

- 1 - 5 – Connection between TRU and TX array
- 7 - 8 – Connection between TRU and RX array

7.4 Transducer cables

The transducer cables between the transducer arrays and the Transceiver Unit are all supplied by Kongsberg Maritime with the EM 710 system. The physical number of cables depends on the chosen system beamwidth as shown the following tables.

System beamwidth (TX x RX)	Number and type of TX transducer modules	Number and type of RX transducer modules
	Number of cables from TX transducer array to Transceiver Unit	Number of cables from RX transducer array to Transceiver Unit
0.5 x 1 degree	2 x TX1	1 x RX1
	20	4
1 x 1 degree	1 x TX1	1 x RX1
	10	4
1 x 2 degrees	1 x TX1	1 x RX2
	10	2
2 x 2 degrees	1 x TX2	1 x RX2
	5	2

The following cable information is available both in the EM 710 installation and maintenance manuals. The cable markings are normally recorded in the installation manual first, and it is recommended to copy these records to the maintenance manual later.

Note that performance data about each element and its serial number are recorded in the Factory Acceptance Test documentation provided with each system.

7.4.1 Transmit array cable markings

The TX transducer module(s) and its cable is identified as follows:

TX1<m>/<n> or TX2<m>/<n> where <m> is the cable number (a number between 1 and 10) and <nnn> is the module's serial number (a numerical value).

The transducer cables are moulded to the TX array, but connect in the other end to the Transceiver Unit (TRU) with 76-pin D-sub connectors.

Note

During the installation of the TX array, you must fill in the cable identification table(s) below.

For a 0.5 x 1 degree system, you will need all cables listed in the tables. With a 1 x 1 or 1 x 2 degrees system, you only need the first 10, while the 2 x 2 degrees system only requires the first 5 cables.

The 0.5 x 1 degree system consists of two TX modules. It is essential to connect all 20 TX cables successively to the TX RIO boards in the Transceiver Unit. Where to start is determined by the physical orientation of the transducer cable outlet (port or starboard). Both options are shown in the figure below.

Figure 46 Connection of TX transducer cables, 0.5 x 1 degree system

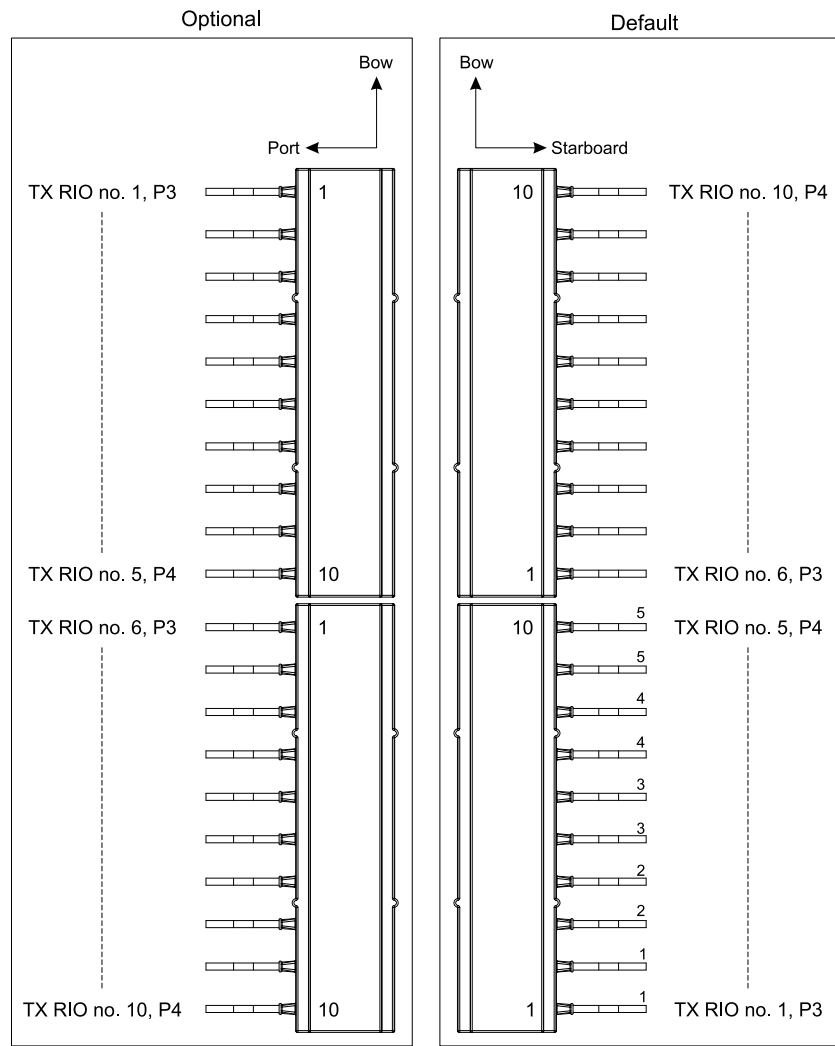

Table 5 Connection of TX transducer cables

TX array identification		TRU identification	
Cable no.	Serial no.	TX RIO no.	Socket no.
1		1	P3
2		1	P4
3		2	P3
4		2	P4
5		3	P3
6		3	P4
7		4	P3
8		4	P4
9		5	P3
10		5	P4

Table 6 Connection of TX transducer cables

TX array identification (second 0.5 degree array)		TRU identification	
Cable no.	Serial no.	TX RIO no.	Socket no.
1		6	P3
2		6	P4
3		7	P3
4		7	P4
5		8	P3
6		8	P4
7		9	P3
8		9	P4
9		10	P3
10		10	P4

Table 7 Connection of TX transducer cables with TRU compact – 2 x 2 degree system

TX array identification		TRU identification	
Cable no.	Serial no.	TX RIO no.	Socket no.
			P3
1		1	P4
2		2	P3
3		2	P4
4		3	P3
5		3	P4

7.4.2 Receive array cable markings

The RX transducer module(s) and its cable is identified as follows:

RX1<m>/<n> or **RX2<m>/<n>** where <m> is the cable number (a number between 1 and 10) and <n> is the module's serial number (a numerical value).

The transducer cables are moulded to the RX array, but connect in the other end to the Transceiver Unit (TRU) with 76-pin D-sub connectors.

Note _____

During the installation of the RX array, you must fill in the cable identification table below.

In a 0.5 x 1 or 1 x 1 degree system, you will need all cables listed in the table. With a 1 x 2 or 2 x 2 degrees system, you only need the first 2 cables.

RX array identification		TRU identification
Cable no.	Serial no.	RX RIO no.
1		1
2		2
3		3
4		4

7.5 Cable specifications

The Drawing file chapter provides detailed information about the cables used in the system. Note that several cables may share identical specifications.

The technical parameters provided for the cables are the minimum specifications. Also, in most cases, it may be useful to install extra pairs in selected cables for future expansions.

Note _____

The cables specified may not meet the standards provided by the vessel's classification society. Consult the applicable guidelines.

Kongsberg Maritime as takes no responsibility for performance degradation or damage caused to system, vessel or personnel if the cables used during installation do not meet these specifications.

7.6 Basic cabling requirements

All permanently installed cables associated with the system must be supported and protected along their entire lengths using conduits and/or cable trays. The only exception to this rule is over the final short distance (maximum 0.5 metre) as the cables run into the cabinets/units to which they are connected. These short service loops are to allow the cabinets to move on their shock mounts, and to allow maintenance and repair.

Cable trays

- Wherever possible, cable trays must be straight, accessible and placed so as to avoid possible contamination by condensation and dripping liquids (oil, etc.). They must be installed away from sources of heat, and must be protected against physical damage. Suitable shields must be provided where cables are installed in the vicinity of heat sources.
- Unless it is absolutely unavoidable, cables should not be installed across the vessel's expansion joints. If the situation is unavoidable, a loop of cable having a length proportional to the possible expansion of the joint must be provided. The minimum internal radius of the loop must be at least twelve times the external diameter of the cable.
- Where a service requires duplicate supply lines, the cables must follow separate paths through the vessel whenever possible.
- Signal cables must not be installed in the same cable tray or conduit as high-power cables.
- Cables containing insulation materials with different maximum-rated conductor temperatures should not be bunched together (that is, in a common clip, gland, conduit or duct). When this is impractical, the cables must be carefully arranged such that the maximum temperature expected in any cable in the group is within the specifications of the lowest-rated cable.
- Cables with protective coverings which may damage other cables should not be grouped with other cables.
- Cables having a copper sheath or braiding must be installed in such a way that galvanic corrosion by contact with other metals is prevented.
- To allow for future expansion of the system, all cables should be allocated spare conductor pairs. Also, space within the vessel should be set aside for the installation of extra cables.

Radio Frequency interference

All cables that are to be permanently installed within 9 m (30 ft) of any source of Radio Frequency (RF) interference such as a transmitter aerial system or radio transmitters, must, unless shielded by a metal deck or bulkhead, be adequately screened by sheathing, braiding or other suitable material. In such a situation flexible cables should be screened wherever possible.

It is important that cables, other than those supplying services to the equipment installed in a radio room, are not installed through a radio room, high power switch gear or other potential sources of interference. Cables which must pass through a radio room must be screened by a continuous metal conduit or trunking which must be bonded to the screening of the radio room at its points of entry and exit.

Physical protection

Cables exposed to the risk of physical damage must be enclosed in a steel conduit or protected by a metal casing unless the cable's covering (e.g. armour or sheath) is sufficient to protect it from the damage risk.

Cables exposed to an exceptional risk of mechanical damage (for example in holds, storage-spaces and cargo-spaces) must be protected by a suitable casing or conduit, even when armoured, if the cable covering does not guarantee sufficient protection for the cables.

Metallic materials used for the physical protection of cables must be suitably protected against corrosion.

Grounding

All metallic cable coverings (armour, metallic sheathing etc.) must be electrically connected to the vessel's hull at both ends except in the case of final sub-circuits where they should be connected at the supply end only.

Grounding connections should be made using a conductor which has a cross-sectional area appropriate for the current rating of the cable, or with a metal clamp which grips the metallic covering of the cable and is bonded to the hull of the vessel. These cable coverings may also be grounded by means of glands specially intended for this purpose and designed to ensure a good ground connection. The glands used must be firmly attached to, and in good electrical contact with, a metal structure grounded in accordance with these recommendations.

Electrical continuity must be ensured along the entire length of all cable coverings, particularly at joints and splices. In no case should the shielding of cables be used as the only means of grounding cables or units.

Metallic casings, pipes and conduits must be grounded, and when fitted with joints these must be mechanically and electrically grounded locally.

Cable connections

All cable connections are shown on the applicable cable plan and interconnection diagrams.

Where the cable plan shows cable connections outside an equipment box outline, the connections are to be made to a plug or socket which matches the plug or socket on that particular item of equipment.

Where two cables are connected in series via a junction box or terminal block, the screens of both cables must be connected together but not grounded.

Cable terminations

Care must be taken to ensure that the correct terminations are used for all cable conductors, especially those that are to be connected to terminal blocks. In this case, crimped sleeve-terminations must be fitted to prevent the conductor core from fraying and making a bad connection with the terminal block. It is also of the utmost importance that where crimped terminations are used, the correct size of crimp and crimping tool are used. In addition, each cable conductor must have a minimum of 15 cm slack (service loop) left before its termination is fitted.

Cable identification

Cable identification codes corresponding to the cable number shown in the cable plan must be attached to each of the external cables. These identification codes should be positioned on the cable in such a way that they are readily visible after all panels have been fitted. In addition, each cable conductor should be marked with the terminal board number or socket to which it is connected.

8 ALIGNMENT

Topics

- *Summary* on page 97
- *Vessel coordinate system* on page 98
- *Sensor location and alignment* on page 99
- *Transducer Measurements* on page 101
- *Calibration of system* on page 102

Figure 47 Reference points

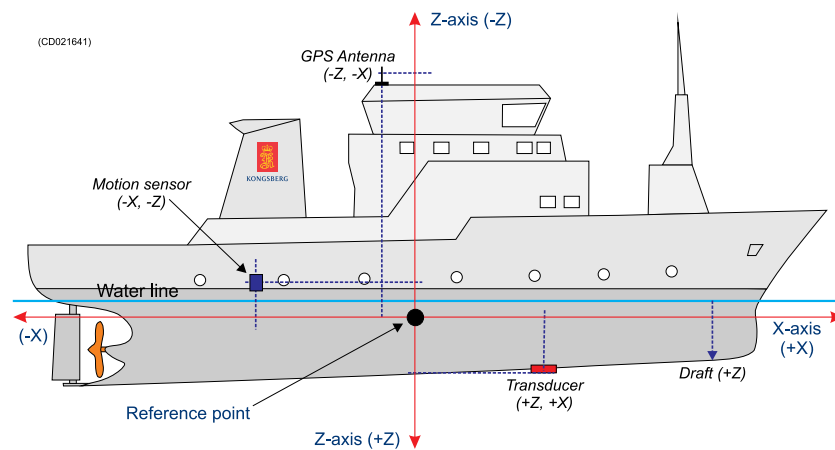

The EM 710 is a precision instrument for bathymetric swath mapping. To be able to produce data that are both detailed and correct, it is necessary to calibrate the survey vessel very well, and perhaps better than what may have been standard practice earlier.

The required measurement consists of:

- measurement of where sensors and transducers are located
- measurement of how sensors and transducers are oriented
- measurement of the water line vertical location
- alignment of angular measurement sensors

After the installation is completed in dock, a full set of measurements must be carried out to determine the relative alignment of the sensors. This job has to be done by professional and experienced land surveyors with qualified work instructions for this type of work. Kongsberg Maritime can not be expected to have qualified personnel for such work.

The results, with all sensor locations and alignments referred to a common vessel coordinate system, are to be entered in the EM 710 Operator Station.

NB! Some external sensors may have been set up to output data referred to a location that differ from where it is physically mounted. It is the x, y, z values for this location that must be entered into the EM 710 Operator station.

8.1 Summary

The minimum requirements for alignment accuracy are given for the various sensors in the following tables

WARNING

System performance will be reduced if the requirements are not fulfilled. The calibration value should not exceed the measurement accuracies stated below.

TX array	Measurement accuracy
Position (x, y) [m]	± 0.05
Position (z) [m]	± 0.02
Pitch [deg]	± 0.05
Roll [deg]	± 0.20
Heading [deg]	± 0.10

RX array	Measurement accuracy
Position (x, y) [m]	± 0.05
Position (z) [m]	± 0.02
Pitch [deg]	± 0.20
Roll [deg]	± 0.02
Heading [deg]	± 0.10

Motion sensor	Measurement accuracy
Position (x, y) [m]	± 0.05
Position (z) [m]	± 0.05
Pitch [deg]	± 0.05
Roll [deg]	± 0.02
Heading [deg]	± 0.10

Heading sensor	Measurement accuracy
Heading [deg]	± 0.10

Positioning system (antenna)	Measurement accuracy
Position (x, y) [m]	± 0.05
Position (z) [m]	± 0.02

Water line	Measurement accuracy
Position (z) [m]	± 0.02

Note

The given accuracies in the tables in this chapter, are maximum values, and if easily achievable, better accuracies should be obtained.

The relative heading accuracy between Rx and Tx must be within $\pm 0.05^\circ$.

All distance measurements are to be done to an accuracy of 5 cm both horizontally and vertically. (2 cm for transducers or better)

The procedures and requirements made by the manufacturers of the external sensors connected to the EM 710 must also be taken into account.

8.2 Vessel coordinate system

A Cartesian coordinate system must be defined for the vessel. The following definition must be adhered to:

- X = forwards
- Y = to starboard
- Z = pointing downwards

There is no restriction on where the coordinate system's origo is located.

Note

The sea surface with the vessel in normal trim defines the horizontal (X-Y) plane. The water line should therefore be marked on the hull with the vessel in normal trim before dry docking for installation of transducers.

Figure 48 Reference points

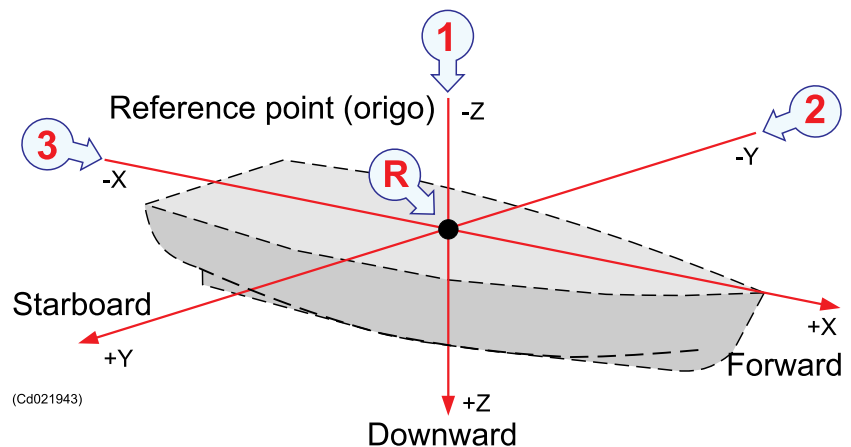

Reference points must be established on the vessel at selected positions. These are needed during measurements of the sensor positions. Visual markings at these positions should be prepared and noted on the vessel drawings with XYZ coordinates in the vessel coordinate system.

8.3 Sensor location and alignment

- *Motion sensor* on page 99
- *Heading sensor* on page 100
- *Positioning system* on page 100
- *Water line* on page 100

8.3.1 Motion sensor

The system motion sensor is to provide the multibeam echo sounder with the angular orientation of the vessel coordinate system with respect to the gravity vector i.e. roll and pitch (usually the motion sensor also provides heave and sometimes heading). The motion sensor must thus know how it is oriented physically with respect to the vessel coordinate system. The motion sensor installation manual should be followed with respect to how this is to be achieved. If the sensor has input fields for how it is mounted, and the measurement of its orientation is feasible with an acceptable accuracy and effort, it is recommended that this done at the same time as the orientation measurements of the transducers is done. The final accuracy of the alignment of the sensor should in any case be evaluated and confirmed by examining the sensor measurement values when the vessel is in drydock with a known and accurately determined orientation. A calibration survey should afterwards be performed at sea to confirm correct performance.

The motion sensor must have a specified accuracy in roll and pitch of 0.02° or better. Any orientations measurements should be performed to this accuracy, as must the evaluation of the measurement data of the sensor. (Note that the most critical parameter is roll and a pitch accuracy of 0.05° is acceptable.)

The motion sensor must be aligned with the vessel centre line to an accuracy of 0.1° to avoid that crosscoupling between roll and pitch measurements degrades the accuracy.

The motion sensor should normally be mounted on the centre line of the vessel, either close of the multibeam transducers or close to the vessel's CG (Centre of Gravity).

The latter point is recommended if the sensor is used for other purposes than just the multibeam, or if its accuracy is sensitive to horizontal acceleration.

If there is any point in the fore-aft direction which does not change height with respect to the water line with changes in vessel speed, this will be the ideal location for the motion sensor as it will eliminate any errors from squat induced height changes which is not measured by current motion sensors.

8.3.2 Heading sensor

This sensor can either be based upon:

- GPS measurements like Seapath 200 or POS/MV
- Fibre optic gyro compass
- Standard gyro compass

The heading sensor dynamic accuracy should be in the order of one third of the transmit transducer beamwidth or better (i.e. 0.3° for a 1° beamwidth).

The sensor must be aligned to the vessel centre line to provide an accuracy better than a fifth of the transmit transducer beamwidth (i.e. 0.2° for a 1° beamwidth).

Compasses sensitive to acceleration should be mounted close to CG (Centre of Gravity)

Please see the sensor installation manual for any further instructions on installation and alignment.

The output of the sensor must be verified with the vessel having a known heading such as when it is in drydock. Alignment accuracy can also be evaluated with the vessel tied (in opposite directions) along a quay with known heading. A calibration survey should afterwards be performed at sea to confirm correct performance.

8.3.3 Positioning system

Most positioning systems are today based on Global Navigation Satellite System technology (GNSS) such as GPS, GLONASS and/or (later) GALILEO. The location of the positioning system, antenna must be measured, including its height (if geoid height is a measured and used parameter). It should be noted that some GNSS based systems use two (or more) antennas to provide vessel heading, if so the installation manual for the system should be consulted for how these antennae are to be aligned and how accurately the location of the antennae need to be measured.

8.3.4 Water line

With the vessel in normal trim, i.e with an indicated pitch angle of zero from the motion sensor, the distance to the waterline may be measured anywhere on the vessel. Otherwise it must be measured at the alongship physical location of the motion sensor.

The measurement should be taken on both sides of the vessel and averaged to remove any roll effects. Simultaneous measurements are required if the vessel is moving.

8.4 Transducer Measurements

It may be most practical to perform these measurements on the transducer mounting frames before installation of the transducer modules. A final verification after module installation is then required.

Note that it is also necessary to ensure that the final transducer array face is flat with a maximum deviation from flatness of ± 0.2 mm peak to peak including any rotation.

8.4.1 Transducer heading

The heading of the transducers is measured as the average heading of the two fore-and-aft oriented sides of each transducer arrays. Thus, the heading of the transmit transducer is the heading along the keel, while the heading of the receiver array is the heading across the keel. For the receive transducer it may be better to measure the heading along the keel, and then subtract 90° to achieve the correct value. The measurement accuracy is required to be within one fifth of the beamwidth of the transmit transducer.

Note however that the measurement accuracy of the relative heading between the transmit and receive transducers must be better than 0.05° .

8.4.2 Transducer roll and pitch

Roll and pitch measurements are made according to standard conventions with positive pitch angle if the transmitter array's forward end is above the aft end (tilts up), and positive roll if the starboard side of the receiver array is lower than the port side.

Note that the roll and pitch angles to be measured are relative to the horizontal plane as defined by the vessel's coordinate system. I.e. for roll the angle that the transducer's y-axis have with respect to the horizontal and for pitch the angle that the transducers x-axis have with respect to the horizontal plane. The multibeam echo sounder converts the measured angles as entered into the installation menu to rotation angles before use i.e. do not do such a conversion before entering them into the system.

The required measurement accuracy is given in the table below.

Table 8 Transducer roll and pitch

	Transmit transducer	Receive transducer
Roll	0.2°	0.02°
Pitch	0.05°	0.2°

8.4.3 Transducer position

The location of the centre of each transducer array face must be measured in the vessel coordinate system. This centre must be measured relative to the system reference point. Measurements must be done in the X, Y and Z directions on both transducers.

8.4.4 System calibration after final alignment

During the sea trials (SAT), calibration surveys are required as described in the EM 710 Operator Manual. Based on the calibration parameters determined from these surveys, together with the measurements done in the dry-dock, proper values are entered into the EM 710.

It is advisable to perform a calibration survey at regular intervals or prior to any large survey to check the performance of the sensors. If any sensor has been replaced or another navigation antenna is installed etc, a new calibration is required.

8.5 Calibration of system

The calibration of the system will be done during a sea trial. This procedure are described in the SIS operator manual.

9 SYSTEM TEST

Topics

- *Visual inspection of units* on page 104
- *Electrical checks* on page 106
- *Final installation checks* on page 107

After the installation has been performed and before the EM 710 system is brought into operation for the first time, a series of test procedures must be carried out to confirm a correct installation.

Some of the tests can be carried out on individual units once that particular unit has been installed. However, in the interests of safety and to avoid possible mistakes, it is recommended to set aside a period of time at the end of the installation phase specifically for the checks and tests. The entire set of tests can then be performed in sequence to ensure the entire system is comprehensively checked.

Note

If the test engineer is not satisfied with the quality of any part of the installation, he/she must contact the customer to have the work rectified and brought up to the required quality standards.

Which specific tests that are to be conducted are normally specified in the contract. In most cases, the following tests are performed

- Installation tests
 - These tests are performed during the installation work. The general procedures are given in this chapter. These tests take place before power is applied to the system.
- Setting To Work (STW)
 - This work is performed by the installation personnel from Kongsberg Maritime. All specific hardware and software units are checked, and the cabling is controlled.
- Harbour Acceptance Test (HAT)
 - This test is performed by the installation personnel from Kongsberg Maritime together with representatives from the customer and in some cases the installation shipyard.
- Sea Acceptance Test (SAT)
 - This test takes place with the vessel in open sea. It is performed by the installation personnel from Kongsberg Maritime together with representatives from the customer and in some cases the installation shipyard. The purpose of the test is to check the functional specifications of the system during normal working conditions.

9.1 Visual inspection of units

9.1.1 Scope

WARNING _____

These checks must be completed before any power is switched onto the system.

After the physical installation has been carried out, all the system units must be visually checked to ensure that the EM 710 units have been installed correctly. You must ensure that the units have been mounted in the correct locations, correctly orientated (e.g. the right way up) and are correctly secured.

9.1.2 Operator Unit

Perform a close visual inspection of the unit according to the following procedure

- 1 Check that the unit is installed properly, secured, and that it is suitably orientated to enable easy operation.
- 2 Check that the unit is not damaged.
- 3 Make sure that appropriate slack has been applied to the cables.
- 4 Check that the air vents are not blocked.
- 5 Check the immediate environment around the unit. The operator should have easy access to a communication system, and it must be possible to dim and/or switch off the deckhead lights.
- 6 Checked (date/sign): _____

9.1.3 Transceiver Unit

Perform a close visual inspection of the EM 710 Transceiver Unit cabinet.

- 1 Check that the unit is installed in the correct location, and is suitably orientated to enable easy maintenance.
- 2 Check that the proper mounting bolts have been used, and that proper torque has been applied.
- 3 Check that the unit is not damaged.
- 4 Make sure that you have access to the internal part of the cabinet, from both sides, and that appropriate slack has been applied to the cables.
- 5 Check that the air vents are not blocked.
- 6 Check that the sonar room is equipped with proper light for maintenance work.
- 7 Check that the sonar room is equipped with the ventilation facilities required for continuous operation.
- 8 Checked
(date/sign): _____

9.2 Electrical checks

9.2.1 Scope

This section of the manual contains the test procedures for the EM 710 system's power and signal interface cables.

WARNING

These checks must be completed before any power is switched onto the system.

9.2.2 Cabling

Visual cable inspection

Refer to the cable plans and interconnection diagrams, and check all power and interconnection cables. Any locally fitted plugs and connectors should also be checked to ensure that the correct types have been used for the specific locations. (Sealed or spark-proof connectors in areas where flammable gasses may accumulate, etc.)

Ensure that all cable connections have been made according to the cable plan, and that all connections are tight and secure. Ensure that all cables are correctly laid in conduits, or are otherwise protected according to the regulations and recommendations laid down by the vessel's registering authority. Ensure all protective covers are fastened correctly.

Cable connections and continuity

After the cable connections have been completed and the visual inspection has been carried out, all the cable cores must be checked for correct connection and continuity. Refer to the cable plans and interconnection diagrams, and check all interconnection cables. Any locally fitted plugs and connectors must be checked for shorts or open circuits. Ensure all cable connections have been made according to the cable plan, and that all connections are tight and secure.

The check procedure will require two engineers equipped with two-way communication devices; one will require continuity test equipment, while the other will require a suitable shorting strap.

Follow the check procedure below for each cable core

- 1 Position yourselves one at each end of the cable to be checked. Good communications must be established between you and your assistant.
- 2 Ensure that the cable to be tested is not connected to any power source.

- If a cable terminates in a plug at the unit, the test will be more easily conducted if the plug is disconnected.
- 3 Select one pair of cable cores, and check that the cores are connected to the correct terminals in the unit.
 - 4 Connect your continuity tester to the two terminals in question and check the continuity.
 - If a low resistance exists between the two cores, this may indicate the cores are connected to circuits or units with low internal resistance. If this is the case, disconnect the cores from the terminal block and test again.
 - The resistance should be nearing ∞ ohms.
 - 5 Tell your assistant to short the two cores together. Repeat the previous test.
 - The resistance should be 0 (zero) ohms.
 - 6 Tell your assistant to remove the shorting strap.
 - Check that the resistance reaches ∞ ohms again.
 - 7 Check each core's resistance to ground, and each core's resistance to all the other cores in the cable.
 - All results should be close to ∞ ohms.
 - 8 Assuming the test results are correct, the cores must be reconnected to the terminal block (if they had been removed), and the terminals checked to ensure they are tight.
 - 9 On completion, move on to the next pair of cores and repeat the tests until the entire cable has been checked.

9.2.3 Operational voltages

Check that the operational voltages on the equipment match the power available on the vessel.

9.3 Final installation checks

After installation - but before un-docking - a number of verification must be done to check that the mechanical and electrical installation has been performed correctly.

Procedure

- 1 Check that the measured positions of the transducers, motion sensor and positioning system antenna are reasonable by comparing them with those estimated from the vessel drawings.
- 2 Check that the measured installation angles of the transducers is reasonable by comparing them with measurements done with a simple inclinometer.

- 3 Check that the specified sacrificial anodes have been mounted, and that any specified anti-fouling paint has been applied correctly.
- 4 Check that all system units have been fastened properly and that all nuts and bolts have been tightened properly.
- 5 Check that the data from the motion sensor, the heading sensor and the positioning system are correctly read by the EM 710 and that the values are reasonable before un-docking.

The steps in this procedure may be incorporated in the “Harbour Acceptance Test” carried out as a final check to test both the installation and the main functions of the system.

10 INSTALLATION DRAWINGS

This chapter contains installation drawings and cable details.

If required, certain drawings may be supplied on AutoCad or PDF format. To order, contact Kongsberg Maritime and refer to the drawing number in the bottom right corner of the frame.

Installation drawings

- *0.5° mounting frame assembly TX module* on page 110
- *1° mounting frame assembly RX module* on page 112
- *2° mounting frame assembly TX/RX module* on page 114
- *0.5 x 1° gondola* on page 116
- *Transducer TX1 Outline dimensions* on page 118
- *Transducer TX2 Outline dimensions* on page 120
- *Transducer RX1 Outline dimensions* on page 122
- *Transducer RX2 Outline dimensions* on page 124
- *HWS Operator Station Outline dimensions* on page 126
- *Transceiver Unit Outline dimensions* on page 127
- *Transceiver Unit 2 x 2 degree system – Outline dimensions* on page 129
- *Transceiver Unit mounting bracket* on page 131
- *Junction Box – outline dimensions* on page 132
- *Transceiver Unit cable clamp* on page 133

Cable details

- *Generic RS-232 Serial line* on page 134
- *Generic coax cable* on page 135
- *Sound speed probe interface* on page 136
- *RS-232 or RS-422/485 serial line* on page 137
- *Remote control and external trig* on page 140
- *Standard AC power cable* on page 141
- *Ethernet cable with RJ45* on page 142
- *VGA/SVGA Display cable* on page 143
- *USB cable* on page 144
- *Keyboard cable* on page 145
- *Mouse cable* on page 146
- *Parallel printer* on page 147
- *RX/TX transducer cables* on page 148

10.1 Installation Drawings

10.1.1 0.5° mounting frame assembly TX module

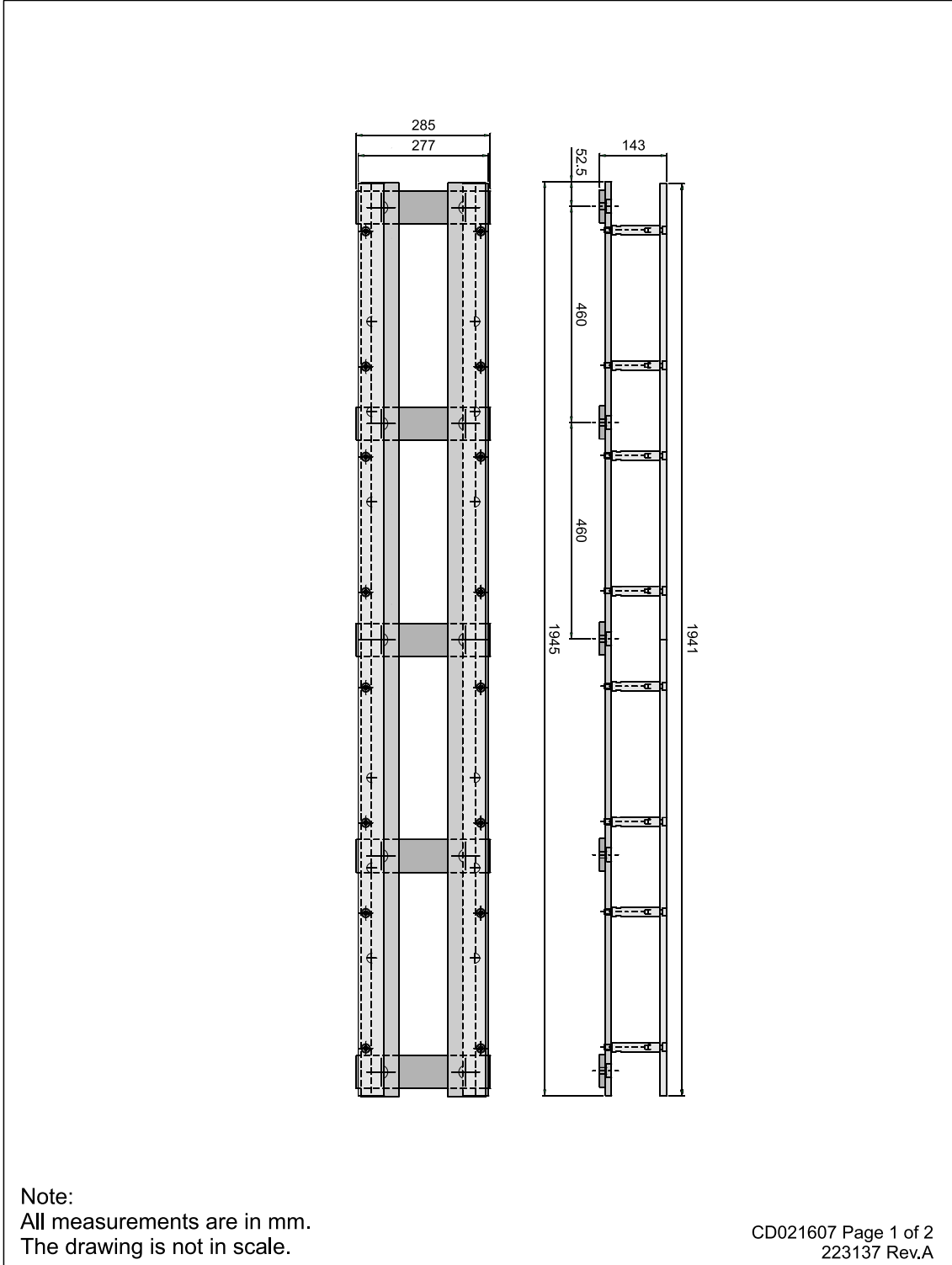

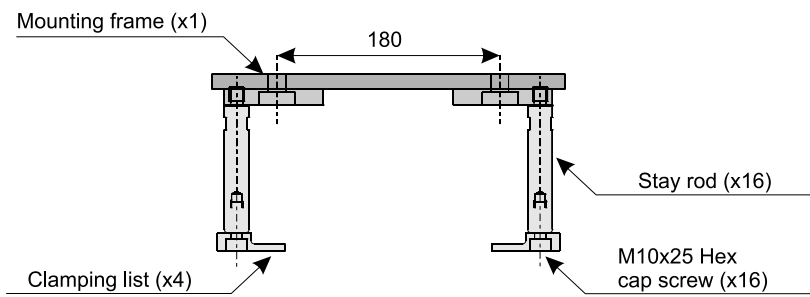

Note:
All measurements are in mm.
The drawing is not in scale.

Cd021607 Page 2 of 2
223137 Rev.A

10.1.2 1° mounting frame assembly RX module

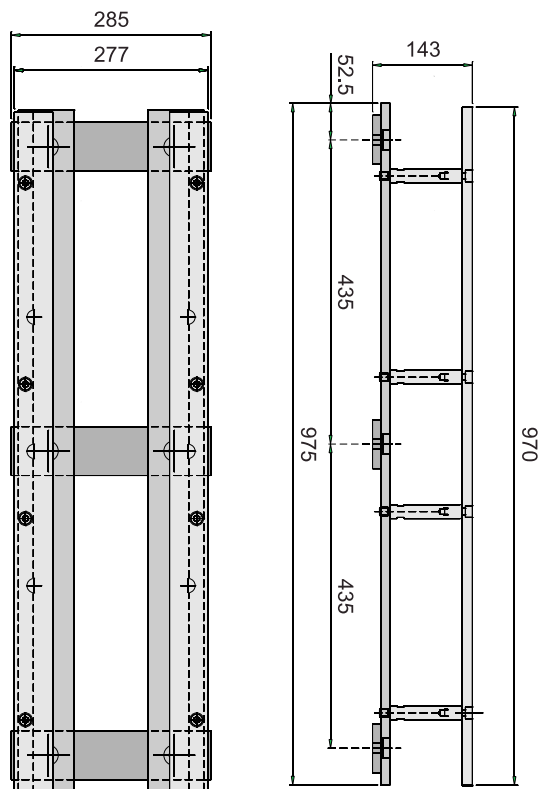

Note:
All measurements are in mm.
The drawing is not in scale.

Cd021608 Page 1 of 2
223139 Rev.B

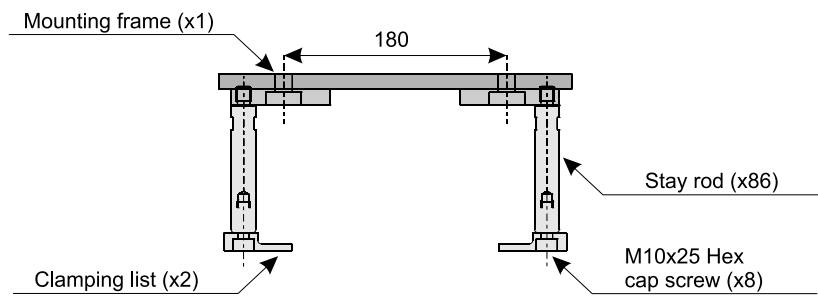

Note:
All measurements are in mm.
The drawing is not in scale.

Cd021608 Page 2 of 2
223139 Rev.B

10.1.3 2° mounting frame assembly TX/RX module

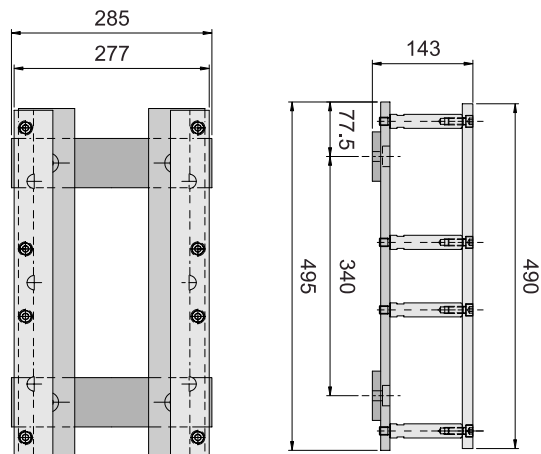

Note:
All measurements are in mm.
The drawing is not in scale.

CD021612 Page 1 of 2
223273 Rev.B

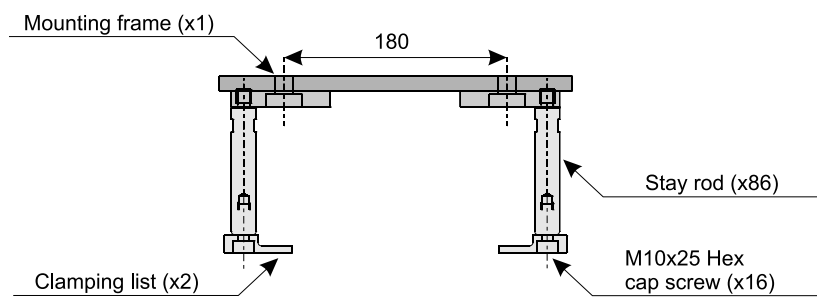

Note:
All measurements are in mm.
The drawing is not in scale.

CD021612 Page 2 of 2
223273 Rev.B

10.1.4 0.5 x 1° gondola

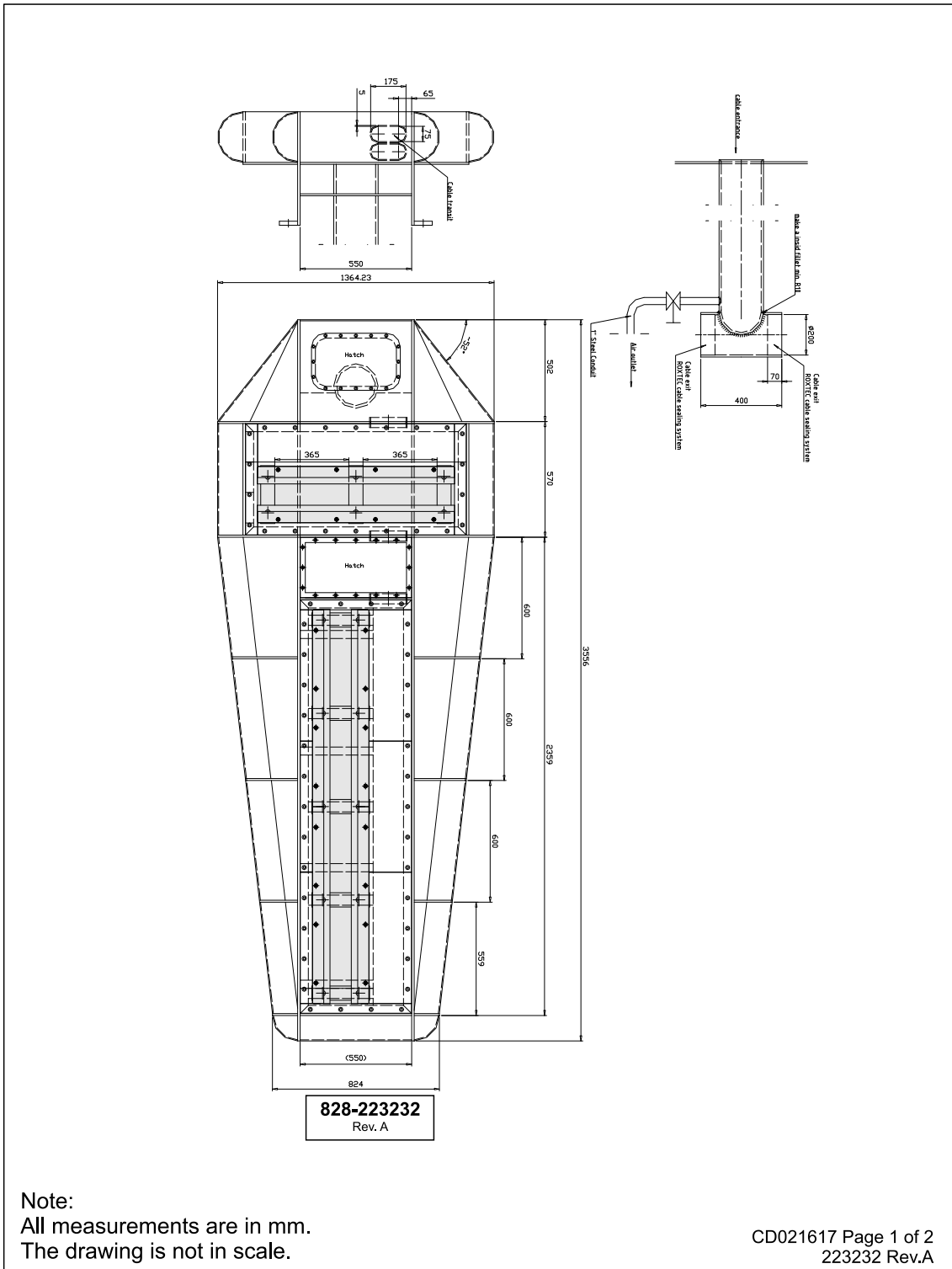

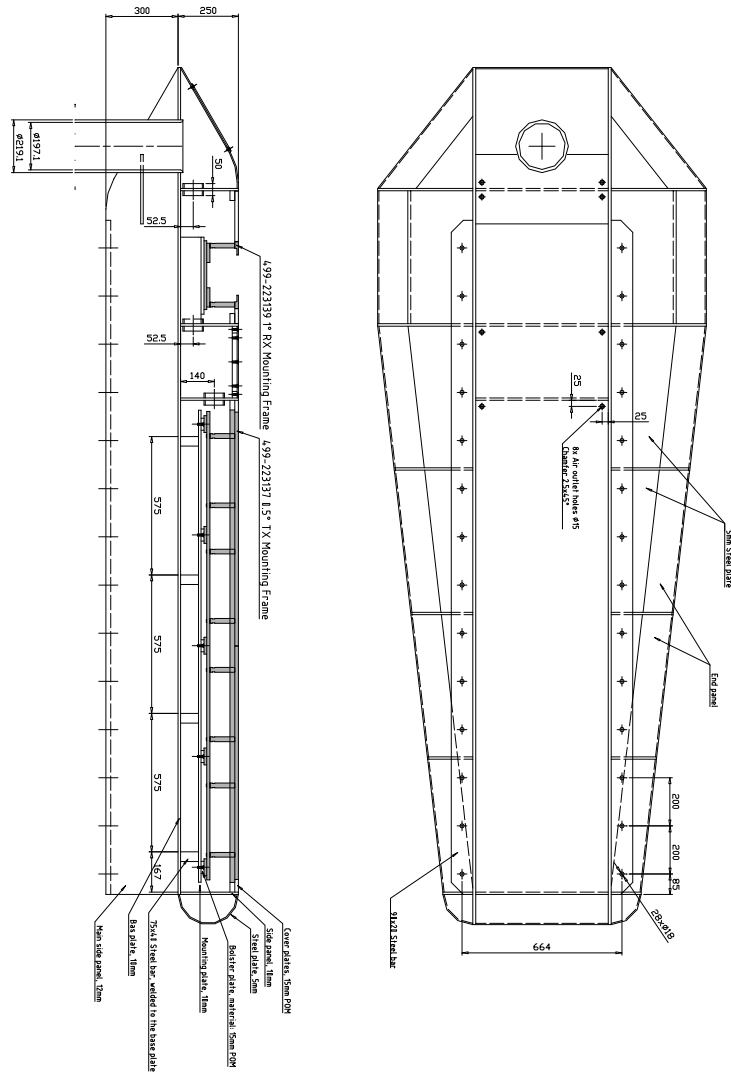

Note:
 All measurements are in mm.
 The drawing is not in scale.

Cd021617 Page 2 of 2
 223232 Rev.A

10.1.5 Transducer TX1 Outline dimensions

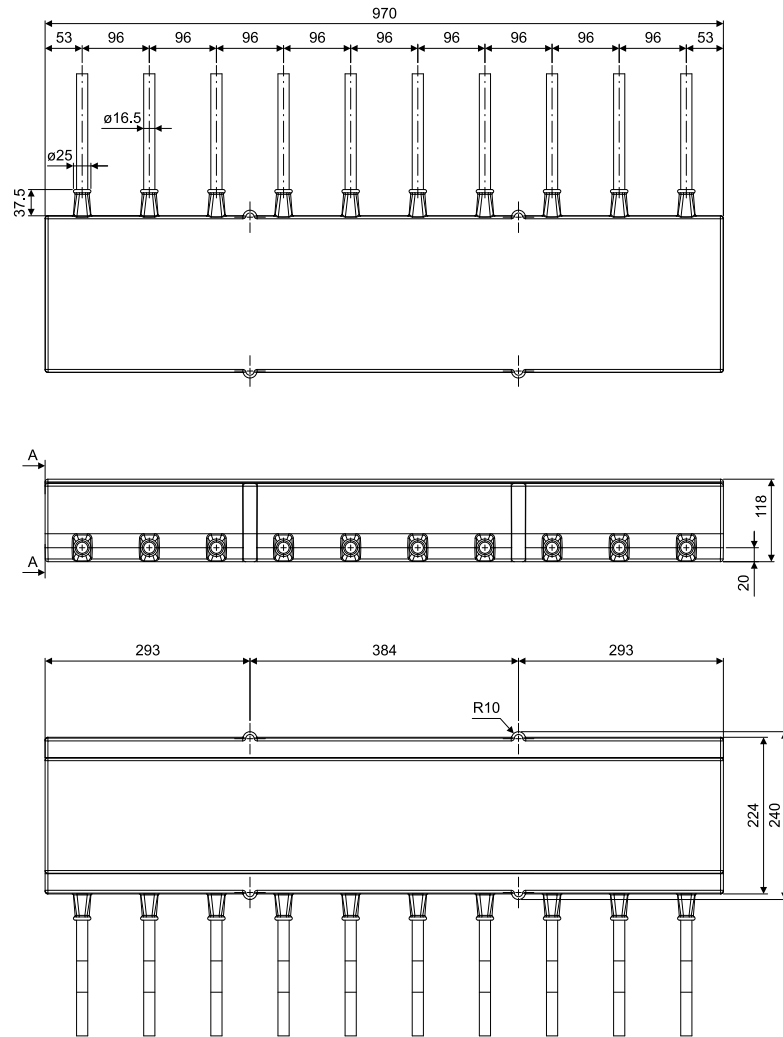

Transducer registration no. and serial no. are indicated on the cables.
Standard cable length = 15 m.

Note:
All measurements are in mm.
The drawing is not in scale.

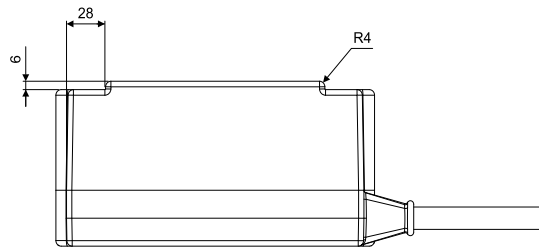

Section A-A

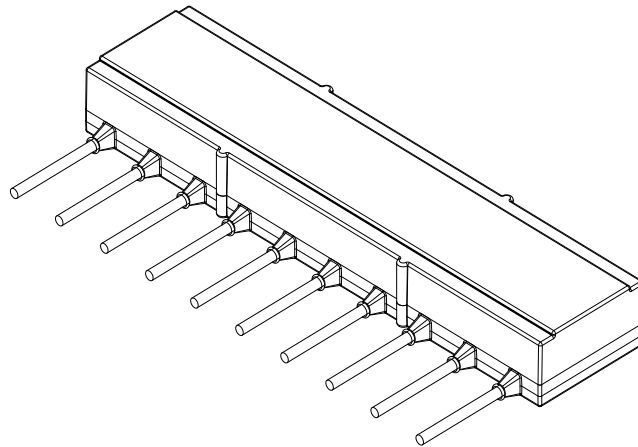

Note:
All measurements are in mm.
The drawing is not in scale.

Cd021603 Page 2 of 2
216148 Rev.A

10.1.6 Transducer TX2 Outline dimensions

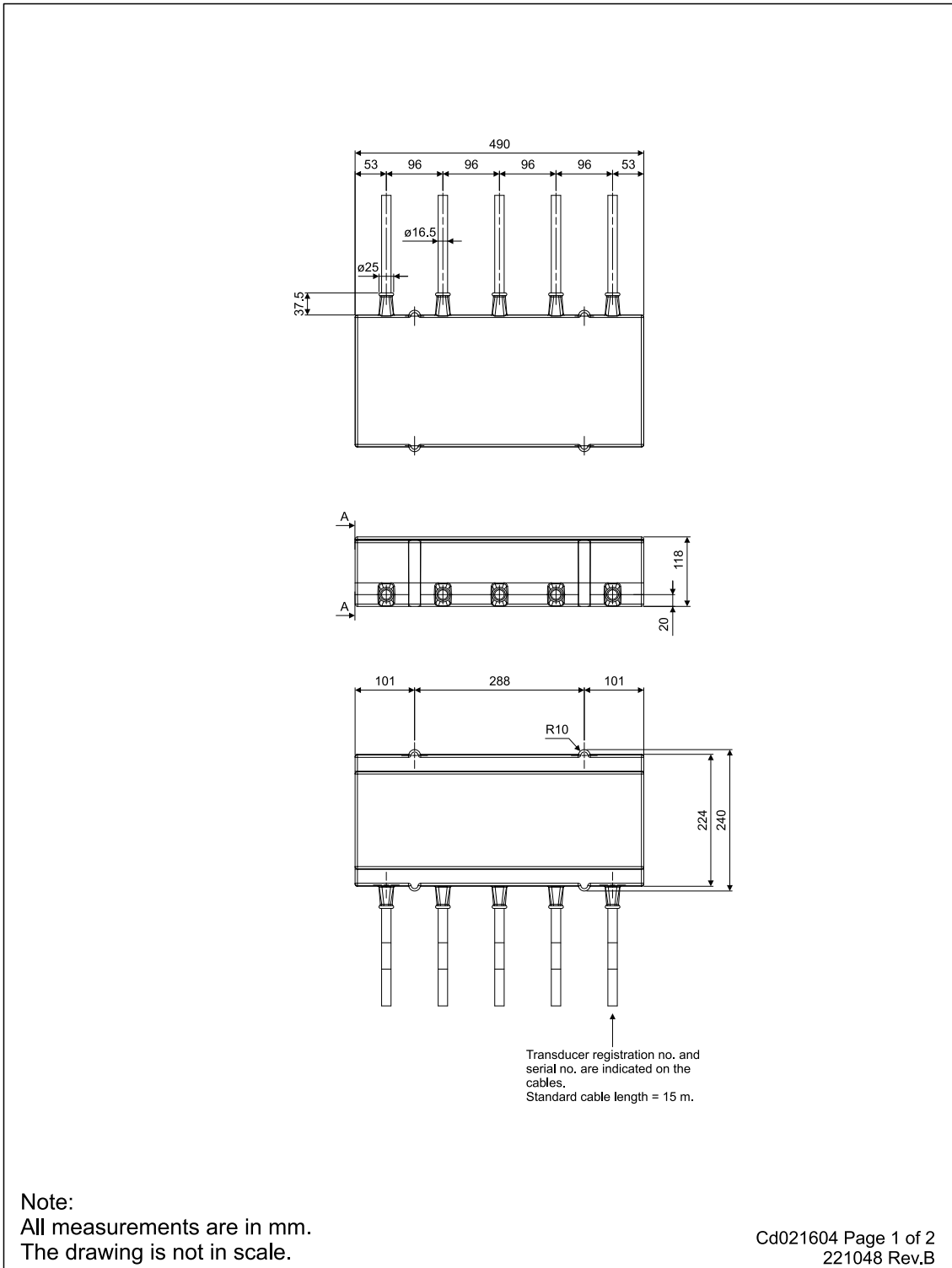

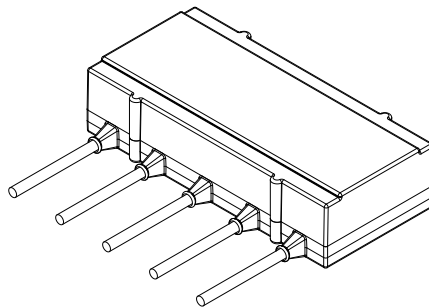
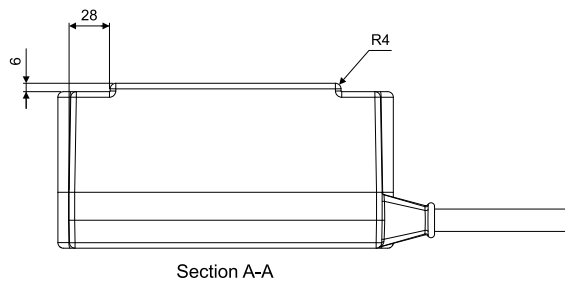

Note:
All measurements are in mm.
The drawing is not in scale.

Cd021604 Page 2 of 2
221048 Rev.B

10.1.7 Transducer RX1 Outline dimensions

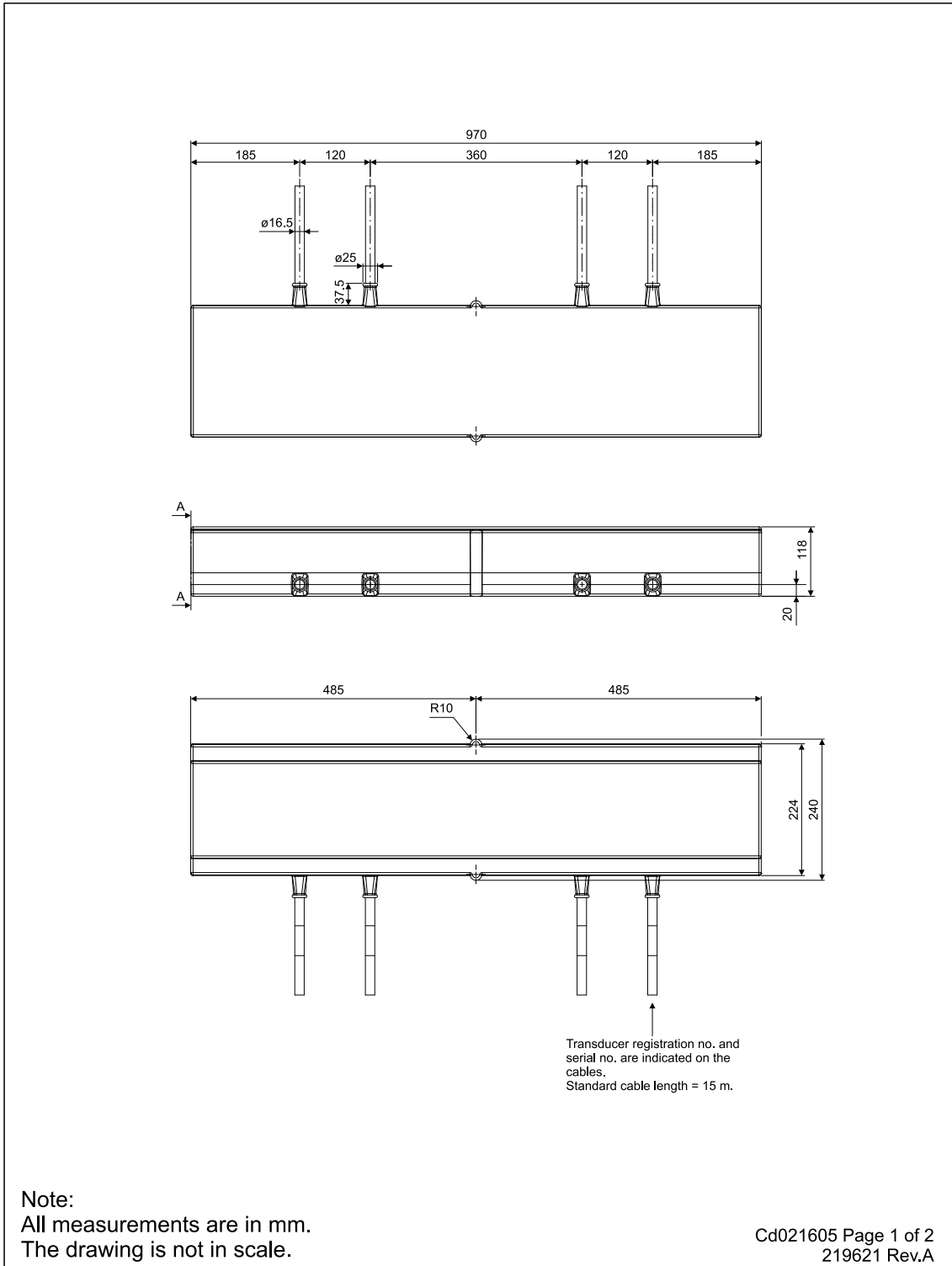

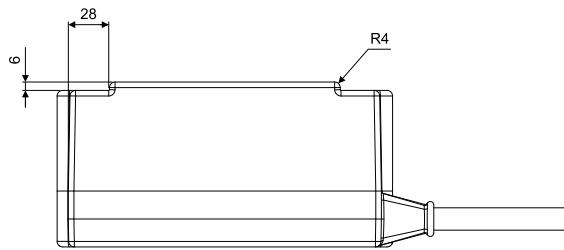

Section A-A

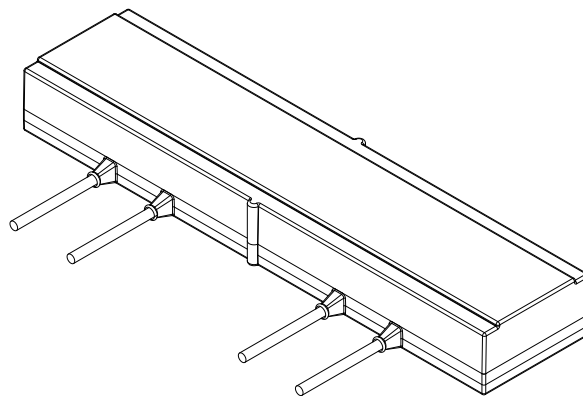

Note:
All measurements are in mm.
The drawing is not in scale.

Cd021605 Page 2 of 2
219621 Rev.A

10.1.8 Transducer RX2 Outline dimensions

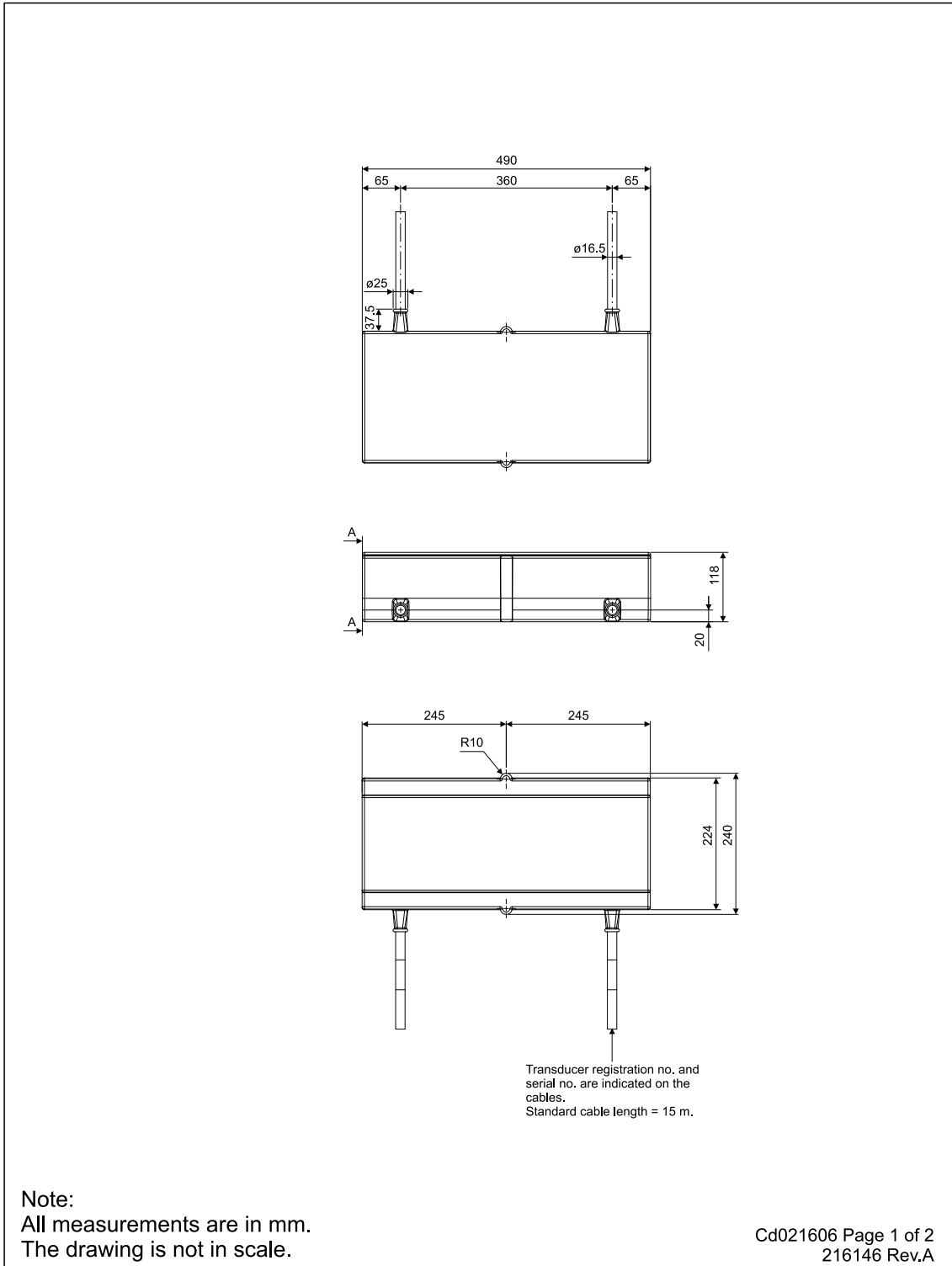

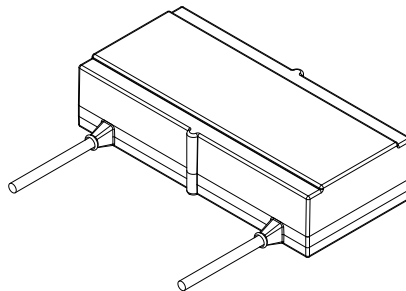
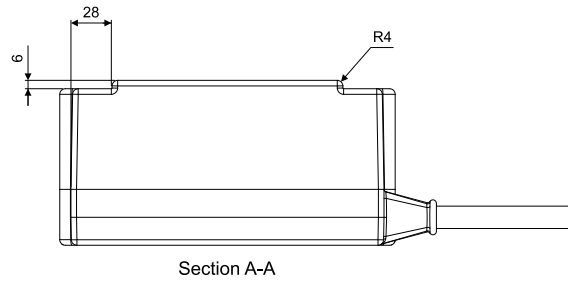

Note:
All measurements are in mm.
The drawing is not in scale.

CD021606 Page 2 of 2
216146 Rev.A

10.1.9 HWS Operator Station Outline dimensions



19" LCD:
Width = 483 mm
Height = 444 mm
Depth = 68 mm
Weight = 12 kg



HWS 19" Rack:
Width = 427 mm
Height = 180 mm/4U
Depth = 480 mm
Weight = 20 kg

Note:
All measurements are in mm.
The drawing is not in scale

Cd021046 Page 1 of 1
307181 Rev. A

10.1.10 Transceiver Unit Outline dimensions

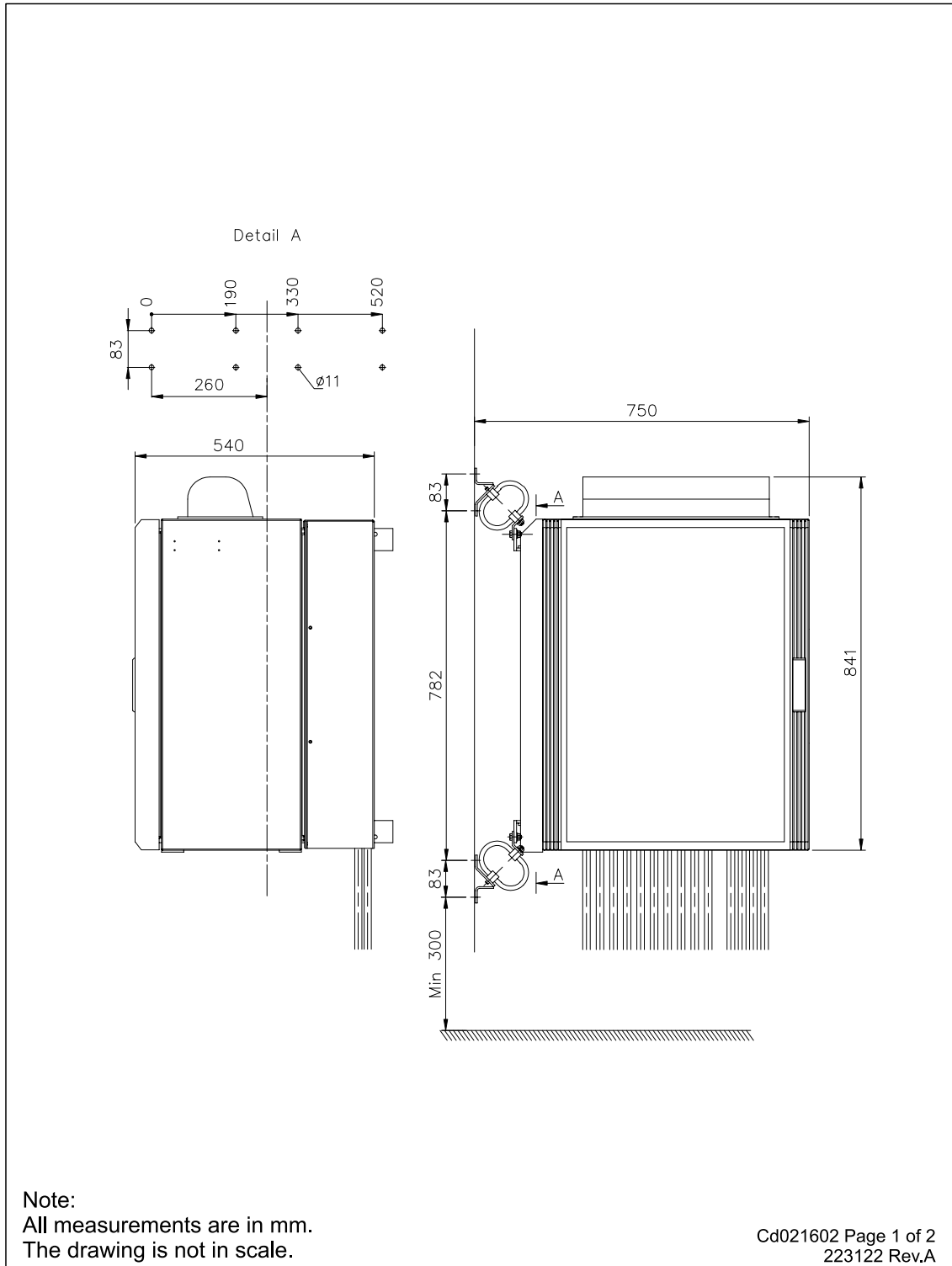

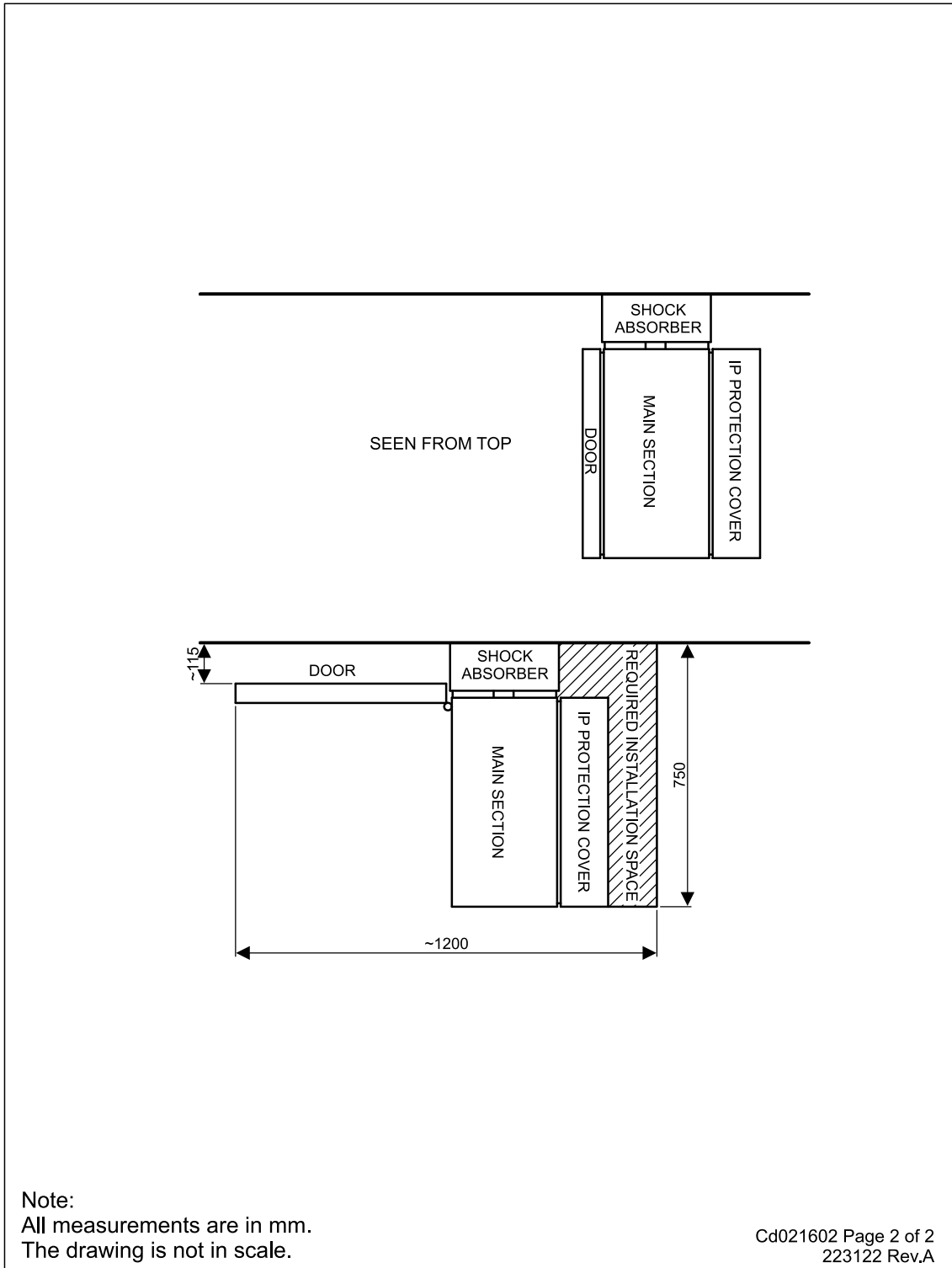

10.1.11 Transceiver Unit 2 x 2 degree system – Outline dimensions

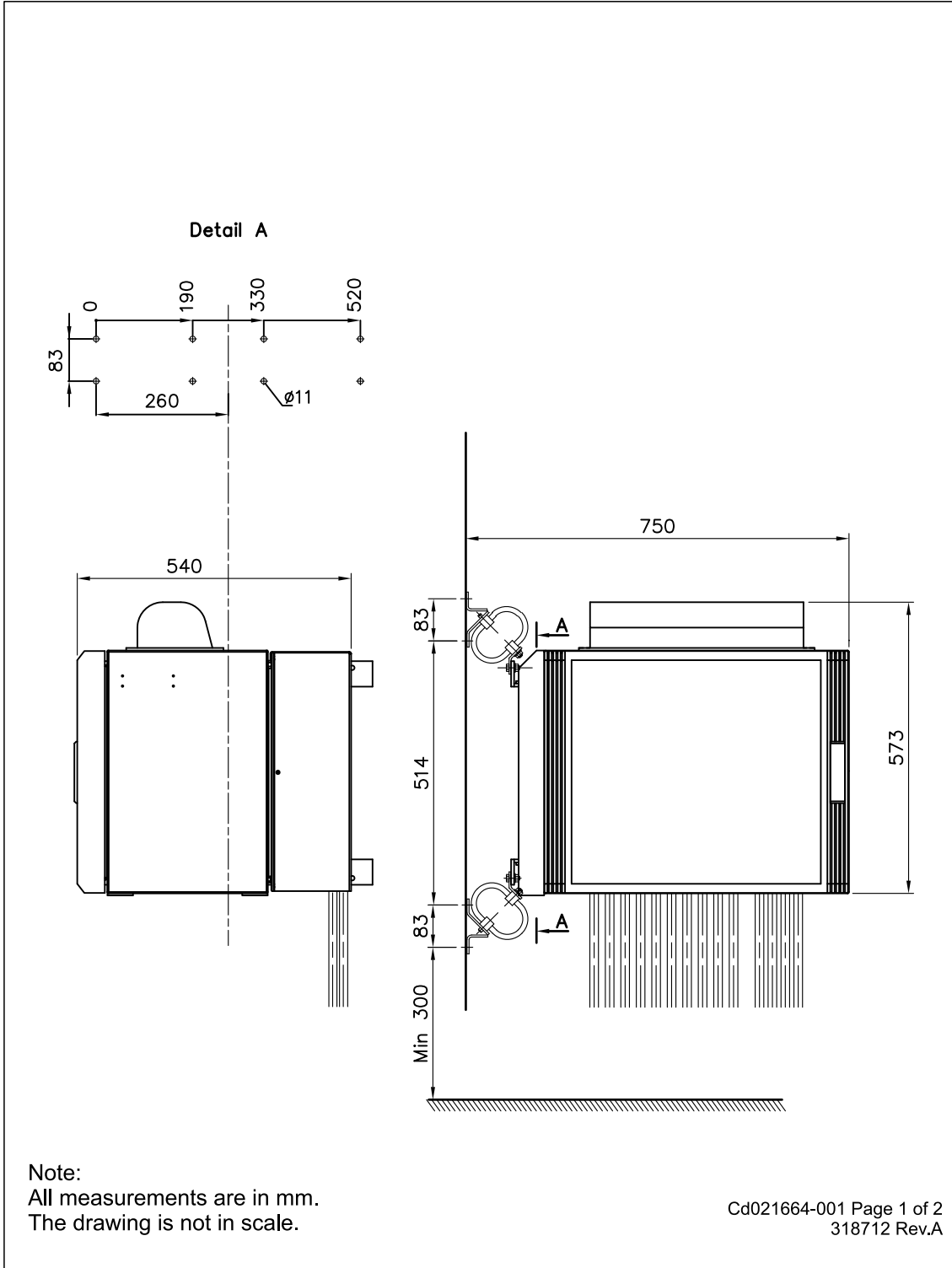

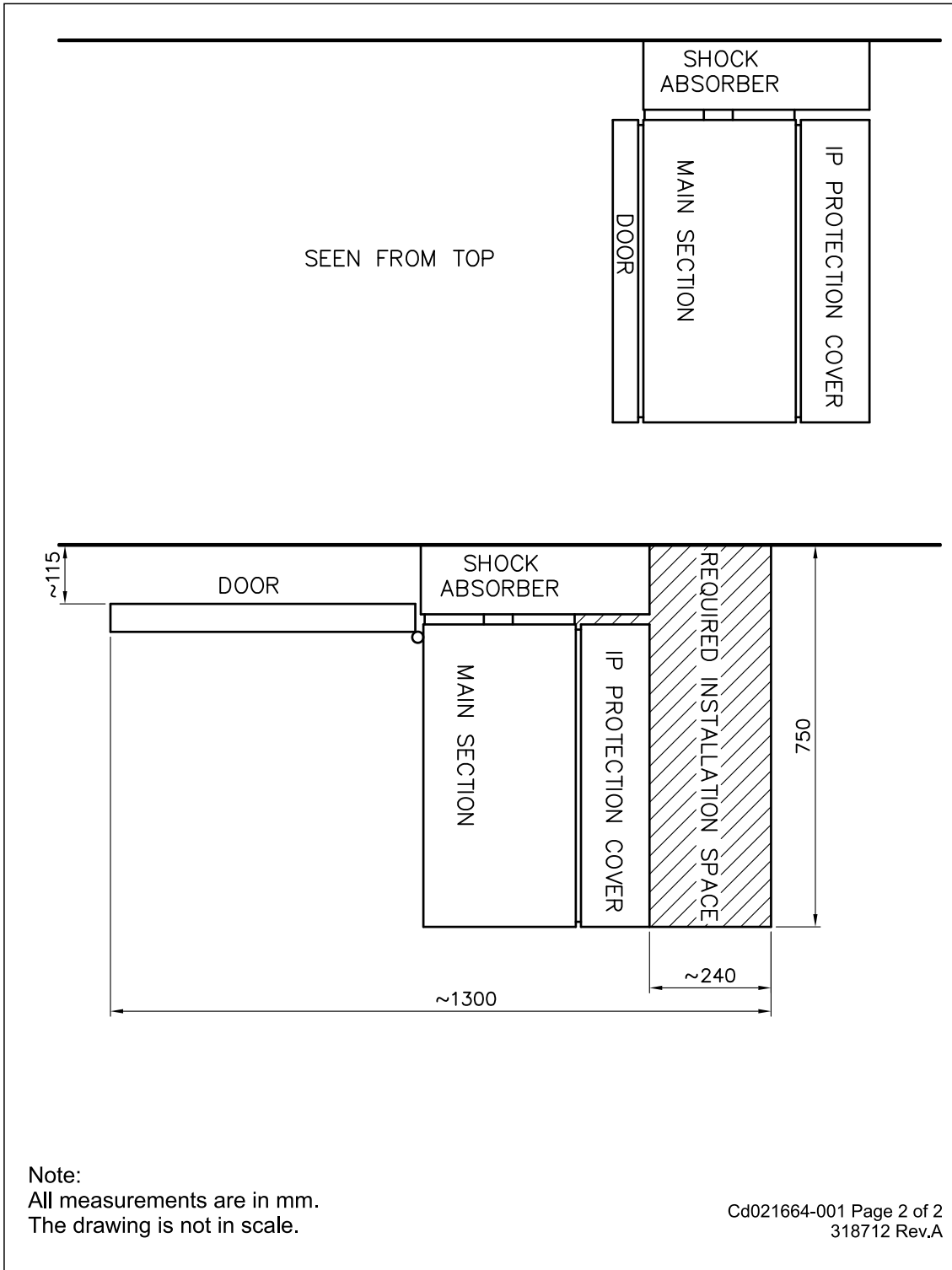

10.1.12 Transceiver Unit mounting bracket

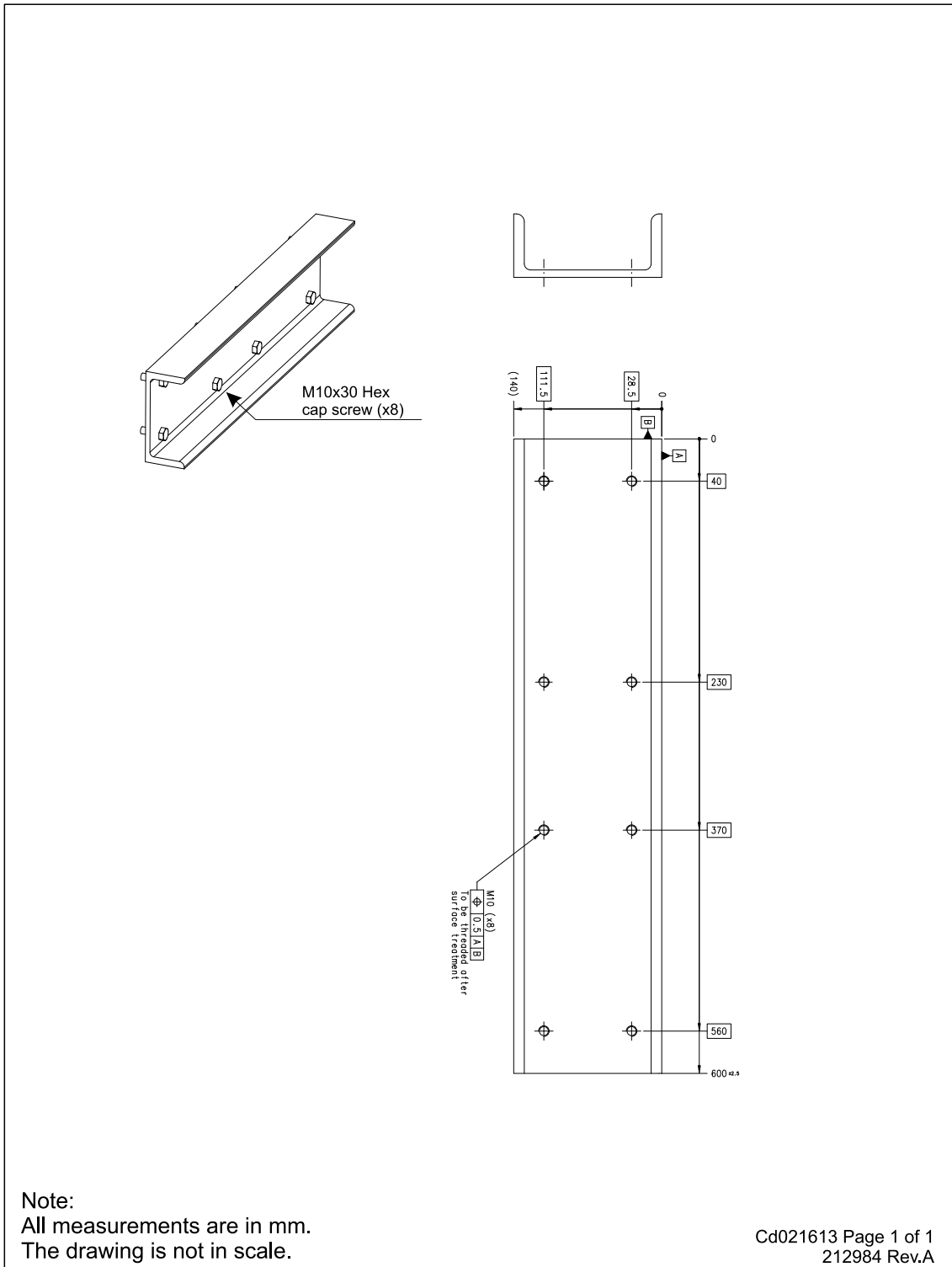

10.1.13 Junction Box – outline dimensions

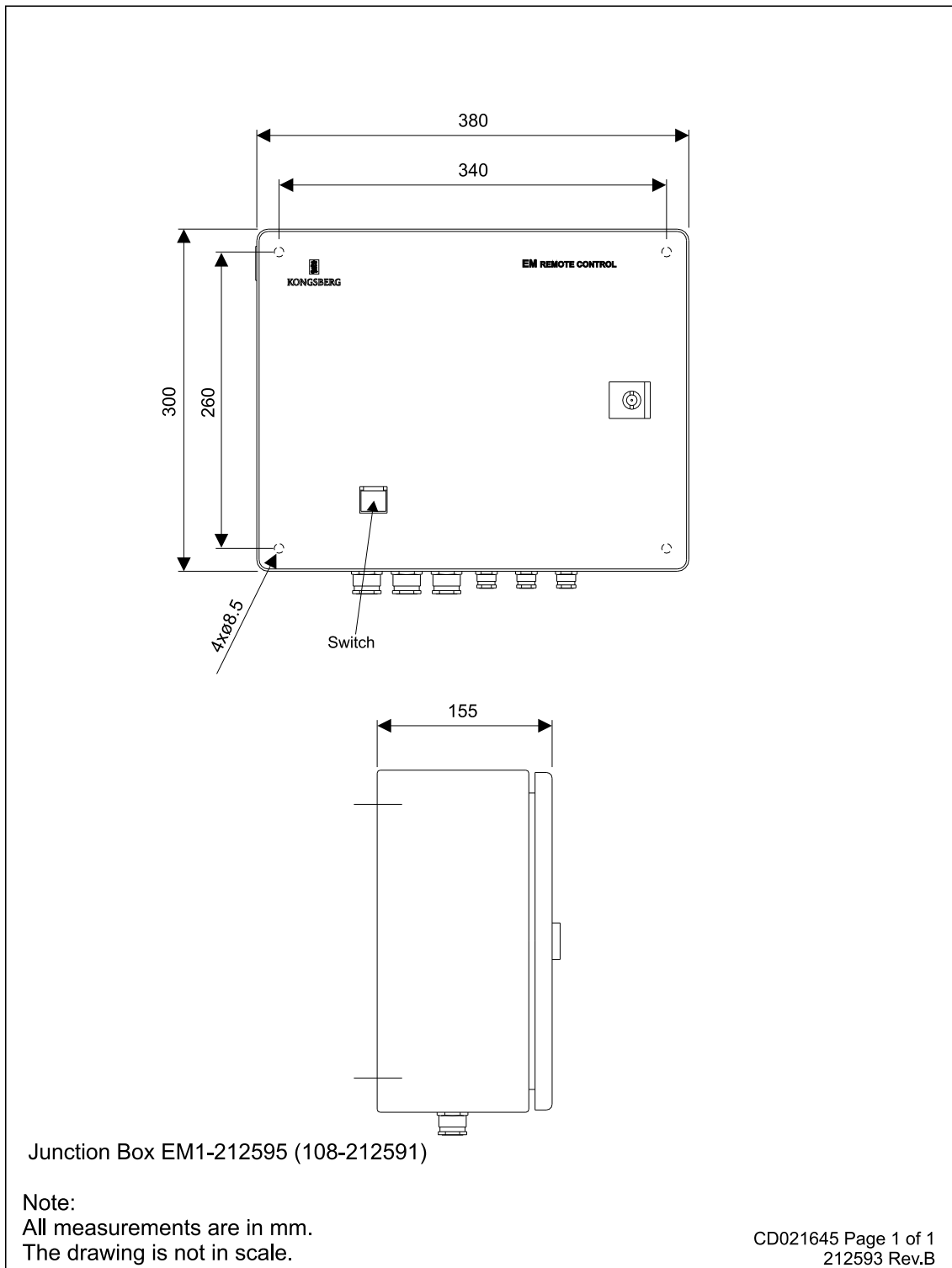

10.1.14 Transceiver Unit cable clamp

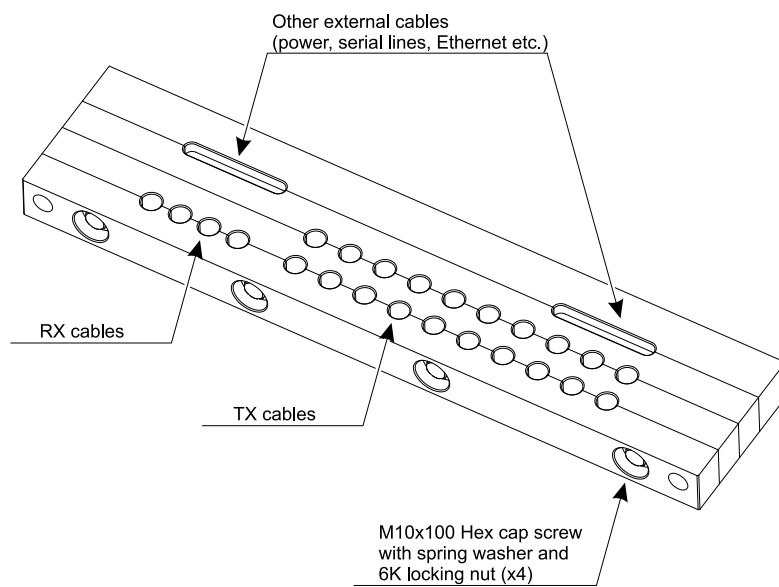

Note:
All measurements are in mm.
The drawing is not in scale.

Cd021614 Page 1 of 1
223163 Rev.A

10.2 Cable Drawings

10.2.1 Generic RS-232 Serial line

This cable comprises a multi purpose serial line. It provides interface with any peripheral unit. One end of the cable connects to the local unit (**DTE**) with a 9-pin D-connector, while the other connects to the peripheral (**DCE**) as described in the peripheral unit's documentation.

In many cases, only the **RXD**, **TXT** and **GND** pins are used. Twisted pairs are sufficient in the cable.

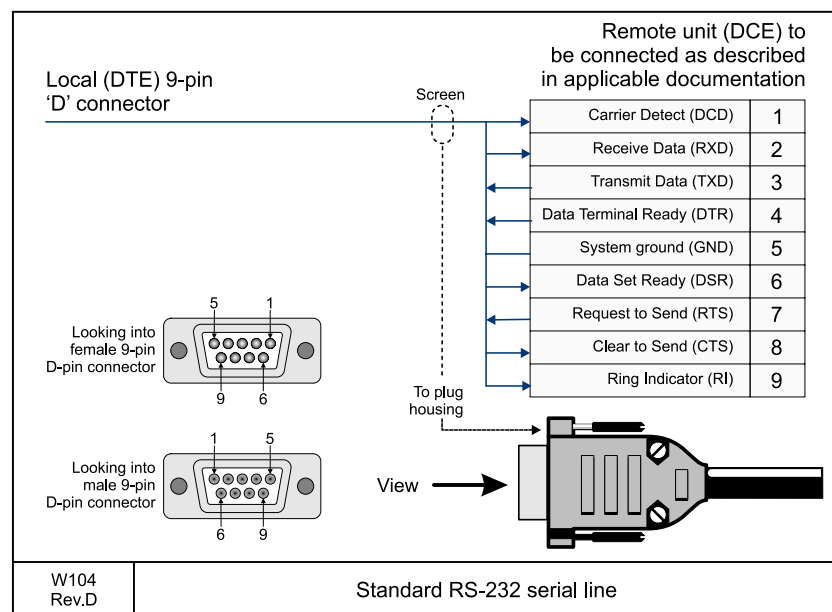

Cable specifications

- Conductors: 5 x 2 x 0.5 mm²
- Screen: Screened twisted pairs and overall braided
- Voltage: 60 V
- Maximum diameter: Limited by the plugs

10.2.2 Generic coax cable

This cable is used for connections to peripheral units or networks.

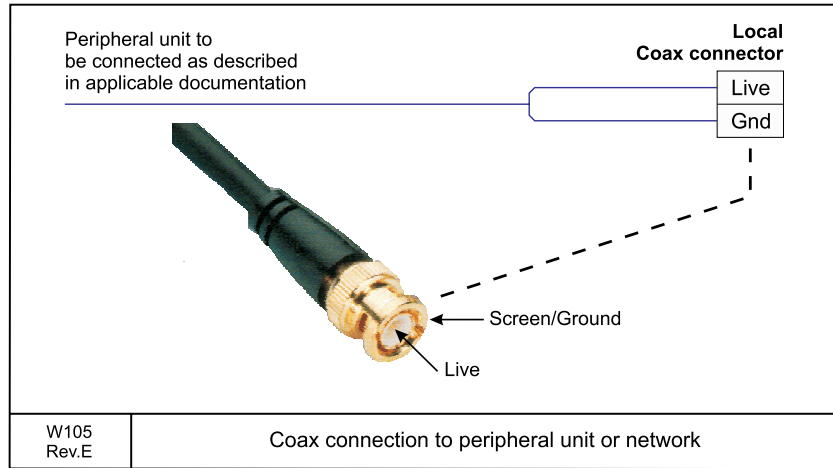

10.2.3 Sound speed probe interface

This cable provides the interconnection between the Processor Unit work station and the sound speed probe. This connection is normally made through a small junction box and with a power supply as indicated in the drawing.

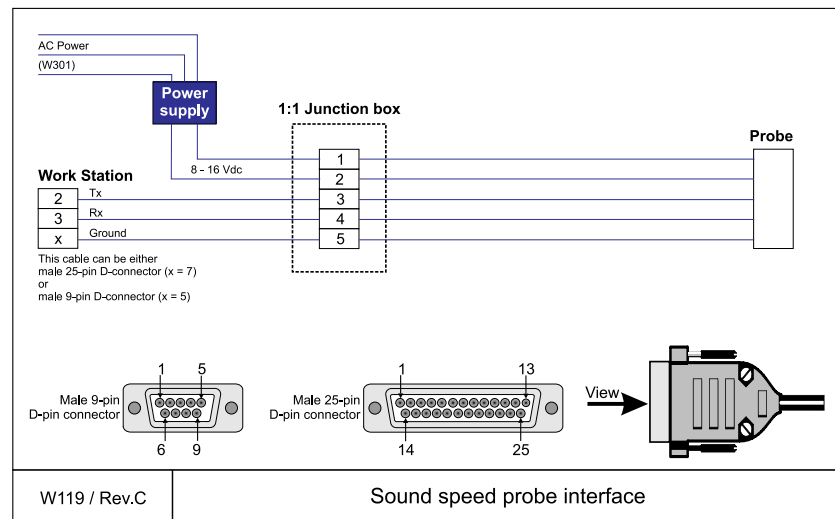

The cable between the junction box and the probe is supplied by the probe manufacturer.

- Conductors: 2 x 2 x 0.5 mm²
- Screen: Screened twisted pairs and overall braided
- Voltage: 60 V
- Maximum diameter: Limited by the plugs

10.2.4 RS-232 or RS-422/485 serial line

This cable comprises a multi-purpose serial line. It provides interface with any peripheral unit. One end of the cable connects to the local unit (DTE) with a 9-pin “D” connector, while the other connects to the peripheral (DCE) as described in the peripheral unit’s documentation.

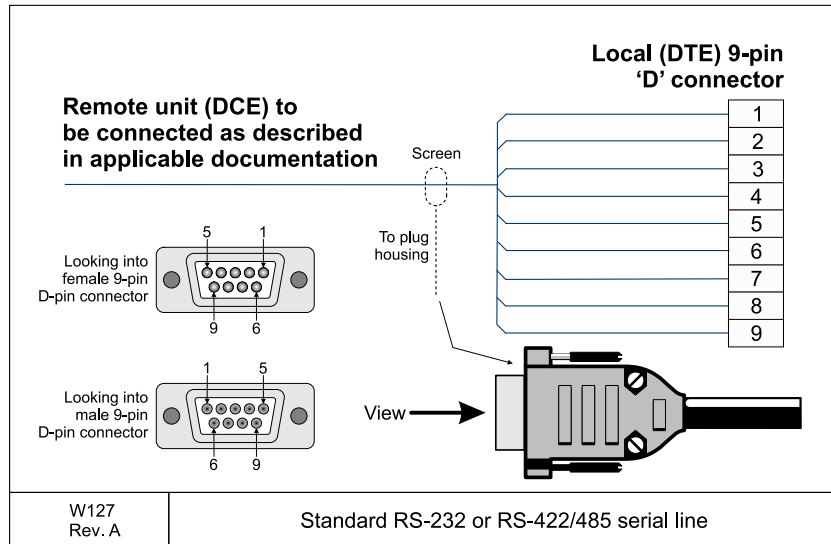

- Conductors: 6 x 2 x 0.5 mm²
- Screen: Screened twisted pairs and overall braided
- Voltage: 60 V
- Maximum diameter: Limited by the plugs

10.2.5 Trigger in/out (not used)

This cable is used to synchronize the echo sounder's transmissions with other acoustic instruments. It is terminated in a standard 9-pin D-sub connector at the Transceiver Unit end.

The cable is normally not used.

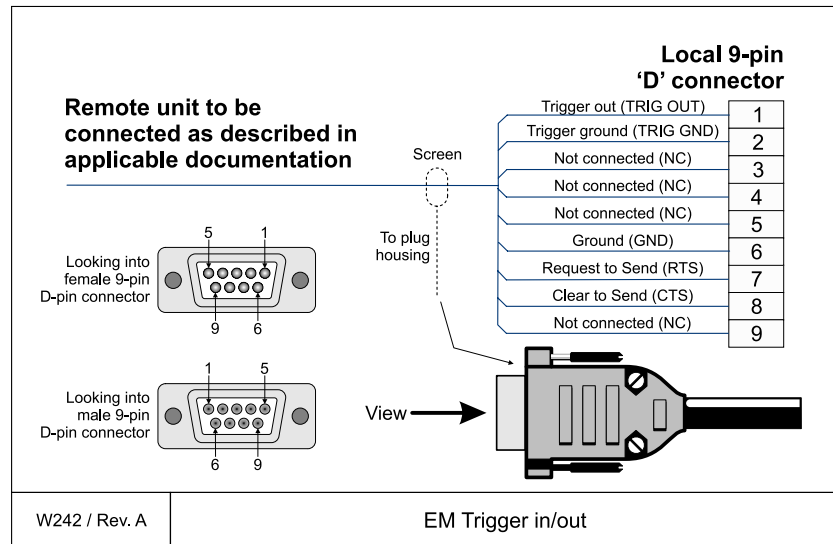

- Conductors: 5 x 2 x 0.5 mm²
- Screen: Screened twisted pairs and overall braided
- Voltage: 60 V
- Maximum diameter: Limited by the plugs

10.2.6 Internal control signals

This cable is used to transmit synchronization signals and TX enable signals. It is terminated in a standard 15-pin D-sub connector.

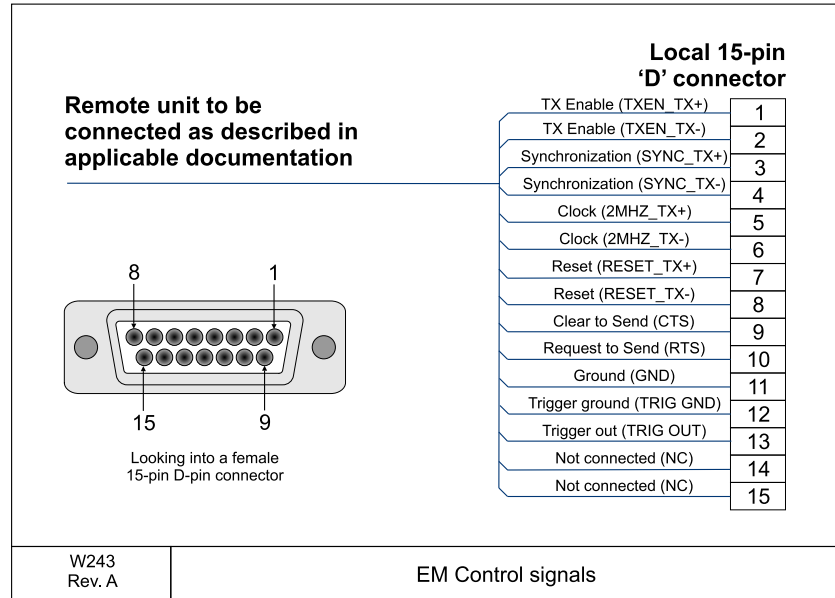

- Conductors: 9 x 2 x 0.5 mm²
- Screen: Screened twisted pairs and overall braided
- Voltage: 60 V
- Maximum diameter: Limited by the plugs

10.2.7 Remote control and external trig

This cable connects the EM 710 Transceiver Unit to a remote On/Off switch, normally located in a Remote Control junction box.

The same connection allows trigger output and remote control (synchronization) with a serial line.

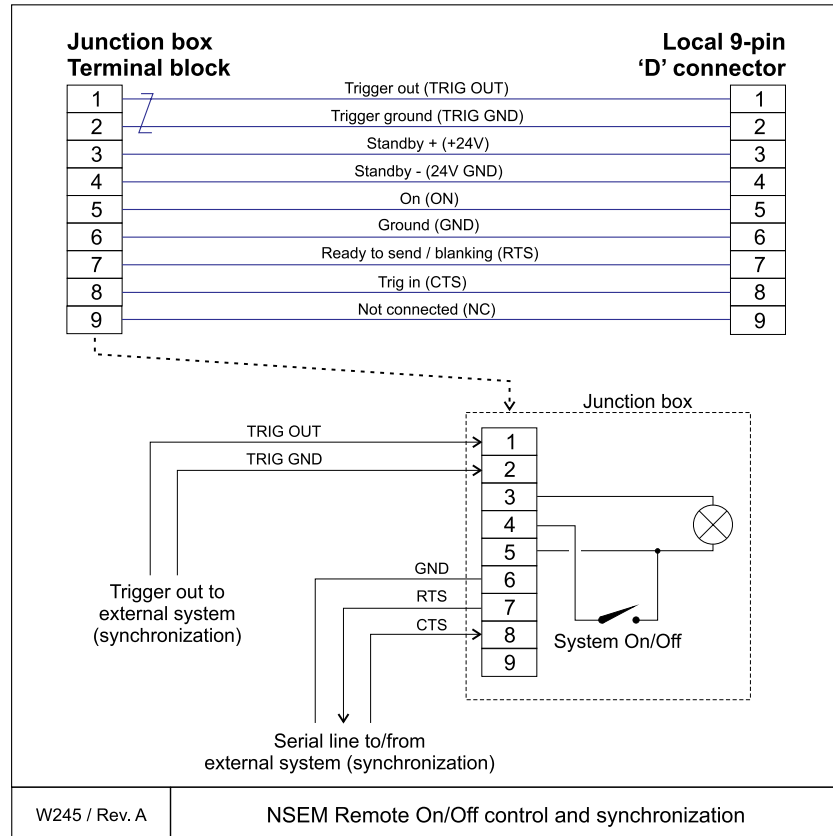

- Conductors: 5 x 2 x 0.5 mm²
- Screen: Overall braided
- Voltage: 60 V
- Maximum diameter: Limited by the plugs

10.2.8 Standard AC power cable

This cable is a standard three-wire power cable. The instrument end is terminated in a standard IEC female socket, while the other end is terminated in a plug suitable for the local standard.

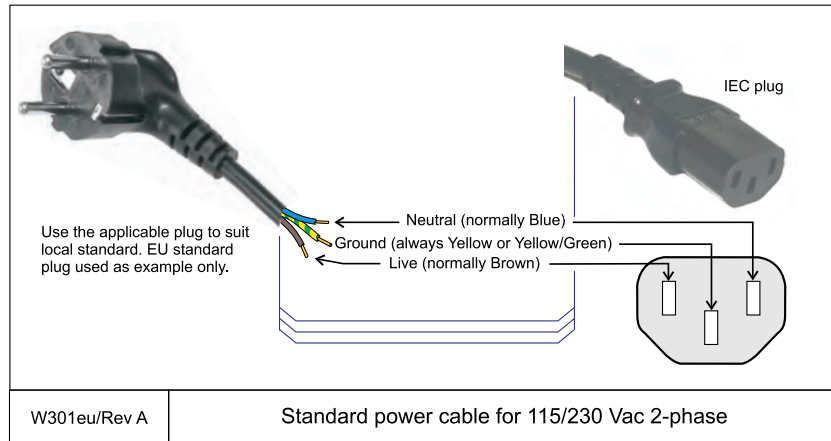

Note

*Different cable colours may be used for the **live** and **neutral** wires. Ground is however always on green/yellow.*

- Conductors: 3 x 1.5 mm²
- Screen: None
- Voltage: 750 V
- Maximum diameter: Defined by the manufacturer

10.2.9 Ethernet cable with RJ45

This cable is used to provide standard Ethernet connections. Note that various categories exist. **Cat.5 E** and **Cat.6** cables are used in local area networks with data rate exceeding 100 Mbit/s.

Ethernet cables are available commercially in different lengths, colours and categories.

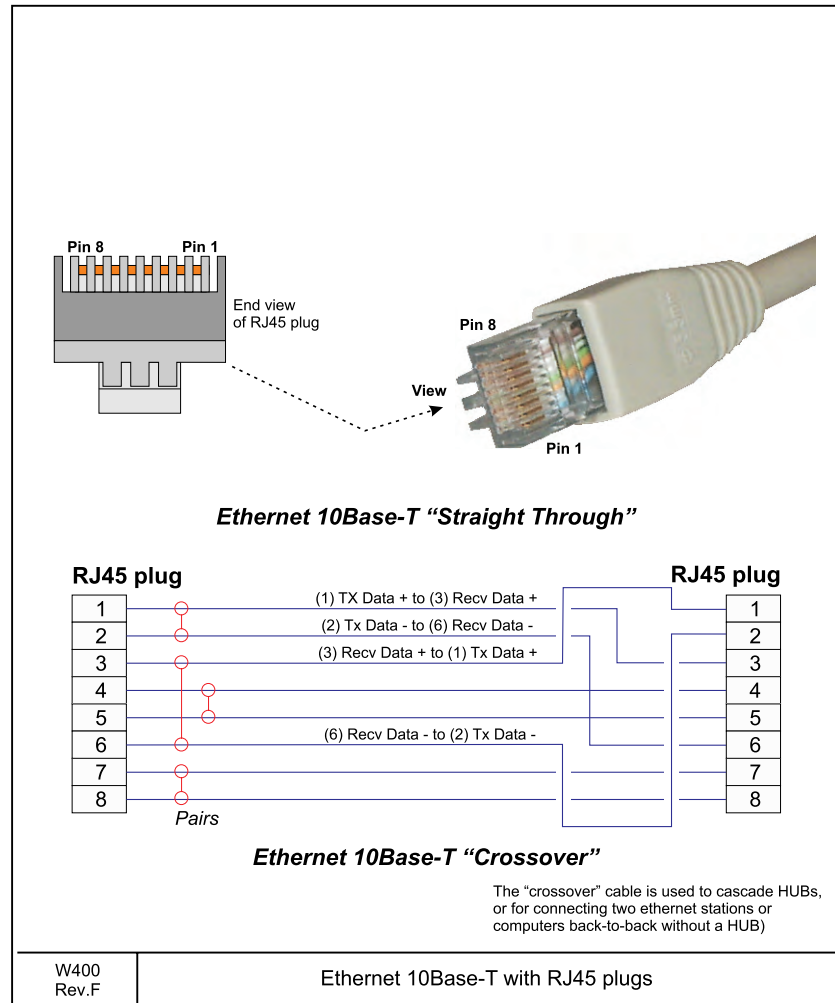

Screened category 6 (or 5 E) twisted pair cable to fit the specific RJ45 connectors used. AWG 23 and 24 size conductors are recommended.

10.2.10 VGA/SVGA Display cable

This is a standard commercial SVGA/VGA display cable used to connect the video signals. The cable is normally physically attached to the display monitor, and it is provided with the plug readily attached. If it is supplied as a separate cable, it is fitted with plugs on either end.

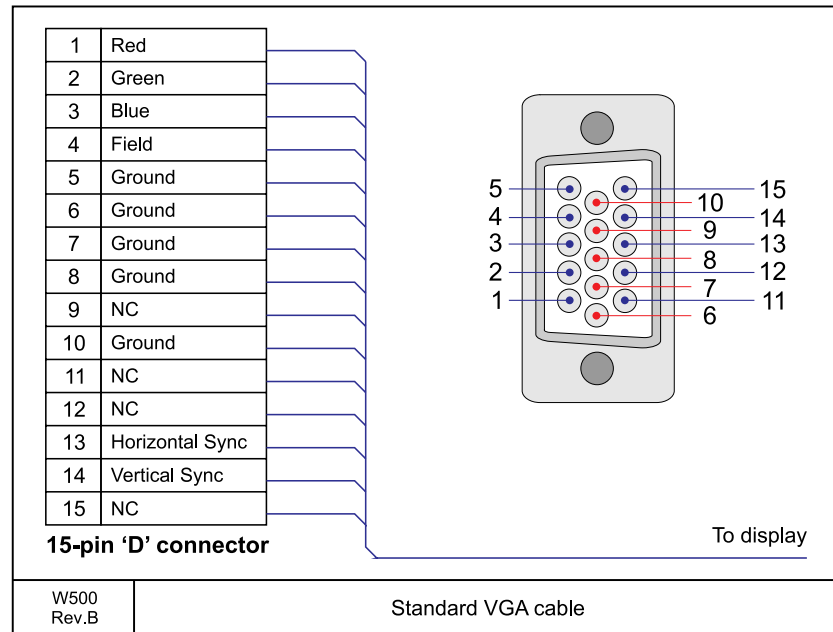

- Conductors: Defined by the manufacturer
- Screen: Defined by the manufacturer
- Voltage: Defined by the manufacturer
- Maximum diameter: Defined by the manufacturer
- Termination: Normally 15-pin D-connector(s)

10.2.11 USB cable

Just about any computer that you buy today comes with one or more Universal Serial Bus (USB) connectors on the back. These connectors let you attach everything from mouse to printers to your computer quickly and easily. Since the operating system supports USB, installation of device drivers is also easy.

In most cases, the USB cable is commercial, and they are normally supplied with the external devices, However, USB cables are also available commercially in different fixed lengths.

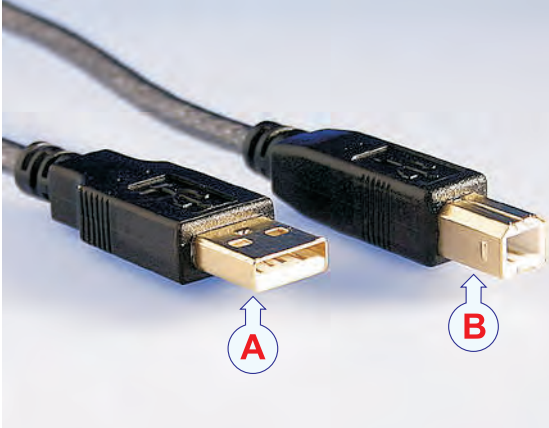
<p>Universal Serial Bus (USB) cable terminated with an A-plug in one end and a B-plug in the other.</p> <p>Internal cables:</p> <p>Pair 1: 28 AWG twisted pair (data, green, white)</p> <p>Pair 2: 20 AWG twisted pair (Power, red, black)</p> <p>Shield: Foil and braid</p>	
<p>W501 Rev.B</p>	<p>Commercial USB cable</p>

10.2.12 Keyboard cable

This is a standard keyboard cable. The cable is normally physically connected to the keyboard. It is terminated in a plug suited to fit the computer. Several keyboard types are available for different languages and hardware platforms. Both the keyboard and the attached cable are commercial items.

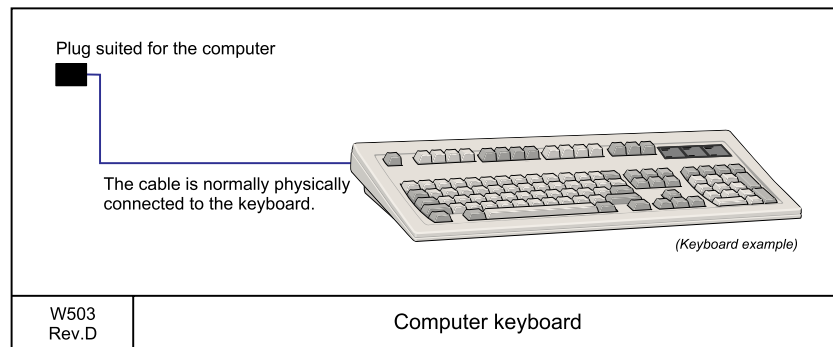

- Conductors: Defined by the manufacturer
- Screen: Defined by the manufacturer
- Voltage: Defined by the manufacturer
- Maximum diameter: Defined by the manufacturer
- Termination: USB, DIN or similar

10.2.13 Mouse cable

This is a standard mouse (or other pointing device) cable. It is physically connected to the mouse, and terminated in a plug suited to fit the computer. Several mouse and pointing device types are available with two or three buttons, and with or without a scroll wheel. Both the mouse and the attached cable are commercial items.

On Unix work stations, the mouse is normally connected to the keyboard.

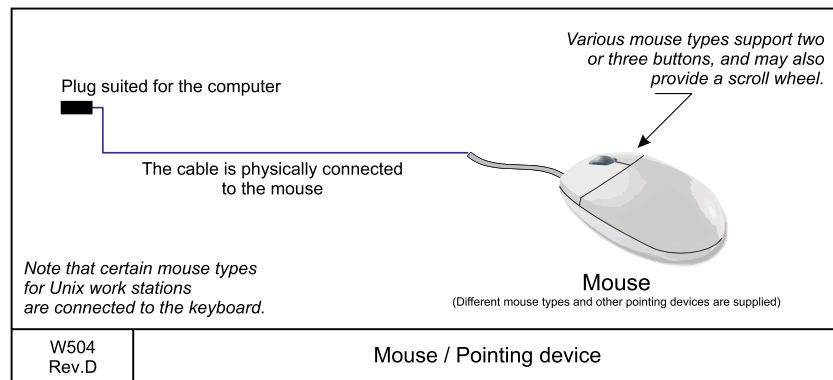

- Conductors: Defined by the manufacturer
- Screen: Defined by the manufacturer
- Voltage: Defined by the manufacturer
- Maximum diameter: Defined by the manufacturer
- Termination: USB, PS2 or similar

10.2.14 Parallel printer

This is a standard “Centronics” parallel printer cable. It is provided ready-made with printers, and also obtainable from commercial retailers.

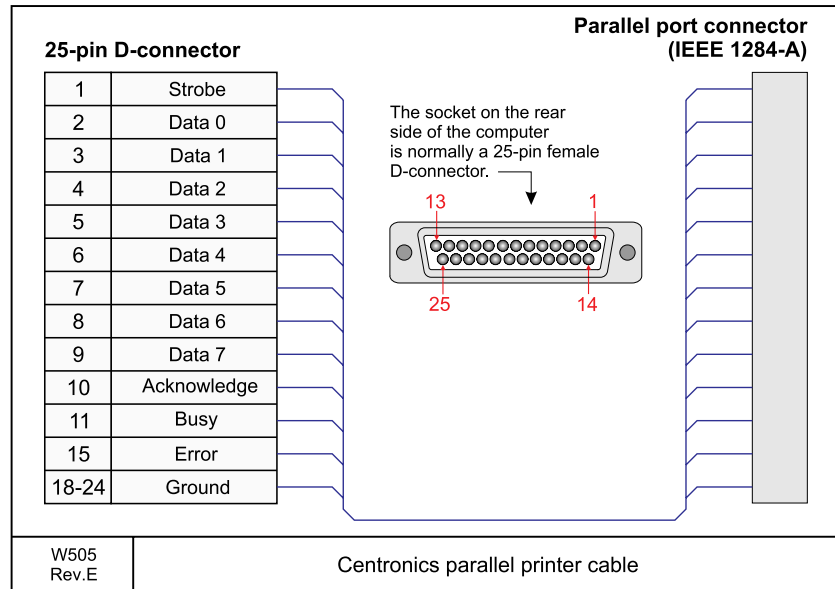

Cable specifications

- Conductors: Defined by the standard
- Screen: Defined by the cable manufacturer, normally overall braided
- Voltage: 60V
- Maximum diameter: Defined by the cable manufacturer
- Termination: 25-pin “D-sub” connector in one end, parallel port connector in the other end (IEEE 1284-A)

10.2.15 RX/TX transducer cables

These are the cables from the EM 710 Transceiver Unit to the RX/TX transducer arrays. Each cable is terminated at the cabinet's rear through a 78-pin D-sub connector. At the transducer end, the cables are moulded to their respective arrays. The cables are supplied by manufacturer.

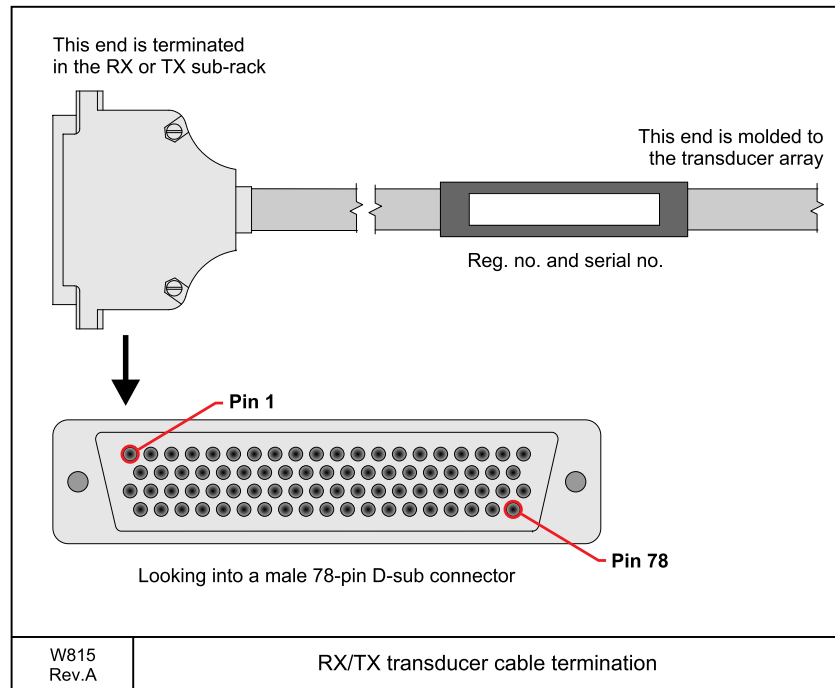

The following table displays the pin assignment in the transducer cable from the RX RIO board in the Transceiver Unit to the RX transducer

Table 9 RX transducer cable pin assignment

Module no.	Element no.	Pin no.		Wire colour code	
1	1	1	21	White	Brown
1	2	40	60	Green	Yellow
1	3	2	22	Grey	Pink
1	4	41	61	Blue	Red
1	5	3	23	Black	Violet
1	6	42	62	Grey/pink	Red/blue
1	7	4	24	White/green	Brown/green
1	8	43	63	White/yellow	Yellow/brown
1	9	5	25	White/grey	Grey/brown
1	10	44	64	White/pink	Pink/brown
1	11	6	26	White/blue	Brown/blue
1	12	45	65	White/red	Brown/red

Table 9 RX transducer cable pin assignment (cont'd.)

Module no.	Element no.	Pin no.		Wire colour code	
1	13	7	27	White/black	Brown/black
1	14	46	66	Grey/green	Yellow/grey
1	15	8	28	Pink/green	Yellow/pink
1	16	47	67	Green/blue	Yellow/blue
2	1	9	29	Grey/blue	Pink/blue
2	2	48	68	Grey/red	Pink/red
2	3	10	30	Grey/black	Pink/black
2	4	49	69	Blue/black	Red/black
2	5	11	31	White	Brown
2	6	50	70	Green	Yellow
2	7	12	32	Grey	Pink
2	8	51	71	Blue	Red
2	9	13	33	Black	Violet
2	10	52	72	Grey/pink	Red/blue
2	11	14	34	White/green	Brown/green
2	12	53	73	White/yellow	Yellow/brown
2	13	15	35	White/grey	Grey/brown
2	14	54	74	White/pink	Pink/brown
2	15	16	36	White/blue	Brown/blue
2	16	55	75	White/red	Brown/red

The following table displays the pin assignment in the transducer cable from the TX RIO board in the Transceiver Unit to the TX transducer.

Table 10 TX transducer cable pin assignment

Element no.	Pin no.		Wire colour code	
1	1	21	White	Brown
2	2	22	Green	Yellow
3	3	23	Grey	Pink
4	4	24	Blue	Red
5	5	25	Black	Violet
6	6	26	Grey/pink	Red/blue
7	7	27	White/green	Brown/green
8	8	28	White/Yellow	Yellow/brown
9	9	29	White/grey	Grey/brown
10	10	30	White/pink	Pink/brown
11	11	31	White/blue	Brown/blue
12	12	32	White/red	Brown/red

Table 10 TX transducer cable pin assignment (cont'd.)

Element no.	Pin no.		Wire colour code	
13	13	33	White/black	Brown/black
14	14	34	Grey/green	Yellow/grey
15	15	35	Pink/green	Yellow/pink
16	16	36	Green/blue	Yellow/blue
17	17	37	Green/red	Yellow/red
18	18	38	Green/black	Yellow/black
19	40	60	Grey/blue	Pink/blue
20	41	61	Grey/red	Pink/red
21	42	62	Grey/black	Pink/black
22	43	63	Blue/black	Red/black
23	44	64	White	Brown
24	45	65	Green	Yellow
25	46	66	Grey	Pink
26	47	67	Blue	Red
27	48	68	Black	Violet
28	49	69	Grey/pink	Red/blue
29	50	70	White/green	Brown/green
30	51	71	White/yellow	Yellow/brown
31	52	72	White/grey	Grey/brown
32	53	73	White/pink	Pink/brown
33	54	74	White/blue	Brown/blue
34	55	75	White/red	Brown/red
35	56	76	White/black	Brown/black
36	57	77	Grey/green	Yellow/grey

©January 2009 Kongsberg Maritime

Kongsberg Maritime AS

Strandpromenaden 50
P.O.Box 111
N-3191 Horten,
Norway

Telephone: +47 33 02 38 00
Telefax: +47 33 04 47 53
www.kongsberg.com
subsea@kongsberg.com



KONGSBERG

**EM 710 Multibeam echo sounder
Installation manual**

**EM 710 Multibeam echo sounder
Maintenance manual**

Maintenance Manual

EM 710 Multibeam echo sounder

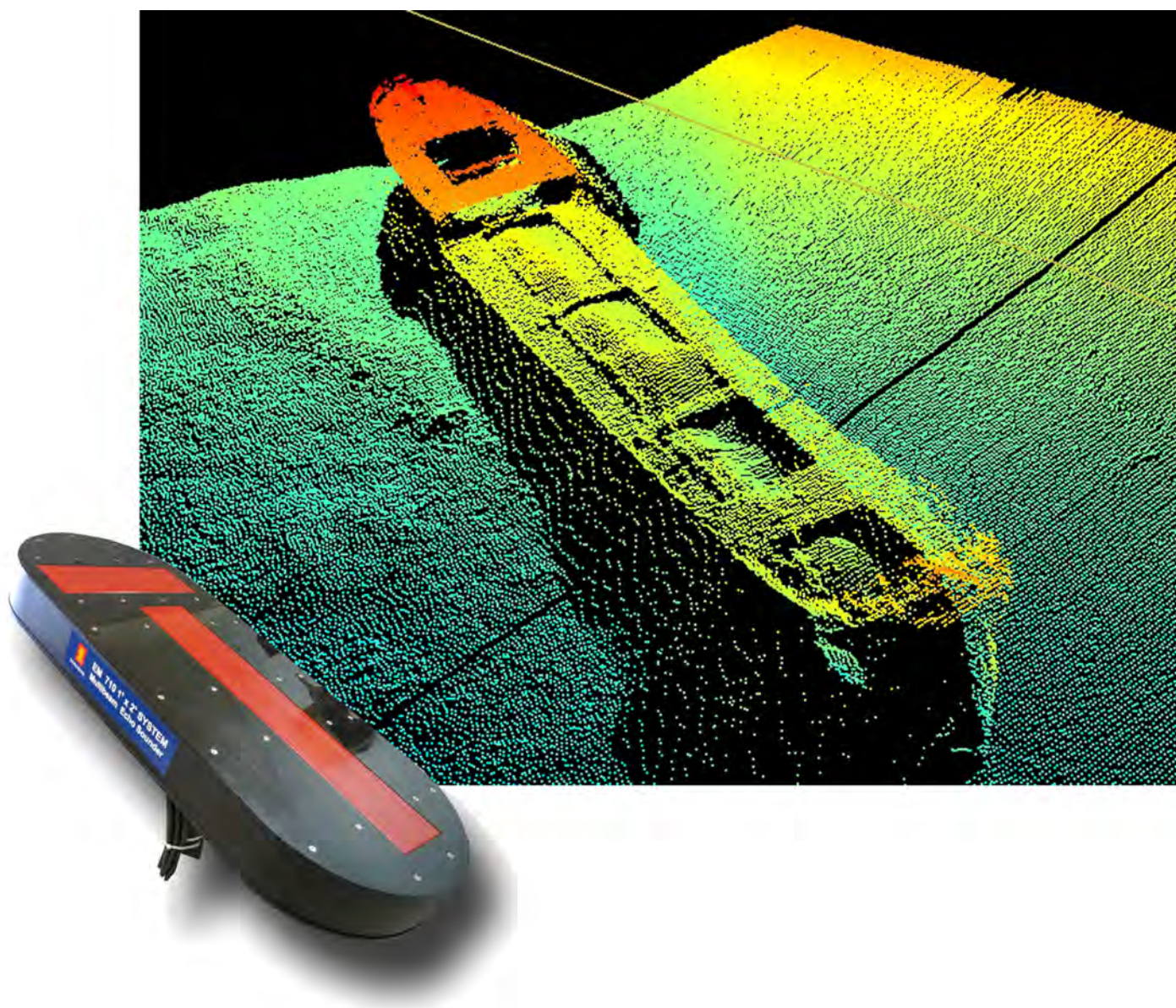

Kongsberg EM 710 Multibeam echo sounder

Maintenance manual

Kongsberg Maritime

Document history

Document number: 851-164852		
Rev. A	January 2006	First version.
Rev. B	June 2009	New drawings and changes in text

Note

The information contained in this document remains the sole property of Kongsberg Maritime AS. No part of this document may be copied or reproduced in any form or by any means, and the information contained within it is not to be communicated to a third party, without the prior written consent of Kongsberg Maritime AS.

Kongsberg Maritime AS endeavours to ensure that all information in this document is correct and fairly stated, but does not accept liability for any errors or omissions.

Warning

The equipment to which this manual applies must only be used for the purpose for which it was designed. Improper use or maintenance may cause damage to the equipment and/or injury to personnel. The user must be familiar with the contents of the appropriate manuals before attempting to operate or work on the equipment.

Kongsberg Maritime disclaims any responsibility for damage or injury caused by improper installation, use or maintenance of the equipment.

Comments

To assist us in making improvements to the product and to this manual, we welcome comments and constructive criticism.

e-mail: km.documentation@kongsberg.com

Kongsberg Maritime AS

Strandpromenaden 50
P.O.Box 111
N-3191 Horten,
Norway

Telephone: +47 33 02 38 00
Telefax: +47 33 04 47 53
www.kongsberg.com
subsea@kongsberg.com



KONGSBERG

Table of contents

1	ABOUT THIS MANUAL	7
1.1	General	7
1.2	Maintenance philosophy.....	7
1.3	System overview	8
1.4	System characteristics	11
1.5	Optional	12
1.6	General safety rules	13
2	TECHNICAL SPECIFICATIONS	14
2.1	Interfaces	14
2.2	Physical specifications.....	15
2.3	Power requirements.....	16
2.4	Environmental and EMC specifications.....	17
2.5	System performance data	17
3	CABLE LAYOUT	19
3.1	System cabling	20
3.2	Operator Station cables	21
3.3	Transceiver Unit cables	22
3.3.1	Transceiver Unit – front view	23
3.3.2	Transceiver Unit – rear view.....	24
3.3.3	TRU compact – 2 x 2 degree system	25
3.3.4	Transceiver Unit – Cable configuration	27
3.4	Transducer cables	29
3.4.1	Transmit array cable markings.....	29
3.4.2	Receive array cable markings	32
3.5	Cable specifications.....	32
4	OPERATOR STATION	33
4.1	HWS overview	33
4.2	Technical description.....	34
4.3	HWS circuit boards and modules.....	34
5	TRANSCEIVER UNIT	35
5.1	Theory of operation	36
5.1.1	External synchronisation and remote on/off.....	38
5.1.2	Clock sync 1 PPS.....	39
5.2	Receiver rack (large TRU)	40
5.3	Transmitter rack.....	43
5.4	TRU compact 2 x 2 degree system.....	45
5.5	Circuit board descriptions	46

5.5.1	cPCI Power Supply	47
5.5.2	CPU Board with PMC Module	49
5.5.3	Kontron CP 6011 pentium CPU BOARD	51
5.5.4	BSP 67B Board	54
5.5.5	Ethernet Switch Board – Gigabit.....	56
5.5.6	Ethernet Switch Board – Megabit	58
5.5.7	Power Supply PSU 6V	60
5.5.8	RX32 receiver board	61
5.5.9	RX RIO – Rear Interface Board	67
5.5.10	RXP RIO – Rear Interface Board	68
5.5.11	BSP RIO – Rear Interface Board	69
5.5.12	Rear I/O Interface Board (Kontron)	70
5.5.13	Raw data logger interface (RDL)	72
5.5.14	TX36 transmitter board	73
5.5.15	Power Supply PSU 12V	79
5.5.16	TXP RIO – Rear Interface Board	81
5.5.17	TX RIO – Rear Interface Board	83
5.5.18	Power Supply PSU 72V	84
6	 TROUBLESHOOTING.....	85
6.1	Messages	85
6.2	BIST tests	85
7	 REPLACEMENT PROCEDURES	87
7.1	Procedures for Transceiver Unit.....	88
7.2	Power Supply	89
7.3	Fuse replacement.....	90
7.4	Fan drawers	90
7.5	New BSP RIO card and Jumper Link	91
8	 SPARE PARTS.....	93
9	 MAINTENANCE PROGRAM	95
9.1	Before every survey (alongside).....	95
9.2	Before every survey (offshore).....	95
9.3	Every time used	96
9.4	Every 6 months.....	96
9.5	Every dry-docking.....	96
10	 INSTALLATION DRAWINGS.....	98
10.1	Installation Drawings	99
10.1.1	0.5° mounting frame assembly TX module	99
10.1.2	1° mounting frame assembly RX module.....	101
10.1.3	2° mounting frame assembly TX/RX module.....	103
10.1.4	0.5 x 1° gondola.....	105
10.1.5	Transducer TX1 Outline dimensions	107

10.1.6	Transducer TX2 Outline dimensions	109
10.1.7	Transducer RX1 Outline dimensions	111
10.1.8	Transducer RX2 Outline dimensions	113
10.1.9	HWS Operator Station Outline dimensions	115
10.1.10	Transceiver Unit Outline dimensions	116
10.1.11	Transceiver Unit 2 x 2 degree system – Outline dimensions	118
10.1.12	Transceiver Unit mounting bracket	120
10.1.13	Junction Box – outline dimensions	121
10.1.14	Transceiver Unit cable clamp	122
10.2	Cable Drawings	123
10.2.1	Generic RS-232 Serial line	123
10.2.2	Generic coax cable	124
10.2.3	Sound speed probe interface	125
10.2.4	RS-232 or RS-422/485 serial line	126
10.2.5	Trigger in/out (not used)	127
10.2.6	Internal control signals	128
10.2.7	Remote control and external trig	129
10.2.8	Standard AC power cable	130
10.2.9	Ethernet cable with RJ45	131
10.2.10	VGA/SVGA Display cable	132
10.2.11	USB cable	133
10.2.12	Keyboard cable	134
10.2.13	Mouse cable	135
10.2.14	Parallel printer	136
10.2.15	RX/TX transducer cables	137

1 ABOUT THIS MANUAL

1.1 General

This is the maintenance manual for the EM 710 Multibeam echo sounder system.

The manual contains detailed descriptions of each of the units in the system. Each circuit board and mechanical assembly is described. The manual also describes the troubleshooting process based on the Built-In Self test (BIST) software, and it includes procedures for disassembly and reassembly of the replaceable items.

This manual does not describe the maintenance of the Operator Station and the peripheral devices (printers, plotters and sensors). For information about these items, refer to the applicable manufacturer's documentation. The manual will also list the unique boards in the different system delivered.

1.2 Maintenance philosophy

Kongsberg Maritime defines three levels for maintenance.

- 1 **Organizational:** You will only perform limited preventive and corrective maintenance on the system. There is no need for technical education or training, and no need for any instruments. Typical tasks are exterior cleaning, or changing fuses.
- 2 **Intermediate:** You will perform overall preventive and corrective maintenance on the system. It is recommended that you are an educated engineer with experience from computerized design and mechanical systems. It is further expected that you can use standard electronic instruments, such as an oscilloscope. You should be trained by Kongsberg Maritime to perform maintenance on the system. Typical tasks may include troubleshooting, testing and circuit board replacement.
- 3 **Depot:** You will perform detailed maintenance on the system and on the circuit boards and modules. You must be an educated engineer with experience of computerized design and mechanical systems. It is further expected that you can use standard electronic instruments, such as an oscilloscope. You should be trained by Kongsberg Maritime to perform maintenance on the system. Typical tasks are circuit board repair.

Note

This manual is prepared for the intermediate level.

1.3 System overview

Key facts

The EM 710 multibeam echo sounder is a high to very high resolution seabed mapping system capable of meeting all relevant survey standards. The system configuration can be tailored to the user requirements, allowing for choice of beamwidths as well as transmission modes. The minimum acquisition depth is from less than 3 m below its transducers, and the maximum acquisition depth is up to 2000 m.

Acrosstrack coverage (swath width) is up to 5.5 times water depth to a maximum of more than 2000 m. The sounding density is very high, allowing even the very demanding LINZ special order survey specification for object detection to be met in full.

There are three basic versions of the EM 710:

- EM 710 - Full performance version.
- EM 710S - CW pulse forms only.
- EM 710RD - Short CW pulse only.

The reduced performance versions EM 710S and EM 710RD are upgradable to full performance.

Innovative acoustic principles

The EM 710 operates at sonar frequencies in the 70 to 100 kHz range. The transmit fan is divided into three sectors to maximize range capability but also to suppress interference from multiples of strong bottom echoes. The sectors are transmitted sequentially within each ping, and uses distinct frequencies or waveforms.

Both CW pulses of different lengths and even longer, compressible waveforms (chirps) are utilized. The alongtrack beamwidth depends upon the chosen transducer configuration with 0.5, 1 and 2 degrees available as standard. Focusing is applied individually to each transmit sector to retain the angular resolution inside the near field. A ping rate of up to 25 per second is possible. The transmit fan is electronically stabilized for roll, pitch and yaw.

The EM 710 has a receive beamwidth of either 1 or 2 degrees depending on the chosen receive transducer. The number of beams is 256 or 128 respectively, with dynamic focusing employed in the near field.

A high density beam processing mode provides up to 400 or 200 soundings per swath by using a limited range window for the detections, which in practice is equivalent to synthetically sharpening the beamwidth.

The system will be able to generate two separate alongtrack swaths per ping. The system produces up to 800 (with 1 degree receive transducer) soundings per ping in this mode.

The beamspacing may be set to be either equiangular or equidistant. The receive beams are electronically roll stabilized. This can be used to increase the resolution beyond what is achievable in normal operation. In high density mode, the size of each acoustic footprint is reduced to fit the higher sounding density. The coverage may be limited by the operator either in angle or in swath width without reducing the number of beams. A combination of phase and amplitude bottom detection algorithm is used, in order to provide soundings with the best possible accuracy.

Acoustical seabed imaging

Integrated seabed acoustical imaging capability is included as standard. Software to use this data for automatic seabed classification is available.

Water column display

A real time display window for water column backscatter is available. Logging of water column data and of raw stave data (before beamforming) is a system option.

Choice of operator software

The EM 710 is delivered as a complete stand-alone seabed mapping system. The Operator Station, a high-performance PC work station, includes the necessary operator controls for setting up and running the system, data logging and system testing. The Seafloor Information System (SIS) by Kongsberg Maritime also includes an extensive set of graphical displays for data quality control, as well as system calibration and other tools which are required. SIS supports on-line real-time data cleaning to improve the overall survey efficiency.

Post-processing software for the EM 710 is available from both Kongsberg Maritime and third-party suppliers.

System drawing

Figure 1 EM 710 system units and interfaces

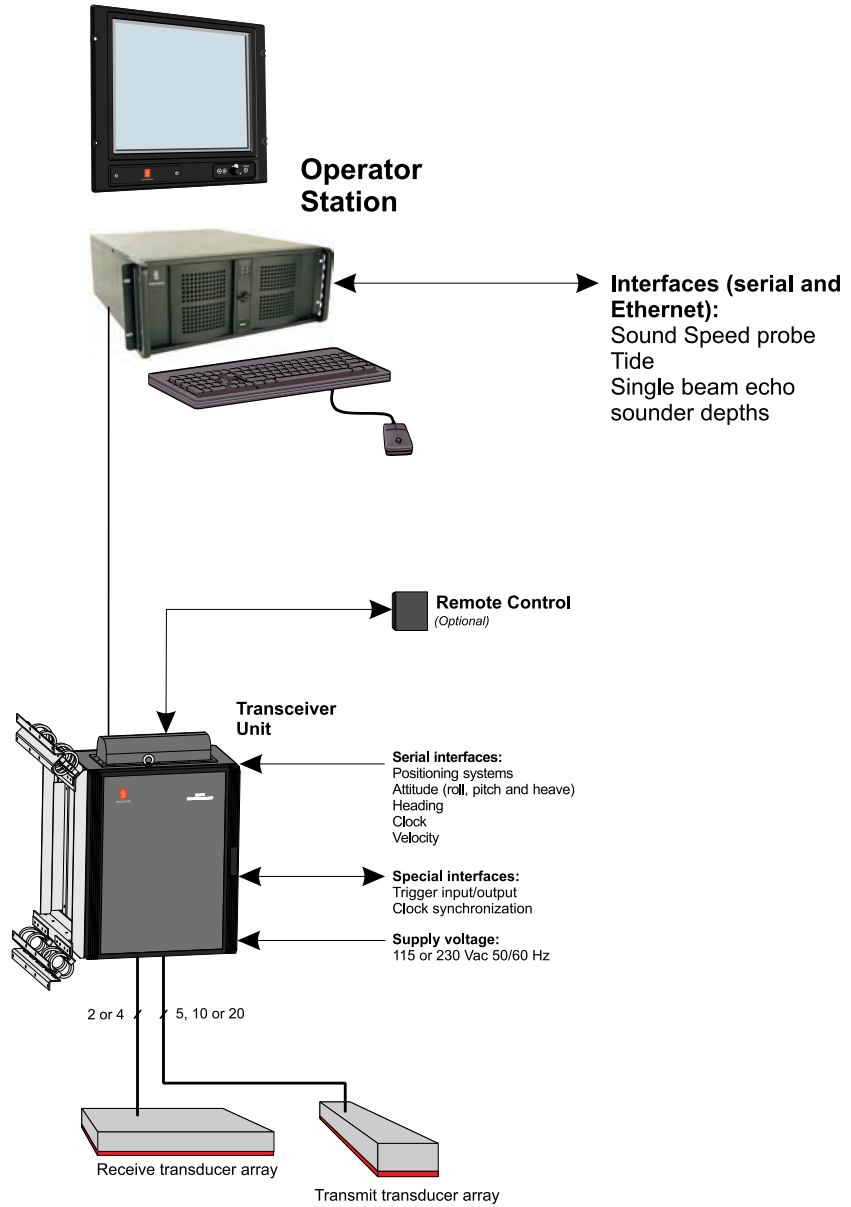

System configuration with desktop operator station, transceiver unit and transducer arrays.

1.4 System characteristics

Main units

The basic EM 710 multibeam echo sounder consists four units

- Transmit Transducer
- Receive Transducer
- Transceiver Unit
- Operator Station

A complete mapping system will in addition include a vessel motion sensor, heading sensor, sound velocity sensor(s) and a positioning system.

Transducers

The EM 710 transducers are fully water tight units intended for many years of trouble-free operation in rough seas. The transmit and receive transducers both have a width of 224 mm and a height of 118 mm. Their length depends upon the chosen beamwidth, either 970 mm for a 1 degree unit or 490 mm for a 2 degrees unit. The weights are respectively 35 and 18 kg (excluding cables).

The weight of a 0.5° x 1° system are 70 and 18 kg (excluding cables).

The transducers have a maximum depth rating of 250 m.

A transmit beamwidth of 0.5 degree is achieved by mounting two 970 mm transmit transducers together alongship. Such a beamwidth reduction is not possible with the receive transducer.

The transducers are supplied as standard with 15 m long underwater cables terminated with a surface connector directly pluggable into the Transceiver Unit. On special order underwater connectors or longer cables may be supplied. Five, ten or twenty cables are used on the transmit transducer, two or four on the receive transducer, in accordance with the transducer length.

Transceiver Unit

The EM 710 Transceiver Unit contains all transmit and receive electronics, and the Processing Unit which performs the beamforming, bottom detection, and motion and sound speed corrections. It contains all interfaces for time-critical external sensors such as vessel attitude (roll, pitch, heading and heave), vessel position and external clock. More than one sensor of each type may be connected simultaneously, with one in use but all logged.

The Transceiver Unit comprises two 19" sub-racks contained in a cabinet designed for bulkhead or deck mounting.

For the 2° x 2° system, the TRU are compressed in one 19" sub-rack.

The number of circuit boards will depend upon the chosen transducer configuration. Twisted pair Ethernet is used for data communication with the Operator Station.

Operator Station

The Operator Station of the EM 710 is the HWS high performance dual-processor PC workstation. The operator software is the Seafloor Information System (SIS). The HWS dual bootable to either Linux® or Windows XP®.

SIS, as a minimum, allows setting the EM 710 installation and runtime parameters, data logging and running self-test on the system without restrictions.

The SIS software also includes functionality for survey planning, 2D and 3D geographical display of the survey results, seabed image and water column displays, plus real-time data cleaning algorithms.

Alternatively, third-party software solutions can be used for the operator interface and real-time processing.

The HWS is normally supplied with a 19" industrialized LCD monitor with a resolution of 1280 x 1024 pixels. Support for a second monitor is included. A spill-proof US keyboard and a standard optical mouse is normally supplied, but optionally a small IP 65 rated keyboard with integrated track stick can be delivered.

1.5 Optional

For an optional dual system a maximum swath width of 10 x water depth in shallow water can be achieved. (200 degrees, 3000 m) In deeper water a maximum of 3 x water depth.

A dual system will generate twice as many beams/sounding. 512/800 per ping for a 0.5° and 1° system and 256/400 per ping for a 2° system.

1.6 General safety rules

The system operates on 115 and/or 230 Vac, 50/60 Hz with a switch in the Transceiver Unit.

WARNING

This voltage can be lethal.

The following safety precautions must be followed at all times during installation and maintenance work:

- Always switch off all power before installation or maintenance. Use the main circuit breaker, and label the breaker with a warning sign that informs others that maintenance or installation work is being carried out on the system.
- Read and understand the first aid instructions for electric shock.
- For safety reasons during troubleshooting on the equipment with power ON, two persons should always be present.
- Whenever maintenance is carried out, it is essential that a first aid kit is available, and that the maintenance personnel are familiar with the first aid instructions for electrical shock.
- The various parts of the system are heavy. Make sure that the appropriate tools and certified lifting equipment are available, and that the personnel are trained in installation and maintenance work.

2 TECHNICAL SPECIFICATIONS

Note

Kongsberg Maritime AS is engaged in continuous development of its products and reserves the right to alter specifications without prior notice.

Topics

- *Interfaces* on page 14
- *Physical specifications* on page 15
- *Power requirements* on page 16
- *Environmental and EMC specifications* on page 17
- *System performance data* on page 17

2.1 Interfaces

These interfaces are found on the Transceiver Unit and the Operator Station:

- Serial lines with operator adjustable baud rate, parity, data length and stop bit length for:
 - Motion sensor (roll, pitch, heave and optionally heading) in format supported by sensors from the main suppliers like Applanix , iXSEA, Coda, Kongsberg Maritime
 - Heading NMEA 0183 HDT, SKR82/LR60 or EM attitude format or Sperry Mk39 format
 - Positions in either Simrad 90, NMEA 0183 GGA or G GK format
 - External clock in NMEA 0183 ZDA format / Trimble UTC
 - Sound speed at transducer
 - Sea level height (tide)
 - Single beam echo sounder depths
 - Output of depth straight down in NMEA 0183 DPT format
- Interface for 1PPS (pulse per second) clock synchronisation signal
- SATA and Firewire interface for external data storage devices
- USB 2.0 interfaces for data storage, printing or plotting
- Parallel interface for Postscript colour graphics printer/plotter
- Ethernet interface for velocity input needed for Doppler compensation in chirp mode.
- Gigabit and Megabit Ethernet interface for input of sound speed profile, tide and echo sounder depths, and output of all data normally logged to disk.

2.2 Physical specifications

Transducer – 2 degrees

- **Length:** 490 mm
- **Width:** 224 mm
- **Height:** 118 mm
- **Weight:** 18 kg (nominal without cables)

Transducer – 1 degree

- **Length:** 970 mm
- **Width:** 224 mm
- **Height:** 118 mm
- **Weight:** 35 kg (nominal without cables)

Transducer – 0.5 degree (two 1 degree modules)

- **Length:** 1940 mm
- **Width:** 224 mm
- **Height:** 118 mm
- **Weight:** 70 kg (nominal without cables and mounting frame)

Transceiver Unit (version for bulkhead mounting)

- **Height:** 841 mm
- **Width:** 540 mm
- **Depth:** 750 mm (nominal including shock absorbers)
- **Weight:**
 - 106 kg (2 by 2 degrees)
 - 111 kg (1 by 2 degrees)
 - 116 kg (1 by 1 degree)
 - 127 kg (0.5 by 1 degree)

Note

A smaller Transceiver Unit is normally used for the 2 by 2 degrees model. See below

TRU compact – 2 x 2 degree system on page 25

Transceiver Unit – 2 x 2 degree system (version for bulkhead mounting)

- **Height:** 573 mm
- **Width:** 540 mm
- **Depth:** 750 mm (nominal including shock absorbers)
- **Weight:** 83 kg

Operator Station

- **Height:** 127 mm
- **Width:** 427 mm (excluding rack fixing brackets)
- **Depth:** 480 mm (excluding handles and connectors)
- **Weight:** Approximately 20 kg

19" inch LCD monitor

- **Height:** 444 mm (excluding mounting brackets)
- **Width:** 483 mm (excluding mounting brackets)
- **Depth:** 68 mm (excluding mounting brackets)
- **Weight:** 12 kg (approximately with bracket)

2.3 Power requirements

Operational voltage and frequency

- AC voltage: 115 (60 Hz) or 230 (50 Hz) Vac
Voltage $\pm 10\%$
Frequency $\pm 5\%$

Acceptable transients

- Short time (max. 2 sec) : $\pm 20\%$, 42 – 69 Hz
- Spikes (max. 50 μ s) : < 1000 V

Transceiver Unit

- 0.5° x 1°: < 800W
- 1° x 1°: < 600W
- 1° x 2°: < 500W
- 2° x 2°: < 400W
- The single phase supply must be protected with 16A (230 Vac supply) slow-blow fuses.
- **Operator Station:** < 250 W
- **LCD monitor:** < 60 W (max)
- **Remote Control:** None

Note _____

*For 115 Vac operation, please contact
km.hydrographic.support@kongsberg.com*

Power interrupts

Menu settings, all parameters and the sound speed profile are stored on the Operator Station's harddisk during operation, so operation can continue after power interruption. However, the file system may be damaged, so the use of an uninterruptable power supply (UPS) is highly recommended.

2.4 Environmental and EMC specifications

The system meets all requirements of the IACS E10 specification.

The Transceiver Unit meet the additional stronger requirements of the IEC 60945 specification.

The Operator Station and the LCD monitor are both IP22 rated. The Transceiver Unit is IP54 rated.

Environment

- Operating temperature, sonar room: -5 to 50° C for TRU and TD
- Operating temperature, operating room: +5 to 50° C for HWS
- Storage temperature: -30 to +70° C
- Humidity: 95% RH at 55°C , non-condensing

Humidity requirements will depend on customer requirements. Normal specification is up to 80% non-condensing.

Note

To extend the lifetime of the equipment, the sonar room should be equipped with sufficient ventilation and the temperature should not be too high (i.e. not > 30°C) for long periods of time.

Vibration

- 5 – 150 Hz, 1.23g rms
2 hours duration

Shock

- Cabinets w/shock absorbers: 15g half period sine pulse
- Duration: 11 ms

2.5 System performance data

- **Frequency range:** 70 to 100 kHz
- **Maximum ping rate:** 30 Hz

- **Number of beams and soundings for each ping:**
 - 1 x 2 and 2 x 2 degrees: 128 beams with 200 soundings in High Density mode per swath
 - 0.5 x 1 and 1 x 1 degree: 256 beams with 400 soundings in High Density mode per swath
 - With Dual swath the number of beams and soundings are doubled
- **Beamwidths:** 0.5 x 1, 1 x 2, 1 x 2 or 2 x 2 degrees
- **Beam spacing:** Equidistant, Equiangle, High Density
- **Coverage sector:** Up to 140 degrees
- **Transmit beam steering:** Stabilized for roll, pitch and yaw
- **Receive beam steering:** Stabilized for roll
- **Depth range from transducers:** 3 to approximately 2.000 metres
- **Depth resolution:** 1 cm
- **Pulse lengths:** 0.15, 0.5 and 2 ms CW and up to 120 ms FM
- **Range sampling rate:** 14 kHz (5 cm) at data output

3 CABLE LAYOUT

Note

For more detailed information about this chapter – see our installation manual for EM 710

Topics

- *System cabling* on page 20
- *Operator Station cables* on page 21
- *Transceiver Unit cables* on page 22
- *Transducer cables* on page 29
- *Cable specifications* on page 32

The standard cables used between the EM 710 system units and between the units and their external devices are shown here. For larger installations where the EM 710 is a subsystem, the cables will also be shown in the cable layout plan and interconnection diagram specific for the vessel into which the system is installed.

Note

All cable connections may have to be made in accordance with the guidelines laid down by the vessel's classification society.

Contact information:

DNV

Corporate Headquarters

Veritasveien 1

1322 Høvik Norway

<http://www.dnv.com>

3.1 System cabling

Cable layout

The interconnection cables are identified on the cable plan drawings. The following pages give a brief description of each cable. In the Drawing file, each cable is identified with the appropriate terminations and required specifications.

Shipyard and system cables

Each individual cable is identified on the cable plan. The cables fall into two categories:

- Cables provided by the installation shipyard or owner
- System cables supplied with the delivery

Shipyard cables

The cables that must be provided by the shipyard or owner are identified as such in the descriptions. Note that the cable specifications given are the minimum specifications.

For each cable, the following information is provided:

- Connection to be made on each end of the cable (including system unit, terminal board identification and plug/socket to be used)
- Number of cores
- Recommended cable type
- Minimum cable specifications

The appropriate considerations must be taken to suit special requirements. Kongsberg Maritime accepts no responsibility for damage to the system or reduced operational performance if this is caused by improper cabling.

System cables

Several cables will be supplied with the system. Such cables normally comprise power cables for peripheral equipment, and interconnection cables for computers and/or workstations. These cables will normally be delivered with the hardware.

Several cables will be supplied with the system. Such cables normally comprise power cables, and interconnection cables for computers and/or workstations. These cables will normally be delivered with the units.

3.2 Operator Station cables

The illustration and the list below specifies each cable used on the EM 710 Operator Station. References are made to detailed cable drawings in the EM 710 installation manual.

Note that this information includes several cables that may not be in use on all installations.

Figure 2 Operator Station cables

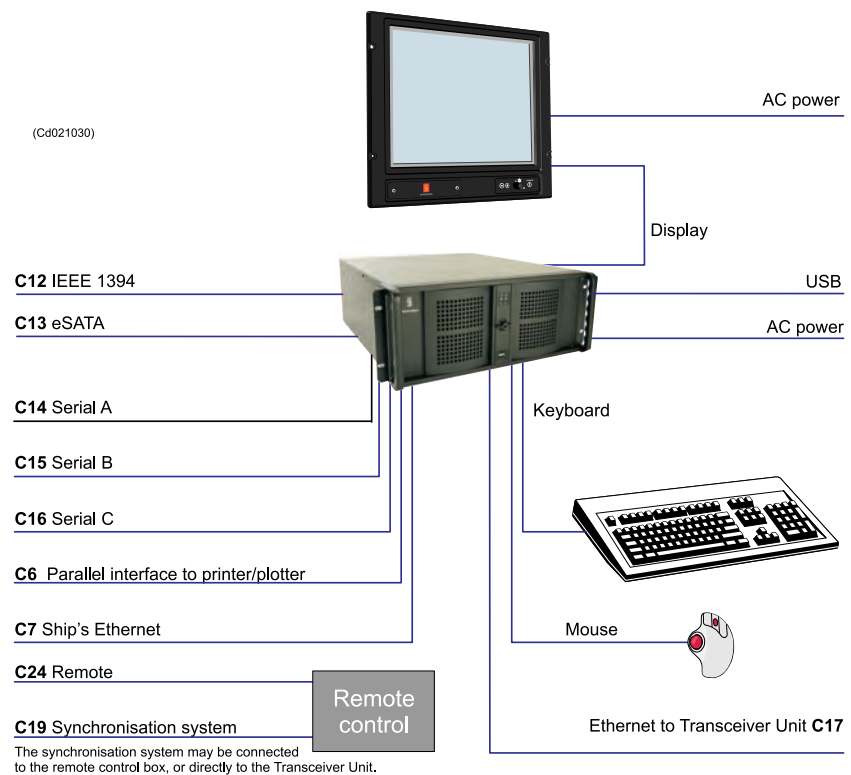

3.3 Transceiver Unit cables

The illustrations and the cable lists below specify each cable used on the EM 710 Transceiver Unit. References are made to detailed cable drawings.

Note that this information includes several cables that may not be in use on all installations.

Figure 3 Transceiver Unit - overview of interfaces

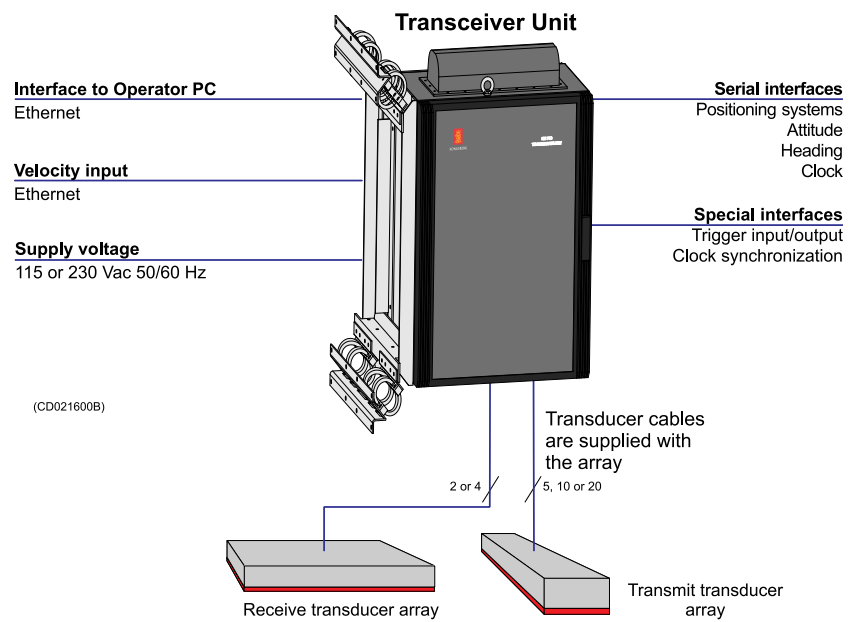

Internal cabling made at the factory:

- 1 Front side:
 - Ethernet cables that connects the different plug in boards.
- 2 Rear side:
 - One control signal cable between sub-racks
 - AC power cables between the sub-racks

3.3.1 Transceiver Unit – front view

Figure 4 0.5 x 1 degree

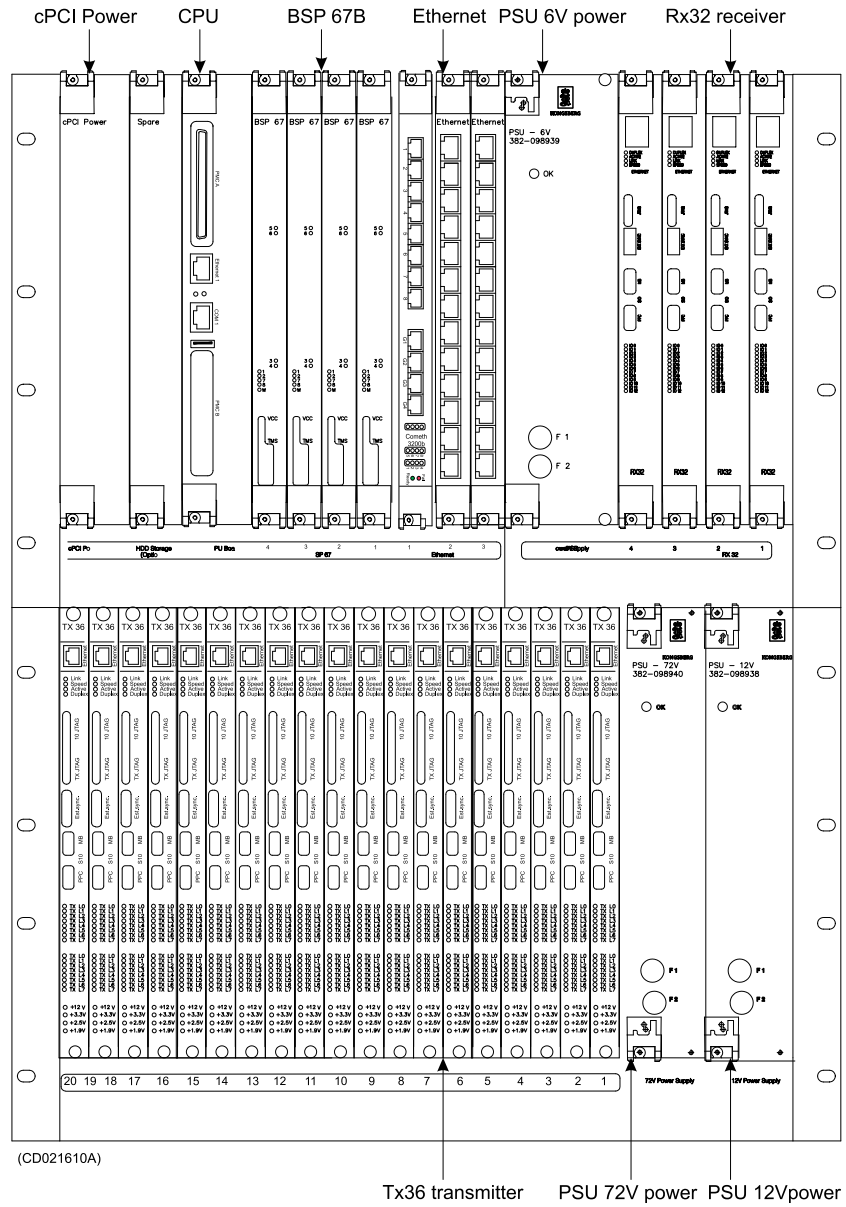

3.3.2 Transceiver Unit – rear view

Figure 5 0.5 x 1 degree

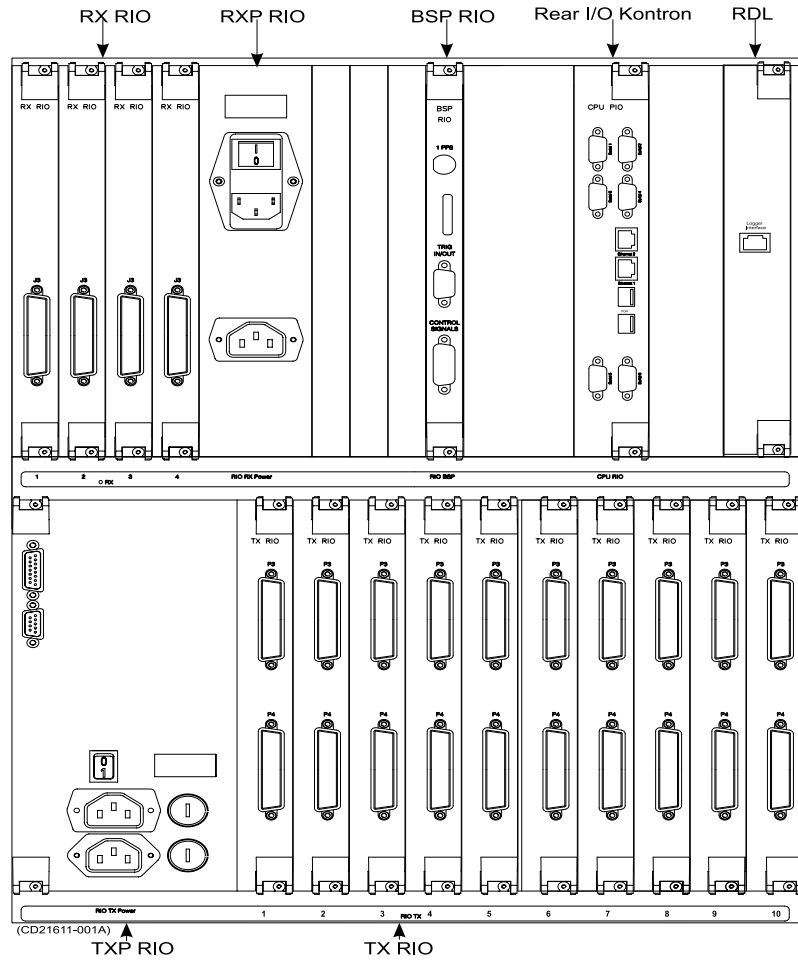

3.3.3 TRU compact – 2 x 2 degree system

Note

All cards used in 2 x 2 degree system are the same as shown in 0.5 x 1 degree system.

Figure 6 Transceiver Unit front view – 2 x 2 degree

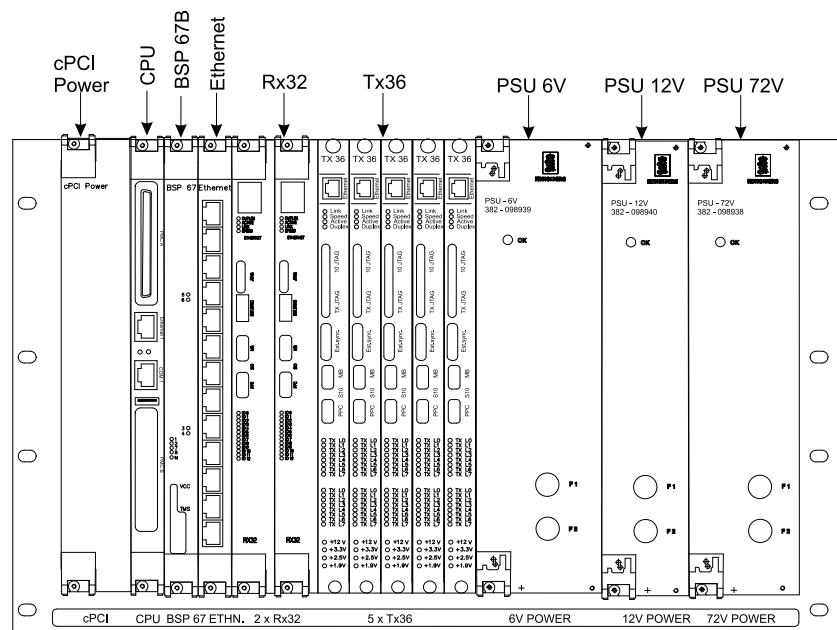

(cd021661-001)

Figure 7 Transceiver Unit rear view – 2 x 2 degree

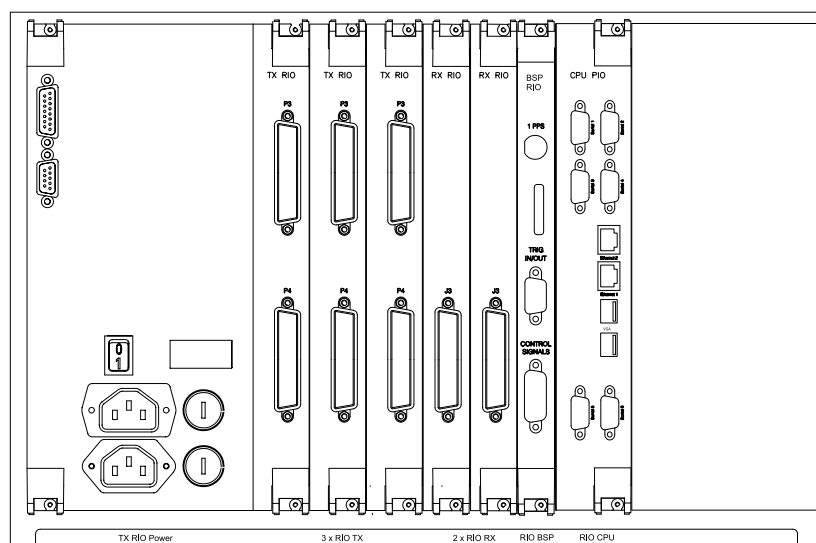

(CD021661-002)

Figure 8 Cable configuration for 2 x 2 degrees system

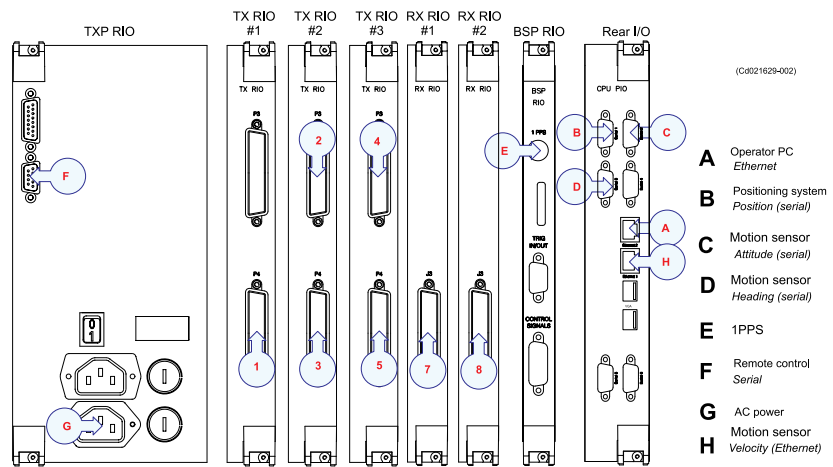

- 1 - 5 – Connection between TRU and TX array
- 7 - 8 – Connection between TRU and RX array

3.3.4 Transceiver Unit – Cable configuration

This chapter presents a standard cable configuration for a complete EM 710 echo sounder system. The following illustrations describe a 0.5 x 1 degrees model, but note that the actual cable layout will be different for every system, depending on the EM 710 model, the number of external sensors and other interfacing systems.

Figure 9 0.5 x 1 degree system cabling between TRU and other system units and external systems

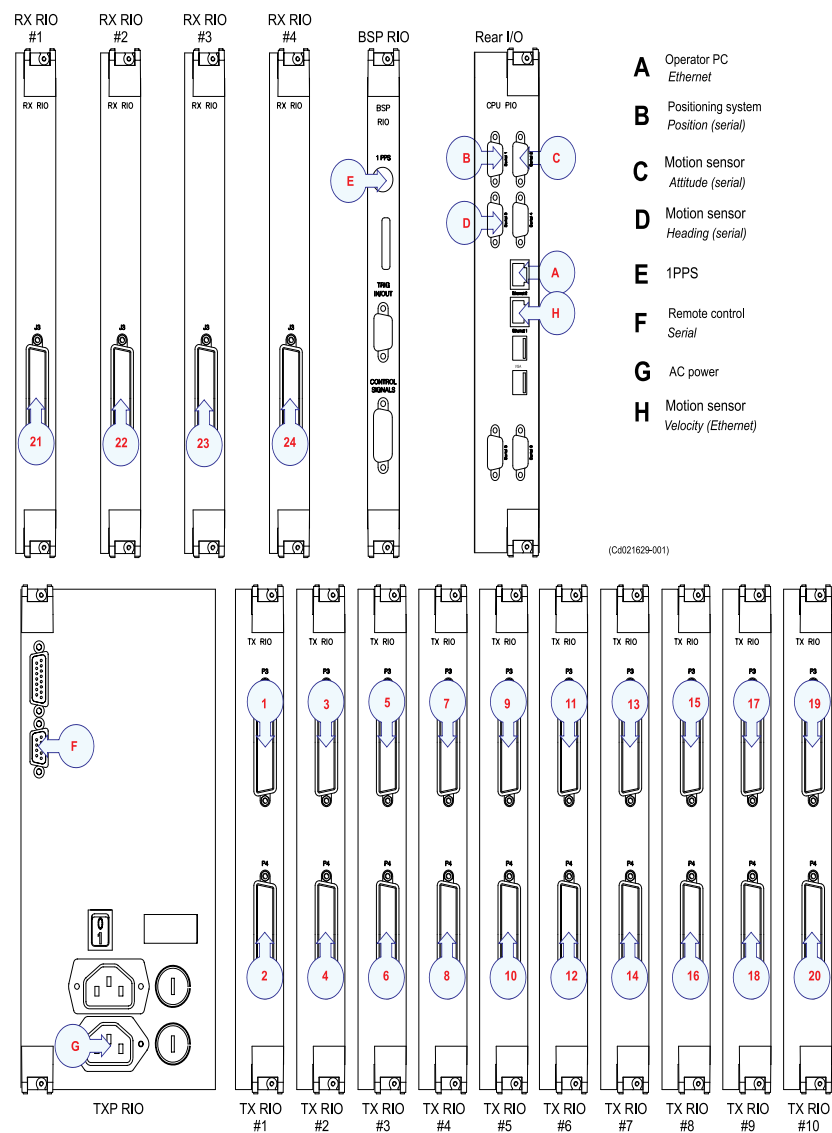

- 1 - 20 – Connection between TRU and TX array
- 21 - 24 – Connection between TRU and RX array

Figure 10 Internal cabling in the Transceiver Unit (power and control cables)

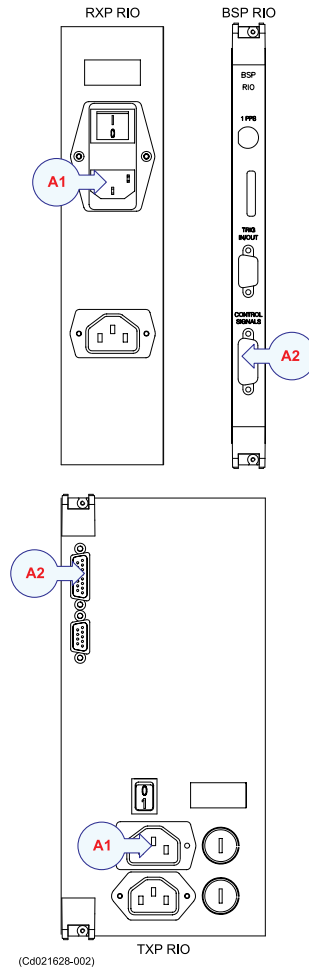

- **A1** – Connection between RXP RIO and TXP RIO (AC power)
- **A2** – Connection between BSP RIO and TXP RIO (control signals)

3.4 Transducer cables

The transducer cables between the transducer arrays and the Transceiver Unit are all supplied by Kongsberg Maritime with the EM 710 system. The physical number of cables depends on the chosen system beamwidth as shown the following tables.

System beamwidth (TX x RX)	Number and type of TX transducer modules	Number and type of RX transducer modules
	Number of cables from TX transducer array to Transceiver Unit	Number of cables from RX transducer array to Transceiver Unit
0.5 x 1 degree	2 x TX1	1 x RX1
	20	4
1 x 1 degree	1 x TX1	1 x RX1
	10	4
1 x 2 degrees	1 x TX1	1 x RX2
	10	2
2 x 2 degrees	1 x TX2	1 x RX2
	5	2

The following cable information is available both in the EM 710 installation and maintenance manuals. The cable markings are normally recorded in the installation manual first, and it is recommended to copy these records to the maintenance manual later.

Note that performance data about each element and its serial number are recorded in the Factory Acceptance Test documentation provided with each system.

3.4.1 Transmit array cable markings

The TX transducer module(s) and its cable is identified as follows:

TX1<m>/<n> or TX2<m>/<n> where <m> is the cable number (a number between 1 and 10) and <nnn> is the module's serial number (a numerical value).

The transducer cables are moulded to the TX array, but connect in the other end to the Transceiver Unit (TRU) with 76-pin D-sub connectors.

Note

During the installation of the TX array, you must fill in the cable identification table(s) below.

For a 0.5 x 1 degree system, you will need all cables listed in the tables. With a 1 x 1 or 1 x 2 degrees system, you only need the first 10, while the 2 x 2 degrees system only requires the first 5 cables.

The 0.5 x 1 degree system consists of two TX modules. It is essential to connect all 20 TX cables successively to the TX RIO boards in the Transceiver Unit. Where to start is determined by the physical orientation of the transducer cable outlet (port or starboard). Both options are shown in the figure below.

Figure 11 Connection of TX transducer cables, 0.5 x 1 degree system

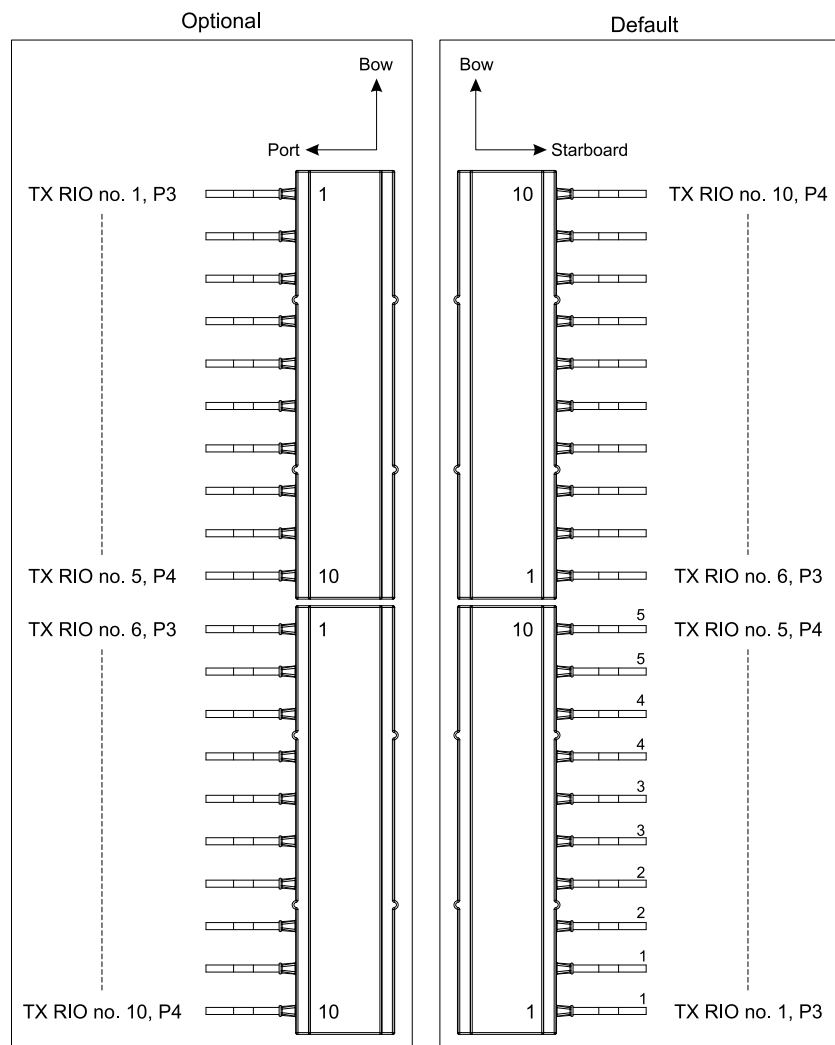

Table 1 Connection of TX transducer cables

TX array identification		TRU identification	
Cable no.	Serial no.	TX RIO no.	Socket no.
1		1	P3
2		1	P4
3		2	P3
4		2	P4
5		3	P3
6		3	P4
7		4	P3
8		4	P4
9		5	P3
10		5	P4

Table 2 Connection of TX transducer cables

TX array identification (second 0.5 degree array)		TRU identification	
Cable no.	Serial no.	TX RIO no.	Socket no.
1		6	P3
2		6	P4
3		7	P3
4		7	P4
5		8	P3
6		8	P4
7		9	P3
8		9	P4
9		10	P3
10		10	P4

Table 3 Connection of TX transducer cables with TRU compact – 2 x 2 degree system

TX array identification		TRU identification	
Cable no.	Serial no.	TX RIO no.	Socket no.
			P3
1		1	P4
2		2	P3
3		2	P4
4		3	P3
5		3	P4

3.4.2 Receive array cable markings

The RX transducer module(s) and its cable is identified as follows:

RX1<m>/<n> or **RX2<m>/<n>** where <m> is the cable number (a number between 1 and 10) and <n> is the module's serial number (a numerical value).

The transducer cables are moulded to the RX array, but connect in the other end to the Transceiver Unit (TRU) with 76-pin D-sub connectors.

Note _____

During the installation of the RX array, you must fill in the cable identification table below.

In a 0.5 x 1 or 1 x 1 degree system, you will need all cables listed in the table. With a 1 x 2 or 2 x 2 degrees system, you only need the first 2 cables.

RX array identification		TRU identification
Cable no.	Serial no.	RX RIO no.
1		1
2		2
3		3
4		4

3.5 Cable specifications

The Drawing file chapter provides detailed information about the cables used in the system. Note that several cables may share identical specifications.

The technical parameters provided for the cables are the minimum specifications. Also, in most cases, it may be useful to install extra pairs in selected cables for future expansions.

Note _____

The cables specified may not meet the standards provided by the vessel's classification society. Consult the applicable guidelines.

Kongsberg Maritime as takes no responsibility for performance degradation or damage caused to system, vessel or personnel if the cables used during installation do not meet these specifications.

4 OPERATOR STATION

The HWS Hydrographic Work Station is the operator station normally used with the EM 710 Multibeam echo sounder.

This is a basically a PC work station, but it has been specially designed for rugged maritime use, and it is prepared for mounting in a standard 19" rack. In the rack it will require four rack height units. The HWS is by default supplied with at 19" industrial LCD monitor, a keyboard and an optical mouse. The display monitor can be mounted in a 19" rack, however a bracket for table, bulkhead or roof mounting is provided.

Figure 12 HWS Hydrographic Work Station



All components making up the HWS Hydrographic Work Station are standard commercial computer parts.

4.1 HWS overview

The primary task of the HWS Hydrographic Work Station is to safeguard the collected data and to visualize it for quality control. The computer is equipped to handle the heavy processing requirements and the high speed, large volume data storage demands of hydrographic systems. It has been specifically designed as the optimal platform for running the Seafloor Information System (SIS) real-time operating software used on the Kongsberg Maritime EM multibeam echo sounders.

The special features of SIS include real-time:

- Gridding of sounding data
- Filtering of sounding data
- 3-D visualization of sounding data
- Storage and visualization of high resolution backscatter data from the seabed and the water column

The partitioned system disk is by default provided with two operating systems; Linux and Microsoft Windows XP®. During the computer's boot sequence up you can decide which operating system to use. The Seafloor Information System (SIS) software is factory installed and tested on both operating systems.

4.2 Technical description

The primary task of the HWS Hydrographic Work Station is to safeguard the collected data. All data are thus initially stored on a pair of high performance SATA disks. These disks are run in a RAID1 configuration, thus ensuring against loss of data even if one disk should fail. They are mounted in "hot swappable" enclosures, so that the collected data may be transported on the disk.

A DVD recorder is the standard means for permanent archiving of the collected data.

If you wish to use other storage devices or media, the HWS provides USB 2.0, Firewire (IEEE 1394) and SCSI interfaces. Gigabit Ethernet interface is available for transfer of the data to another network computer. For temporary storage data may also be backed up to the system drive.

4.3 HWS circuit boards and modules

The HWS Hydrographic Work Station comprises commercial circuit boards and modules.

5 TRANSCEIVER UNIT

The EM 710 Transceiver Unit contains all transmit and receive electronics. It comprises one or two 19" sub-racks contained in a cabinet designed for bulkhead or deck mounting.

- 1 The upper **Receiver rack** holds the receiver boards, circuit boards for processing, beam forming and communication and two power supplies
 - The lower **Transmitter rack** holds the transmitter boards and two power supplies
- 2 For a 2° x 2° system there is two ways to compose this system:

One as described above or one using a single 19" sub-rack containing both **Receiver** and **Transmitter** system units.

Both sub-racks are equipped with high efficiency fans. The filtered air inlet is at the bottom of the Transceiver Unit, and the outlet is at the top.

The Transceiver Unit is mounted on shock and vibration dampers. This chapter provides the following information:

5.1 Theory of operation

Overview

This chapter presents a functional description of the EM 710 Transceiver Unit.

Simplified block diagram

The simplified block diagram for the Transceiver Unit presents the following main functions.

- Processing
- Transmission
- Reception

The commands and parameters from the SIS operator station are sent via the Ethernet connection to the Control processor (CPU) in the TRU.

The CPU contains a DiskOnModule where the software is stored. New releases of the software can be downloaded from the Operator Station.

For control of the transmitters the commands and parameters are interpreted and passed on through an Ethernet interface to the transmitter boards (TX36). The control processor at each TX36 board uses the received parameters to calculate the individual steering of each transmitter. The boards have power amplifiers used for the analog output signals. These signals are sent via the rear I/O module (TX RIO) and a junction box to the TX array. The high voltage is made by a high voltage power supply. A capacitor bank on the TX RIO boards is used to store the energy needed for the TX pulses.

The RX array is connected directly to the TRU rear I/O modules (RX RIO).

The CPU downloads parameters through an Ethernet interface to the receiver boards (RX32). The RX32 processors control the data acquisition. The stave data are amplified, digitized and bandpass filtered. The stave data are then passed to the BSP 67B board via the backplane.

The BSP 67B boards perform band the pass filtering needed for the different TX sectors, and the beam forming of all the receiver beams. The beam data are transferred to the CPU board via the cPCI bus.

The CPU board performs the bottom detection and produces the output datagrams. It also reads the sensor data (time, position, attitude etc.) input from the RS-232 serial lines. The serial lines are connected via the rear I/O board and a serial PMC module mounted on the CPU board. The velocity data is read via a separate Ethernet line. The sound speed profile and the sound

speed at transducer depth are received from the operator station. The CPU puts a timestamp on all datagrams. The datagrams are sent via Ethernet to the operator station.

An Ethernet output is available for raw hydrophone data. A raw data logger can be connected to this output.

Figure 13 Transceiver Unit – simplified block diagram

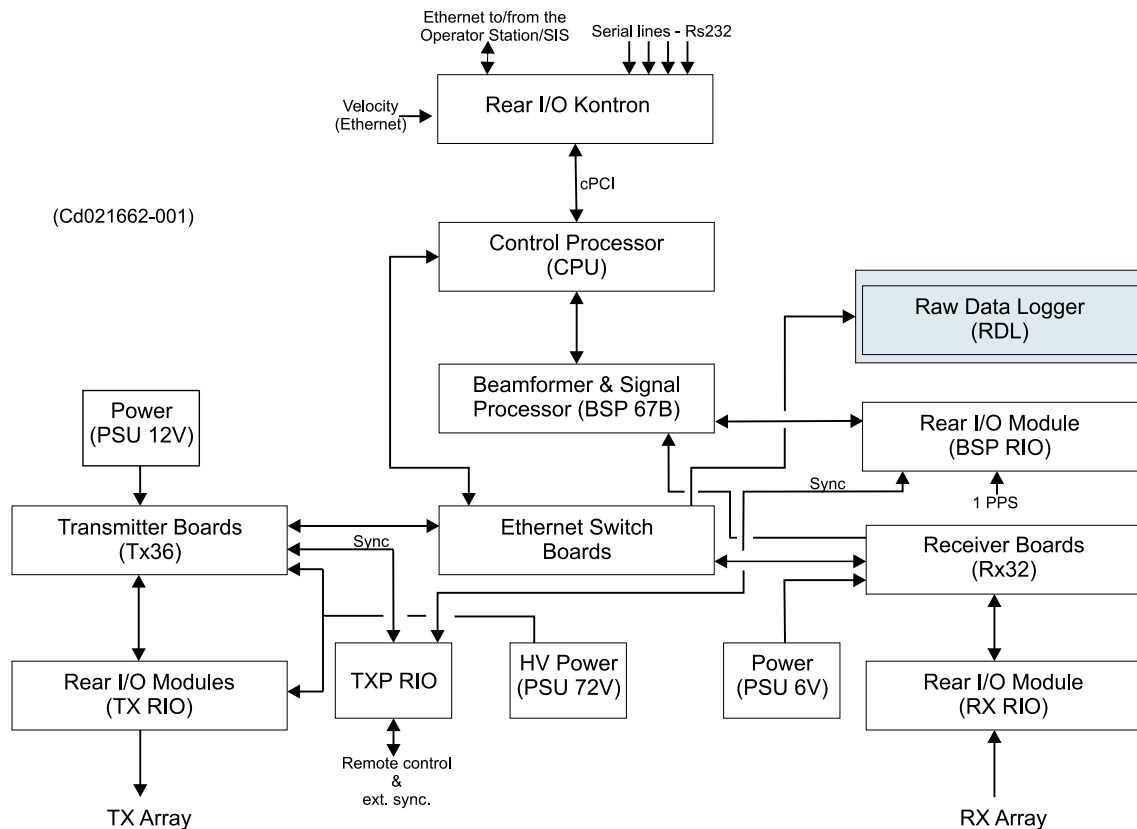

5.1.1 External synchronisation and remote on/off

The RS 232 serial line type RTS and CTS signals are used for external synchronisation. In addition a trig out signal is issued by the TRU.

The signals are available on the plug marked remote on the TXP RIO.

Table 4

Signal	Levels	Function	TRU remote plug
CTS (TRU input)	H=high= +3 to +15 V L=low = -3 to -15 V	H: Ping command to TRU L: Wait	Pin 8
RTS (TRU output)	H=high= +3 to +15 V L=low = -3 to -15 V	H: TRU is ready for a new ping L: TRU is busy	Pin 7
CTS/RTS gnd			Pin 6
Trig out (TRU output)	TTL Level	H: TX is off L: TX is active	Pin 1
Trig gnd			Pin 2

For cable details, see *Remote control and external trig* on page 129

Figure 14 Typical sequence

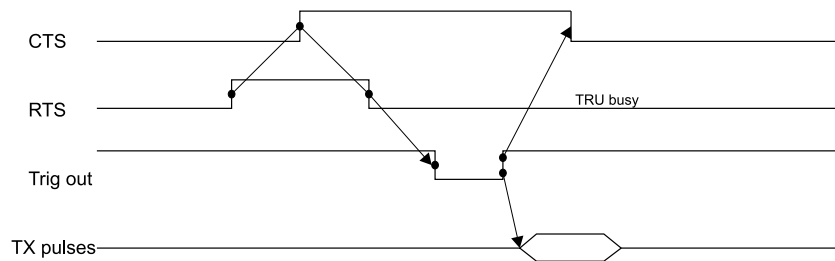

(cd021101-005)

When the TRU is ready for a new ping, RTS is set to H. When the external device is ready for a new ping, CTS shall be changed to H. The CTS must be high for minimum 100 microseconds. The TRU will then change RTS to L (busy), issue a Trig out signal (will be low for 1 millisecond) to indicate the start of the transmit pulses, and then transmit the TX pulses. After the Trig out is received, the external device should turn CTS back to L. When the receive period is finished and the TRU is ready for a new ping, the RTS will be changed to H, and the TRU will wait for a new trigger (a high level on CTS). If CTS is H all the time, or if external sync in the installation menu is switched off, the TRU will ping at its maximum rate.

Remote on/off

The TRU on/off function can be remotely controlled. The TRU is turned on by connecting pin 4 and 5 in the TRU remote plug together.

Trigger in/out (not used) on page 127

5.1.2 Clock sync 1 PPS

The 1 PPS (one pulse per second) signal is connected to the coax connector on the BSP RIO board. The BSP RIO is equipped with an optocoupler at this input. The input series resistor is tuned for a TTL signal (Low level < 0.6 V, High level > 3.2 V). The falling edge of the signal is used by the TRU to synchronize the internal clock. The 1 PPS signal must be minimum 1 microsecond long.

5.2 Receiver rack (large TRU)

The Receiver rack is the upper sub-rack of the Transceiver Unit. It holds several circuit boards and power supplies. All the units are accessed either from the front or the rear of the rack.

The Receiver rack contains an 84 HP backplane allowing circuit boards and modules to be inserted from both sides. Two different sizes of 6U boards are used (depths 160 and 220 mm). All circuit boards are supported by guide rails. The rack also contains two high efficiency fan units.

Figure 15 Receiver rack front view – 0.5 x 1 degree

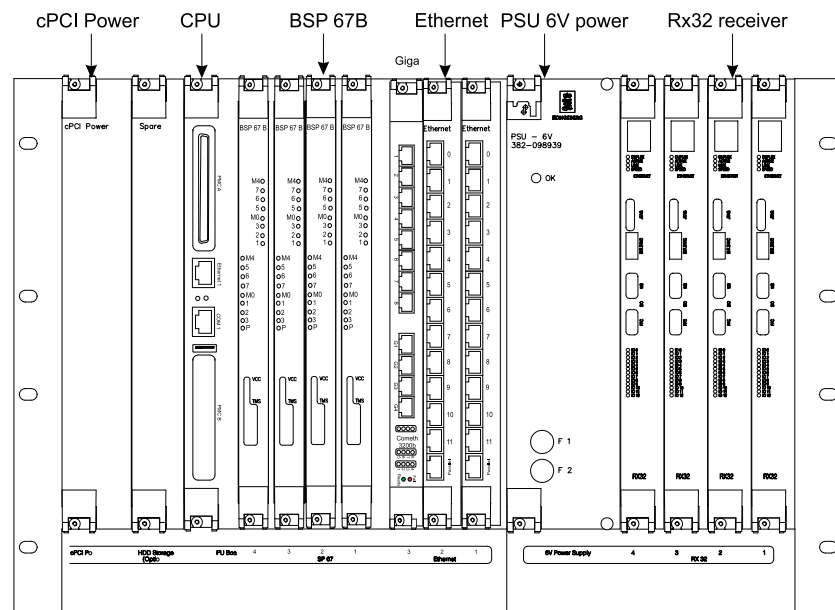

The Receiver rack holds the following front mounted circuit boards and modules (from left) :

- cPCI Power Supply
- CPU Board
- BSP 67B Boards
- Ethernet Switch Boards
- Power Supply PSU 6V
- RX32 Receiver Boards

Figure 16 Receiver rack rear view – 0.5 x 1 degree

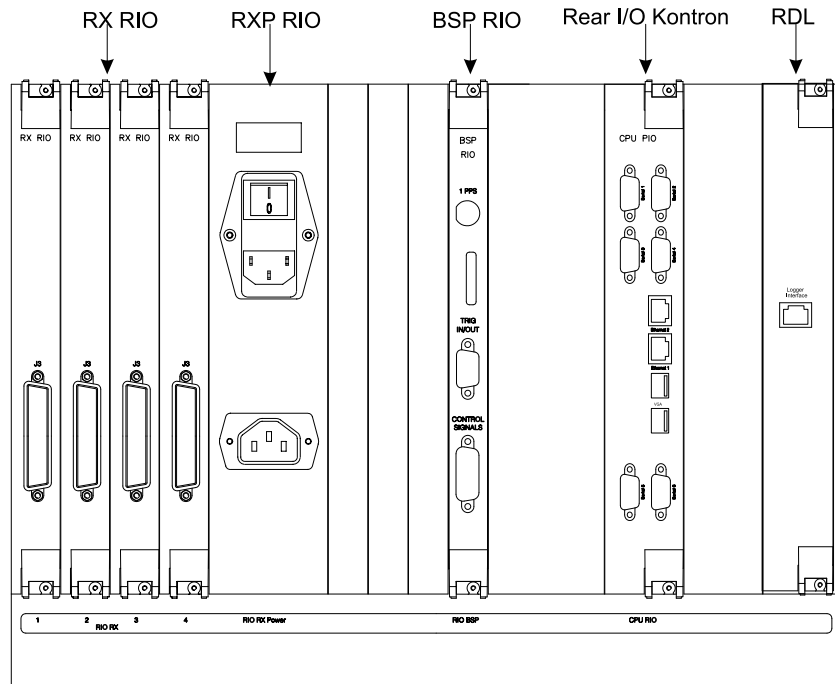

The following circuit boards and modules are rear mounted (from left) :

- RX RIO Rear Interface Boards
- RXP RIO Rear Interface Module
- BSP RIO Rear Interface Board
- Rear I/O Interface Board
- RDL

The illustrations above display the typical circuit board configuration for a 0.5 x 1 degree system. The number of boards used in the Transceiver Unit is different for each EM 710 model. For the Receiver rack, this is indicated by the table below.

Table 5 RX rack

RX rack	No. of items			
	0.5 x 1	1 x 1	1 x 2	2 x 2
Circuit boards				
cPCI Power Supply	1	1	1	1
CPU Board	1	1	1	1
BSP 67B Board	4	4	2	2
Ethernet Switch Board Giga	1	1	1	0
Ethernet Switch Board Mega	2	1	1	1
Power Supply PSU 6V	1	1	1	1
RX32 Receiver Board	4	4	2	2
RX RIO Rear Interface Board	4	4	2	2

Table 5 RX rack (cont'd.)

RX rack	No. of items			
	0.5 x 1	1 x 1	1 x 2	2 x 2
Circuit boards				
RXP RIO Rear Interface Module	1	1	1	1
BSP RIO Rear Interface Board	1	1	1	1
Rear I/O Interface Board	1	1	1	1
RDL	1	1	1	0

5.3 Transmitter rack

The Transmitter rack is the lower sub-rack of the Transceiver Unit. It holds several circuit boards and power supplies. All the units are accessed either from the front or the rear of the rack.

The Transmitter rack contains an 84 HP backplane allowing circuit boards and modules to be inserted from both sides. The front mounted modules are all 6U deep (220 mm) and the rear modules have a standard depth of 80 mm. All circuit boards are supported by guide rails. The rack also contains a high efficiency fan unit.

Figure 17 Transmitter rack front view – 0.5 x 1 degree model

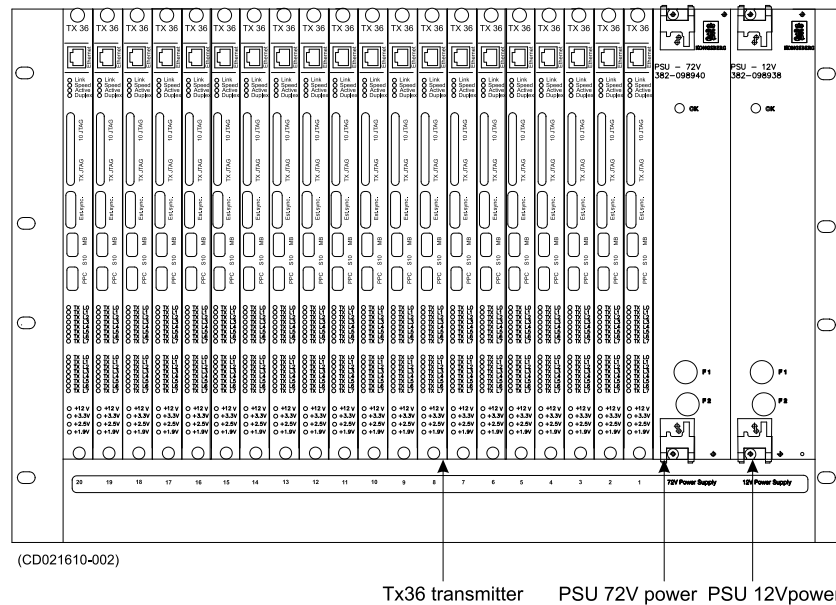

The Transmitter rack holds the following front mounted circuit boards and modules (from left) :

- TX36 Transmitter Board
- Power Supply PSU 72V
- Power Supply PSU 12V

Figure 18 Transmitter rack rear view – 0.5 x 1 degree model

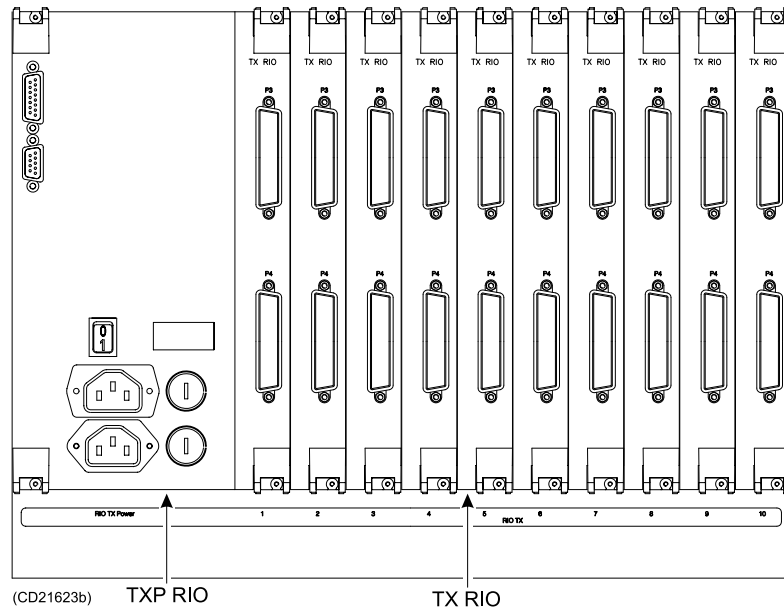

The following circuit boards and modules are rear mounted (from left) :

- TXP RIO Rear Interface Board
- TX RIO Rear Interface Boards

The illustrations above display the typical circuit board configuration for a 0.5 x 1 degree system. The number of boards used in the Transceiver Unit is different for each EM 710 model. For the Receiver rack, this is indicated by the table below.

Table 6 TX rack

TX rack	No. of items			
	0.5 x 1	1 x 1	1 x 2	2 x 2
Circuit boards				
TX36 Transmitter Board	20	10	10	5
Power Supply PSU 72V	1	1	1	1
Power Supply PSU 12V	1	1	1	1
TXP RIO Rear interface board	1	1	1	1
TX RIO Rear interface board	10	5	5	3

5.4 TRU compact 2 x 2 degree system

This system contains one sub-rack with Processing, Receiver and Transmitter in one. It holds several circuit boards and power supplies. All the units are accessed either from the front or the rear of the rack.

Please note that the Giga ethernet switch board is not in use here.

Figure 19 Transceiver Unit front view – 2 x 2 degree

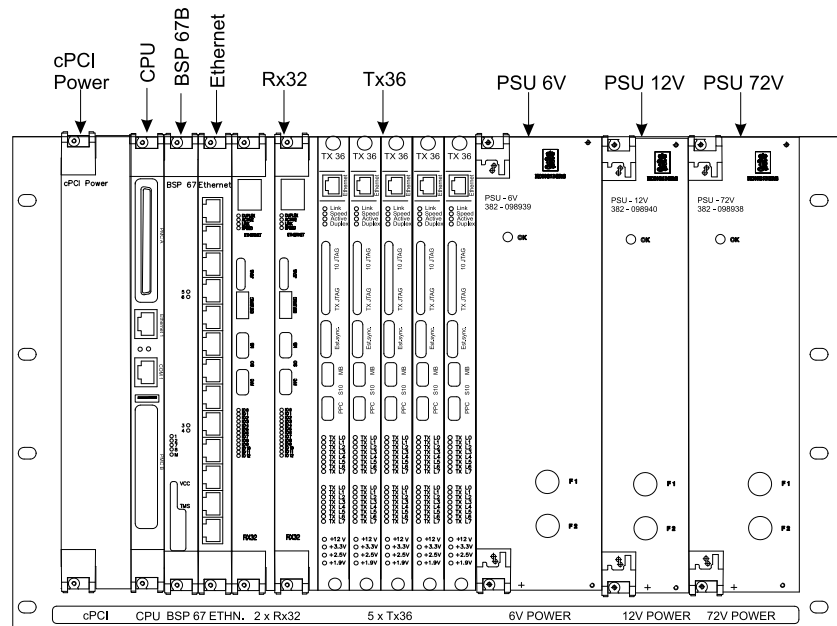

(0021661-001)

Figure 20 Transceiver Unit rear view – 2 x 2 degree

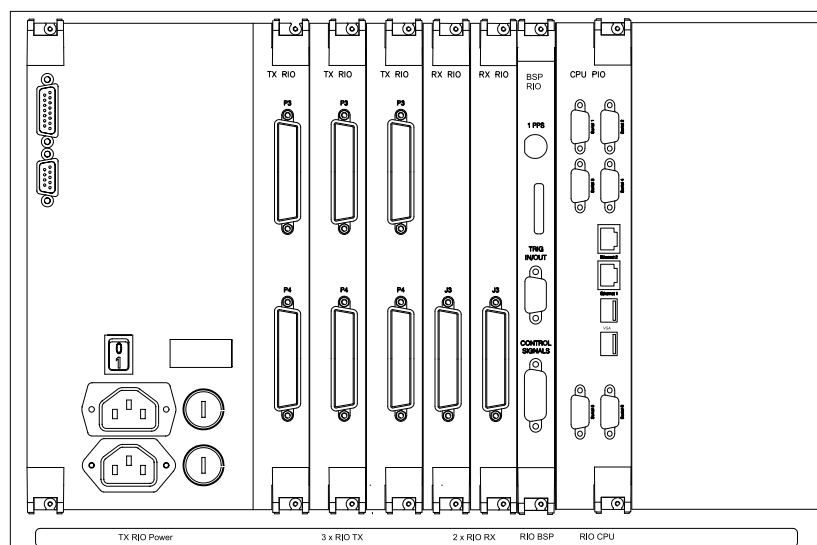

(CD021661-002)

5.5 Circuit board descriptions

In the following all the circuit boards and modules in the EM 710 Transceiver Unit are described. All facilities useful for maintenance personnel are provided.

5.5.1 cPCI Power Supply

Purpose and description

This is a standard 500 W cPCI Power Supply. Its main purpose is to supply DC output to the CPU, BSP 67B, RX32 and Ethernet Switch circuit boards.

Figure 21 Power One



Key features

- PICMG 2.11 compatible
- AC input
- Industry standard
- Power factor corrected
- Active current share
- International safety approvals

Specifications

Input:

- Input voltage: 90 to 264 Vac, 47 to 63 Hz
- Maximum input current: 7.1 A /90 Volt
- Inrush current: 30 A at 120 Vac, 20 A at 240 Vac
- Power factor: 0.95

Output:

- Output voltage and current ratings

Table 7

Output voltage (Vdc)	Maximum output current (A)
3.3	60.0
5.0	50.0
12.0	12.0
-12.0	4.0

- Line regulation: $\pm 10\text{mV}$

- Load regulation: $\pm 10\text{mV}$

General

- Efficiency: 80% minimum at 110 Vac
- Isolation: Input to ground 500 Vac, input to output 1500 Vac

Facilities

There are two front panel LEDs

LEDs:

- Green: Power good
- Amber: Power fail

External connections

- None.

5.5.2 CPU Board with PMC Module

Purpose and description

The Kontron CP6011 cPCI Single Board Computer is a fully IBM-AT compatible stand-alone PC. It is used by the Transceiver Unit as the Central Processing Unit (CPU). The TPMC866 is a standard single-width 32 bit PMC module. It has eight channels of high performance RS-232 serial ports with front I/O and back I/O. It is mounted on the CPU Board.

Figure 22 CPU Board

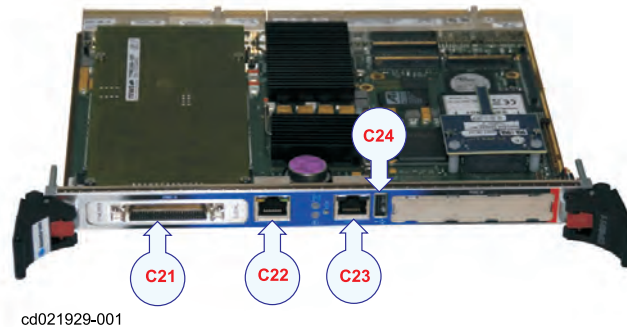

Key features

- Intel® Pentium M processor, 1.8 GHz
- FlashDrive, 512 Mb
- PCI Mezzanine Card (PMC) Interface

Specifications

Input

- Supply voltage : +3.3 Vdc, +5 Vdc, +12 Vdc, -12 Vdc
- Current (max): 6.1 A at 3.3 Vdc, 5.6 A at 5 Vdc, 0.3 A at 12 Vdc, <10 mA at -12

Vdc

- Power consumption: 43 W maximum

Capability

- DRAM: 512 MB SDRAM with ECC. Running at 200 MHz
- Chipset: Intel E7501 and Intel ICH3-S south bridge

- CMOS RAM: 114 byte non-volatile RTC, MC146818 compatible
- RTC with on-board Lithium battery

Facilities

There are two front panel LEDs

LEDs

- Blue: Hot swap Green: Power OK
- Green: Flash disk activity

External connections

- **C21 - PMC I/O Interface (TPMC866–10) – not used**

The TPMC866–10 cable is equipped with a 50-pin connector.

- **C22 - Ethernet**

The Ethernet cables are equipped with standard RJ-45 connectors. The CPU board has one Ethernet port (ETH1) in the front.

C22 connects to ETH1 for communication with one of the Ethernet Switch Boards. The cable C22 is provided by the manufacturer, and it is a part of the internal cabling

For cable details, see *Ethernet cable with RJ45* on page 131

- **C23 - Serial line (COM1) — not used**

This is a serial line terminated in a RJ 45 connector. COM1 is software selectable for RS-232 or RS-422/485 operation.

- **C24 - USB — not used**

The USB cable is equipped with a standard USB2 connector. One USB channel is available at the front panel of the CPU board. This cable is normally not used.

5.5.3 Kontron CP 6011 pentium CPU BOARD

Bios settings

Date

Time

- Legacy diskette A: Disabled
- Primary Master: Auto Shown as 261 MB
- Primary Slave: None
- Secondary Master: None
- Secondary Slave: None
- POST Errors Disabled
- System Memory 624 KB
- Extended Memory 511 MB

Advanced

Boot Settings Configuration

- Installed O/S Other
- Enable ACPI No
- Reset Configuration Data No
- Boot-time Diagnostic Screen Enabled
- Extended Memory Testing None
- Summary Screen Delay None
- Save CMOS in FLASH Enabled
- Retry Boot Sequence Disabled
- PS/2 Mouse Disabled
- SMART Device Monitoring Disabled
- Floppy Check Disabled

PCI Configuration – On-board Ethernet Controller

- On-board Ethernet Controller 1 Enabled
 - Option ROM Scan Disabled
- On-board Ethernet Controller 2 Enabled
 - Option ROM Scan Disabled
- On-board Ethernet Controller 3 Enabled
 - Option ROM Scan Disabled

PCI Configuration – On-board PMC Expansion

- On-board PMC A Expansion Slot
 - Option ROM Scan Enabled
 - Latency Timer Default
- On-board PMC B Expansion Slot
 - Option ROM Scan Enabled
 - Latency Timer Default

PCI Configuration – PCI Performance Settings

- PCI Cache Line Size 16
- On-board HB8 PCI-X Bridge Settings
 - Force 64 bit Control Both
 - Smart Prefetch Mechanism Enabled
 - Smart Prefetch Timeout 256 PCICLK
 - Prefetch scheme Aggressive
 - PCIX Pimary Initial Prefetch Count 8
 - PCI Sec. Initial Prefetch count 8
 - PCI Sec. Incremental Prefetch count None
 - PCI Sec. Maximum Prefetch count 32
- Default Primary Video Adapter On-board
- Delay before PCI Initialization 0
- IDE - Device 31, Function 1 Enabled
- Legacy USB Support Enabled

On-board Device Configuration

- Serial port A Enabled
 - Base I/O address 3F8
 - Interrupt IRQ 4
- Serial port B Enabled
 - Base I/O address 2F8
 - Interrupt IRQ 3
 - Mode RS-232
- Floppy Disk Controller Disabled

Advanced Chipset Control

- ECC Config ECC

Console Redirection

- Console Redirection Disabled
- N/A

Advanced Processor Options

- Speed Step Support POM

Monitoring**Intelligent System Monitor**

- Interrupt Generation Disabled
- Hardware Monitor Temperature **Read Temperature**
- Hardware Monitor Voltage Inputs **Read Voltages**

Control Temperature Events

- CPU Temperature Interrupt Disabled
- N/A

Control Voltage Events

- XXXX Interrupt **Disable All**

IPMI System Management

- N/A
- IDE Activity LED IDE Activity
- Watchdog After POST Disabled
- FPGA IRQ Disabled
- Automatic TCC Disabled
- Delay Prior to enabling the TCC N/A

Boot

- CD-ROM Drive
- Hard Drive
- Removable Devices

5.5.4 BSP 67B Board

Purpose and description

The Beamforming & Signal Processing Board (BSP 67B) is a double cPCI board. The BSP67B Board is used by the Transceiver Unit for beamforming and signal processing purposes. The processing power in the BSP 67B Board is based on sixteen Texas C6713B digital signal processors (DSP) working in parallel.

Figure 23 BSP 67B Board

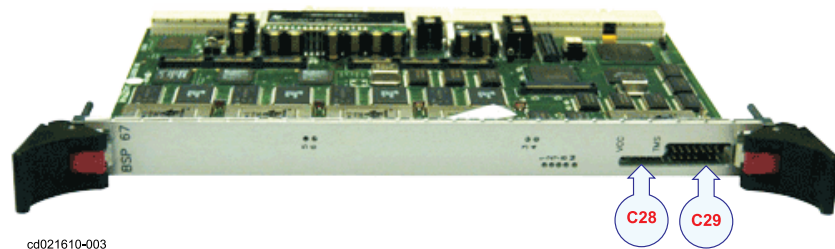

cd021610-003

Specifications

Power consumption: 40W at 3.3 Vdc / 5Vdc

Facilities

LEDs

There is one LED for each of the sixteen DSPs. The LEDs are marked M4, 5, 6, 7, M0, 1, 2, 3 on both Base board and Mezzanine Board. The upper row is for Mezzanine Board. When BSP 67B is loaded, the LEDs will normally flash with a frequency at 1 Hz. LEDs marked B and P are for test purpose only.

External connections

The following cables can be connected to the circuit board

- **C28 - VCC to TMS** For FPGA programming and test purpose

This cable is connected to the VCC slot to provide a JTAG interface to the FGPA modules on the BSP 67B board. The signals of the VCC slot are available at a 36-pin single line header.

Note

This interface is only to be used by Kongsberg Maritime personnel.

- **C29 - TMS** For test purposes only

This cable is connected to the TMS Emulator slot for programming and development purposes. The signals of the TMS slot are available at a 14-pin double line header.

Note _____

This interface is only to be used by Kongsberg Maritime personnel.

5.5.5 Ethernet Switch Board – Gigabit

Purpose and description

This is a 12 channel cPCI Ethernet Switch Board. It is used to interconnect the RX32 Receiver Boards and TX36 Transmitter Boards with the CPU Board.

Figure 24 Ethernet Switch Board

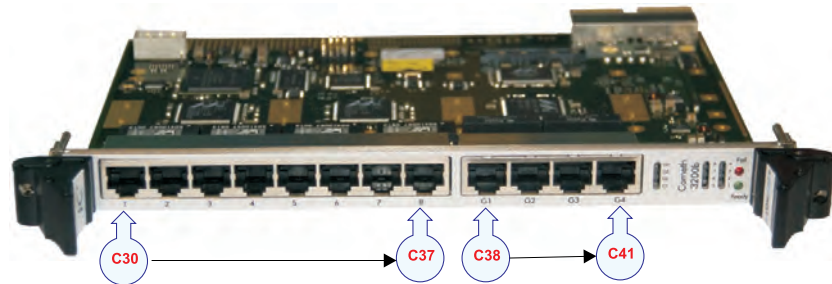

CD021098-006

Key features

- 8 ports of fast and 4 Giga Ethernet ports, auto-negotiating, front panel
- Full wire speed layer 2/3 switching on all ports
- Auto address learning
- Auto address aging

Specifications

- Power consumption: 3.3 Vdc or 5 Vdc Power supply up to 18 Watts according to the configuration
- 1 – 8 Ethernet ports: 10/100TX
- G1 – G4 Ethernet ports: 10/100/1000BT
- Port routing: RJ-45 10/100/1000 BaseTX (at front)

Facilities

Front panel LEDs

- Power supply and CPU Status
- Switched ports : activity/link

External connections: The following cables can be connected to the circuit board

- **C30 to C37 – 100 Megabit Ethernet ports**

The Ethernet cables are equipped with standard RJ-45 connectors. The Ethernet board has 12 Ethernet ports. 8 fast ports * 10/100TX (FB) and 4 giga ports * 10/100/1000BT (FB)

The Ethernet interface of each RX32 receiver board and some of the TX36 transmitter boards are connected to fast ports from C30 to C37.

C31 to C34 – Here must RX32 be connected.

One Ethernet port must be used to communicate with the CPU board.

These cables are provided by the manufacturer. Each cable is cut to a suitable length for connection to dedicated ports. The cable ends are labelled accordingly.

For cable details see *Ethernet cable with RJ45* on page 131.

- **C38 to C41 – Giga ports**

The output data to the Raw data logger must be connected to port number C40.

C41 connects to next switch board.

These cables are provided by the manufacturer. Each cable is cut to a suitable length for connection to dedicated ports. The cable ends are labelled accordingly.

For cable details see *Ethernet cable with RJ45* on page 131.

Connection for Gigabit card – 0.5x1, 1x1, 1x2 and 2x2 degree system

- **C30** – 1 connected to CPU/LAN label ETH1–1
- **C31** – 2 connected to RX32 – 1 / label ETH1–2
- **C32** – 3 connected to RX32 – 2 / label ETH1–3
- **C33** – 4 connected to RX32 – 3 / label ETH1–4
- Not used on 1x2 and 2x2 degree system
- **C34** – 5 connected to RX32 – 4 / label ETH1–5
- Not used on 1x2 and 2x2 degree system
- **C35** – 6 connected to TX36 – 1 / label ETH1–6
- **C36** – 7 connected to TX36 – 2 / label ETH1–7
- **C37** – 8 connected to TX36 – 3 / label ETH1–8
- **C38** – G1 connected to TX36 – 4 / label ETH1–G1
- **C39** – G2 connected to TX36 – 5 / label ETH1–G2
- **C40** – G3 connected to RDL / label ETH1–G3
- **C41** – G4 connected to ETH2–10 / label ETH1–G4

5.5.6 Ethernet Switch Board – Megabit

Purpose and description

This is a 12 channel cPCI Ethernet Switch Board. It is used to interconnect the RX32 Receiver Boards and TX36 Transmitter Boards with the CPU Board.

Figure 25 Ethernet Switch Board with arrows

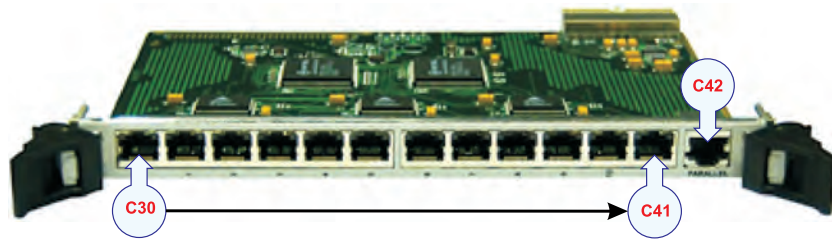

Key features

- 12 ports of 10/100BaseTX, auto-negotiating, front panel
- Full wire speed layer 2 switching on all ports
- 1k MAC address table
- Auto address learning
- Auto address aging

Specifications

Power consumption: 1.2 A at 3.3 Vdc

Ports: 10/100 BaseTX: 12

Parallel port: 1

Port routing: RJ-45 10/100 BaseTX (at front)

Facilities

LEDs: None

External connections: The following cables can be connected to the circuit board

- **C30 to C41 - Ethernet ports**

The Ethernet cables are equipped with standard RJ-45 connectors. The Ethernet board has 12 Ethernet ports (0 to 11). The Ethernet interface on the TX36 transmitter boards must be connected to an Ethernet board.

These cables are provided by the manufacturer. Each cable is cut to a suitable length for connection to dedicated ports. The cable ends are labelled accordingly.

- **C42 - Parallel port – not used**

The parallel port has a standard Ethernet RJ-45 interface. This interface is not used.

Connection for Megabit card no 2 – 0.5x1, 1x1 and 1x2 degree system

- **C30** – 0 connected to TX36 – 6 / label ETH2–0
- **C31** – 1 connected to TX36 – 7 / label ETH2–1
- **C32** – 2 connected to TX36 – 8 / label ETH2–2
- **C33** – 3 connected to TX36 – 9 / label ETH2–3
- **C34** – 4 connected to TX36 – 10 / label ETH2–4
- **C35** – 5 connected to TX36 – 11 / label ETH2–5
- **C36** – 6 connected to TX36 – 12 / label ETH2–6
- **C37** – 7 connected to TX36 – 13 / label ETH2–7
- **C38** – 8 connected to TX36 – 14 / label ETH2–8
- **C39** – 9 connected to TX36 – 15 / label ETH2–9
- **C40** – 10 connected to ETH1–G4 / label ETH2–10
- **C41** – 11 connected to ETH3–10 / label ETH2–11
- **C42** – not in use

Connection for Megabit card no 3 – 0.5x1, 1x1 and 1x2degree system

- **C30** – 0 connected to TX36 – 16 / label ETH3–0
- **C31** – 1 connected to TX36 – 17 / label ETH3–1
- **C32** – 2 connected to TX36 – 18 / label ETH3–2
- **C33** – 3 connected to TX36 – 19 / label ETH3–3
- **C34** – 4 connected to TX36 – 20 / label ETH3–4
- **C35** – 5 Not used
- **C36** – 6 Not used
- **C37** – 7 Not used
- **C38** – 8 Not used
- **C39** – 9 Not used
- **C40** – 10 connected to ETH2–11 / label ETH3–10
- **C41** – not in use
- **C42** – not in use

5.5.7 Power Supply PSU 6V

Purpose and description

This is a 6 V / 25 A power supply. It is used to supply DC power to the analog part of the RX32 Receiver Boards.

Figure 26 Power Supply PSU 6V



Specifications

Input:

- Maximum operating range: 90 to 264 Vac
- Nominal input voltage range: 110 to 240 Vac, 47 to 64 Hz
- Inrush current: < 10 A in 10 ms
- Power factor: > 90 %

Output:

- Output voltage: 6 Vdc \pm 2 %
- Switching frequency: 166.667 kHz
- Output current limit: < 28 A
- Minimum load: 1 A
- Maximum load: 25 A continuously
- Line regulation: < \pm 0.2 %
- Load regulation: < \pm 1 %
- Ripple and noise: < 60 mV (peak-to-peak)

Facilities

LEDs:

- Green: Power good

External connections:

- None

5.5.8 RX32 receiver board

The RX32 Receiver Board is designed for reception and processing of transducer data.

Figure 27 RX32 Receiver Board



Note

Circuit boards are delicate items. They may work year after year in an advanced product, but then fail due to a small spark of static electricity. For this reason, it is very important that they are properly handled and protected during handling.

- Power supplies
- Network FPGA and surrounding components
- Receiver part, 32 identical FPA receiver channels

The RX32 Receiver Board includes 32 independent FPA (Floating Point Amplifier) receivers. The operating frequency is programmable within the range 10 to 500 kHz. All command input and sample data output are communicated via a 100 Mbit/s Ethernet interface.

The receivers generate band pass filtered complex sample data at a programmable output rate. The sample values from all 32 receivers can be output via the Ethernet interface without further processing. Onboard power circuitry generates all internal voltage from a +12 Vdc and a +6 Vdc input.

The receiver is based upon the FPA ASIC (Application-Specific Integrated Circuit). The FPA ASIC is a complete one-channel frontend, including all the signal-processing from the transducer input to a digital serial interface to a signal processor. The RX data is collected by a FPGA (Field Programmable Gate Array).

A 4 bit nibble link in the backplane is used to transfer the sample values from the RX32 board to the BSP 67B board(s).

Figure 28 RX32 simplified block diagram

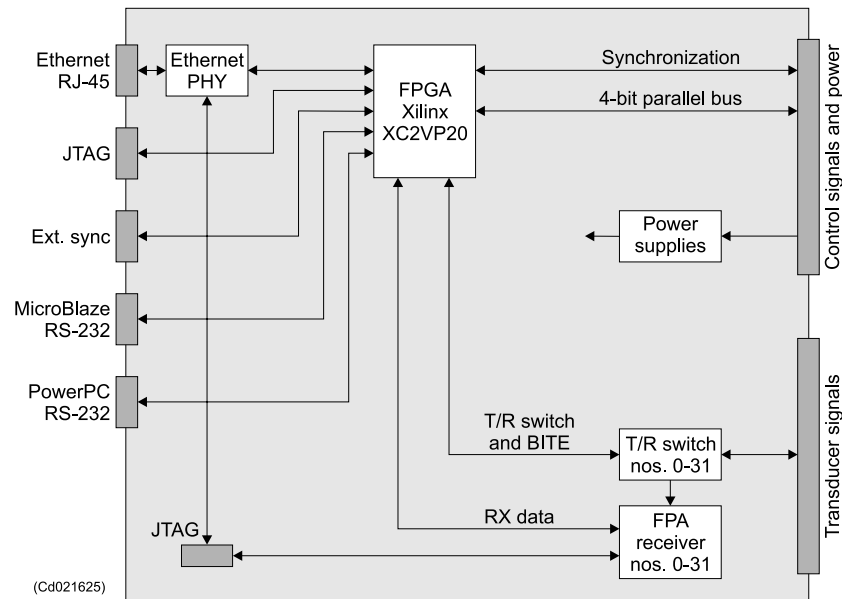

Technical specifications

These are the main technical specifications for the RX32 Receiver circuit board. Please note that technical specifications can be altered without prior warning.

Power supply specifications

- Main supply voltages: +6 V, +12 V
- Current consumption: 2.5 A (6 V), 0.75 A (12 V)

Transducer interface

- Number of channels: 32
- Receiver input impedance: 75 ohms or 1000 ohms, software selectable
- Transducer connections: Differential
- Transducer connector: 96-pin Euro connector

Interface specifications

- Ethernet: 10/100Mb/s
- Nibble Bus: Special 4-bit interface
- ID0 to ID4: Active high identification bits 0 to 4 (maximum 32 board addresses)
- ID5 to ID7: Active high identification bits 5 to 7 (maximum 8 rack addresses)
- CLK20MHZ: Differential system master clock, 20 MHz
- RESET: Differential active low reset, synchronized to negative edge of CLK20MHZ

- MASTER: Active low, enables master signal source
- PS_SYNC: Switching power supply synchronization

Receiver specifications

- Input termination: Fully differential input
- Input impedance: Matched to transducer (75 ohms) or high impedance (1 kohm)
- Frequency range: 10 to 500 kHz
- Low pass filter: Anti-aliasing, 62.5, 125, 250 and 500 kHz
- Gain: 0 to 90 dB in 6 dB steps
- Noise figure:
 - Impedance matching: 5 dB
 - High impedance: 2 dB
- Sampling: Simultaneous sampling of all channels, 2 MHz
- Automatic Gain Selection (AGS): Implemented for each channel, selects optimum gain setting to make best use of analogue to digital input range
- Analogue to digital conversion: 12 bit resolution
- Dynamic range: > 140 dB
- Signal processing: Digital demodulation, filtering and decimation (ratio 7 – 256)

The receiver technology is based on the **Floating Point Amplifier (FPA)** ASIC. Eight of these ASICs in die form are used on the eight channel **FPA8** hybrid circuit. This hybrid circuit also includes necessary surrounding components, such as power supply decoupling.

Facilities

LEDs

- Ethernet: Four LEDs display Ethernet operating mode and activity
- LINK: The connection to the external device is OK (green)
- SPEED: The detected bit rate is 100 Mbit/s (yellow)
- ACTIVITY: Flashing light indicates transmit and receive activity (green)
- DUPLEX: The interface operates in full duplex mode (yellow)

I/O

- I/O: Eight yellow LEDs display processor activity and error conditions.

- IO 0: The PowerPC embedded program broadcasts a BOOTP/DHCP (Boot Strap Protocol / Dynamic Host Configuration Protocol) request via the Ethernet interface.
- IO 1: A BOOTP/DHCP reply message has been received from an external boot server.
- IO 2: The PowerPC sends a TFTP (Trivial File Transfer Protocol) request to the boot server asking for its application program.
- IO 3: The PowerPC embedded program is up and running. The PowerPC embedded program is included in the FPGA firmware as initialized block RAM.
- IO 4: This LED flashes when the receivers are running and generating sample data. The flash speed is proportional to the receiver decimation clock.
- IO 5: This LED is reserved for product maintenance tasks.
- IO 6: This LED flashes every time TXENABLE goes active.
- IO 7: The MicroBlaze embedded program is up and running. The MicroBlaze embedded program is included in the FPGA firmware as initialized block RAM.

Power

- Power: Five green LEDs indicate that the internal supply voltages are OK.
- +5 V
- +2.5 V
- +3.3 V
- +6 V
- +12 V

Figure 29 RX32 Receiver Board with arrows

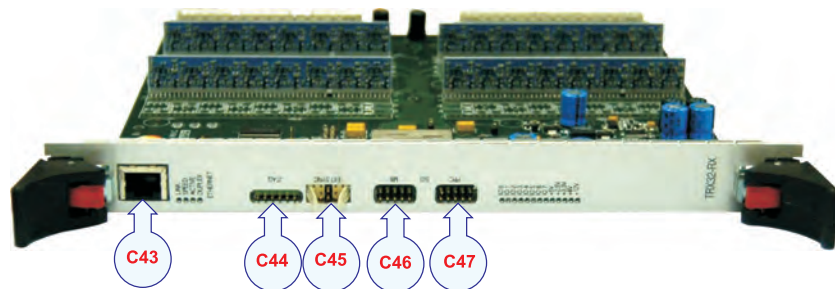

External connections**• C43 - Connected to Ethernet switch board**

The Ethernet cable is equipped with a standard RJ-45 connector. The Ethernet interface of the RX32 receiver board must be connected to an Ethernet switch board. This interface is used for all command input and sample data output. This is normally the only cable connected to the RX32 receiver board. It is provided by the manufacturer. *Ethernet cable with RJ45* on page 131.

• C44 - JTAG / For internal use only

This cable is connected to the JTAG slot to provide a JTAG interface to the FGPA modules on the RX32 receiver board. The signals of the JTAG slot are available at a 6-pin single line header.

Note _____

This interface is only to be used by Kongsberg Maritime personnel.

• C45 - External synchronization (EXT SYNC) / For internal use only

This cable is connected to the EXT SYNC slot for accurate transmit synchronization with external equipment. The signals of the EXT SYNC slot are available at a 10-pin double line header.

Note _____

This interface is only to be used by Kongsberg Maritime personnel.

• C46 - MicroBlaze (MB) / For internal use only

This cable is connected to the MB slot for debugging the MicroBlaze (FPGA soft-core processor) program software. The signals of the MB slot are available at a 10-pin double line header.

Note _____

This interface is only to be used by Kongsberg Maritime personnel.

- **C47 - PowerPC (PPC) / For internal use only**

This cable is connected to the PPC slot for debugging the PowerPC (FPGA hard-core processor) program software. The signals of the PPC slot are available at a 10-pin double line header.

Note _____

This interface is only to be used by Kongsberg Maritime personnel.

5.5.9 RX RIO – Rear Interface Board

Purpose and description

This is the rear I/O module for the RX32 Receiver Board. It holds transformers and band pass filters. It also connects the 32 receiver channels to the 78-pin connector. The signals are low level ac signals, $< 5\text{ V}$ and $< 0.1\text{ A}$.

Figure 30 RX RIO

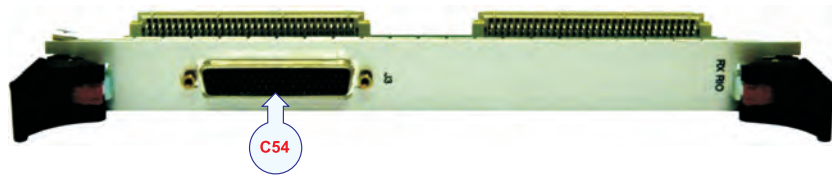

Facilities

LEDs

- None

External connections

- C54 - RX transducer

5.5.10 RXP RIO – Rear Interface Board

Purpose and description

This is a rear I/O module with AC input filter. It connects the 115/230 Vac input to the backplane. One AC output plug with filter is also available for the possibility to connect an extra fan module (not used).

Figure 31 RXP RIO

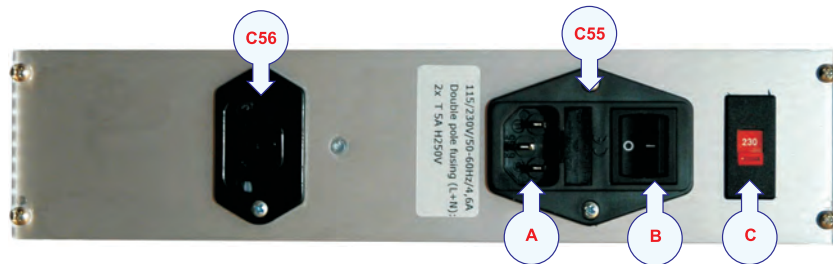

Facilities

LEDs

- None

External connections

- **C55 – AC power**
 - A AC power
 - B Power On/off, normally set to on
 - C Switch – 115/230 V for the fan unit

This is a 115/230 Vac AC mains cable. Cable C55 is equipped with a 3-pin IEC female socket.

C55 connects to the TXP RIO board and the cable are provided by the manufacturer.

For cable details, see *Standard AC power cable* on page 130

- **C56 – AC power**
normally not used

5.5.11 BSP RIO – Rear Interface Board

Purpose and description

This is the rear I/O module for the master BSP. It holds control signals from the TX sub-rack (power sync), external trig interface (TX pulse output, RX ready output, trig input) and 1PPS input.

Figure 32 BSP RIO



Facilities

LEDs:

- None

External connections

- **C57 - 1PPS**

This is a standard coaxial cable. It is used to provide a 1PPS timing signal.

External synchronisation and remote on/off on page 38

Generic coax cable on page 124

- **C58 - Trigger in/out**

This cable is equipped with a standard 9-pin D-sub connector.

The interface is used to synchronize the echo sounder's transmissions with other acoustic instruments.

This interface is normally not used (see cable C71).

Trigger in/out (not used) on page 127

- **C59 - Control signals**

This cable is equipped with a standard 15-pin D-sub connector and is connected to the TXP RIO board.

The interface is used to transmit internal synchronization signals and TX enable signals (time stamp of TX pulses).

This cable is provided by the manufacturer.

Internal control signals on page 128

5.5.12 Rear I/O Interface Board (Kontron)

Purpose and description

This is the rear I/O module for external sensors. For this purpose, it is equipped with four serial lines and two Gbit ethernet links.

Figure 33 I/O Interface Board

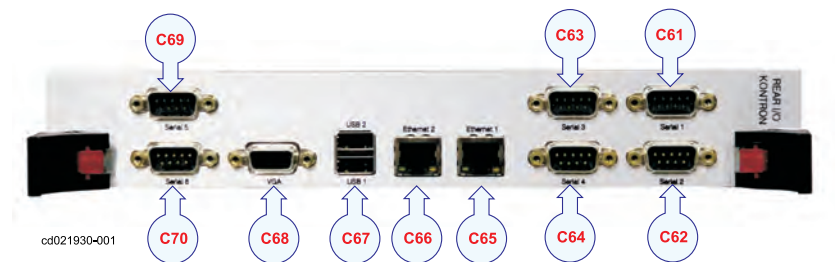

Facilities

LEDs:

None

External connections

- **C61 / C64 - Serial lines 1 - 4, 9 pin D-sub, RS232**

These cables are equipped with 9-pin connectors. These interfaces are used for connection to external sensors (position, attitude etc.).

The serial lines are normally set up as follows

- **Serial Port 1** - Positioning systems
- **Serial Port 2** - Motion sensor
- **Serial Port 3** - Auxiliary 1
- **Serial Port 4** - Auxiliary 2
- **C65 / C66 - Ethernet, RJ45**
 - **C65** – **Ethernet 1** to operator station.
 - **C66** – **Ethernet 2** is a velocity input from motion sensor. This input is needed for doppler compensation in FM mode.
- **C67 - USB**

The USB cable is equipped with a standard USB2 connector and it is only used for system testing by Kongsberg Maritime personnel.
- **C68 - VGA**

This cable is equipped with a standard 15-pin D-sub connector. This interface is only used for system testing by Kongsberg Maritime personnel.

- **C69 / C70 - Serial lines 5 and 6**, not used.

These cables are equipped with standard 9-pin D-sub connectors.

5.5.13 Raw data logger interface (RDL)

Purpose and description

This is a Gigabit Ethernet output for a raw data logger option. This “unit” is connected internally to the TRU GBit switch board.

The RDL is a real time software application that provides the capability to log raw hydrophone data from hydrographic instruments produced by Kongsberg Maritime.

The communication between the RDL and the transceiver unit uses a 1 Gbit Ethernet line.

Figure 34 RDL board



Facilities

LEDs:

- None

External connections

- **C85 - Ethernet**

Ethernet cable to an optional Raw data logger.

Ethernet cable with RJ45 on page 131

5.5.14 TX36 transmitter board

The TX36 Transmitter Board is designed for processing and transmission of transducer data.

Note

Circuit boards are delicate items. They may work year after year in an advanced product, but then fail due to a small spark of static electricity. For this reason, it is very important that they are properly handled and protected during handling.

Figure 35 TX36 Receiver Board



- Power supplies
- Network FPGA
- TX FPGA
- Transmitter part, 36 identical PWM transmitter channels

The TX36 Transmitter Board includes 36 independent PWM (Pulse Width Modulation) transmitters. The operating frequency is programmable within the range 10 to 500 kHz. All command input and sample data output are communicated via a 100 Mbit/s Ethernet interface.

The board includes software for synthesizing the transmit signal at runtime. A variety of different beam shapes and time signals can be generated by entering a few high level input parameters. Onboard power circuitry generates all internal voltages from a +12 Vdc input. A separate high voltage input is provided for feeding the output stage of the transmitters.

The transmitters are based on a PWM (Pulse Width Modulation) technique, with a switching frequency of 2 MHz. This makes it possible to generate arbitrary signals in the whole frequency band 10 to 500 kHz. Traditional CW pulses at any frequency or amplitude can be generated, as well as more complex waveforms, and several simultaneous signals. These signals are specified by the user and generated in the TX FPGA.

Figure 36 TX36 simplified block diagram

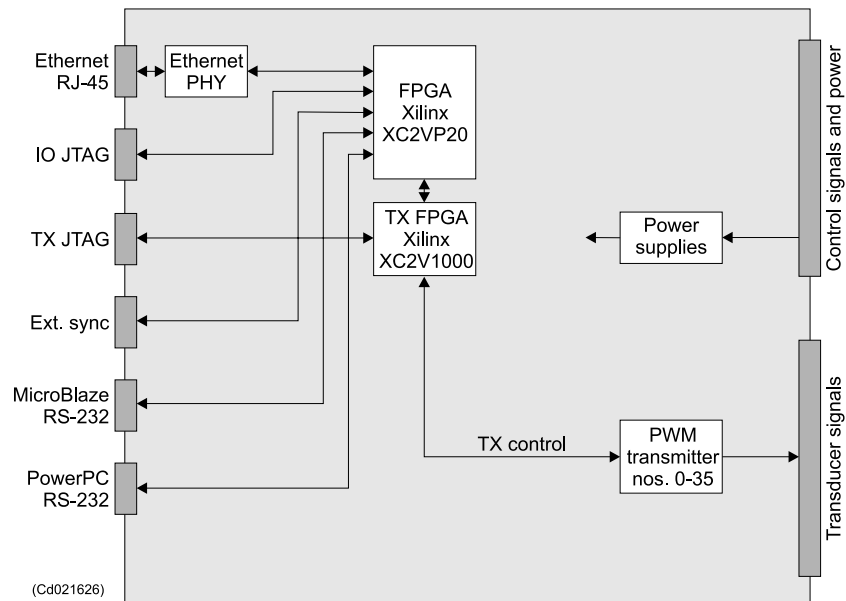

Technical specifications

These are the main technical specifications for the TX36 Receiver circuit board. Please note that technical specifications can be altered without prior warning.

Mechanical characteristics

- Type: Double “eurocard”, extended board format
- Length: 220 mm
- Height: 233.4 mm
- Width: 25.4 mm (5U)
- Weight: Approximately 950 grams

Power supply specifications

- Main supply voltages: +12 Vdc (used for the TX driver circuits) and HV (high voltage supply for the transmitter output stage)
- Maximum mean current consumption: <1 A (12V)
- Internal current consumption: 2.0 A (5 Vdc), 0.6 A (3.3 Vdc), 1.2 A (1.8 Vdc)

These are the external power supply requirements, excluding current from 12 V supply for transmission drivers (approximately 0.1 A per channel during the transmission pulse).

Transducer interface

- Number of channels: 36

- Transducer impedance: 75 ohm
- Transducer connections: Single-ended
- Transducer connector: 96-pin Euro connector

Interface specifications

- Ethernet: 10/100Mb/s
- ID0 - 4: Active high Identification Bit 0-4 (maximum 32 board address)
- CLK20MHZ: Master clock in system, 20 MHz
- RESET~: Active low, synchronized to negative edge of CLK20MHZ
- TXENABLE~: Active low, synchronized to negative edge of CLK20MHZ
- MASTER~: Active low, enables master signal source

Transmitter

- Output signal frequency range: 10 to 500 kHz
- PWM switching frequency: 20 MHz
- Output signal waveform: Arbitrary waveform, described by “Nyquist samples”
- Max. output power: 50 W
- Max. pulse length: 400 ms
- Max. duty cycle: 10 % (frequency dependant)
- High voltage supply: 0 to 170 Vdc.

Facilities

LEDs

- LINK: The connection to the external device is OK (green)
- SPEED: The detected bit rate is 100 Mbit/s (yellow)
- ACTIVITY: Flashing light indicates transmit and receive activity (green)
- DUPLEX: The interface operates in full duplex mode (yellow)
Ethernet: Four LEDs display Ethernet operating mode and activity
- TX: Eight yellow LEDs display transmission activity.

I/O

- IO 0: The PowerPC embedded program broadcasts a BOOTP/DHCP (Boot Strap Protocol / Dynamic Host Configuration Protocol) request via the Ethernet interface.
- IO 1: A BOOTP/DHCP reply message has been received from an external boot server.

- IO 2: The PowerPC sends a TFTP (Trivial File Transfer Protocol) request to the boot server asking for its application program.
- IO 3: The PowerPC embedded program is up and running. The PowerPC embedded program is included in the FPGA firmware as initialized block RAM.
- IO 4: This LED flashes when the receivers are running and generating sample data. The flash speed is proportional to the receiver decimation clock.
- IO 5: This LED is reserved for product maintenance tasks.
- IO 6: This LED flashes every time TXENABLE goes active.
- IO 7: The MicroBlaze embedded program is up and running. The MicroBlaze embedded program is included in the FPGA firmware as initialized block RAM.

I/O: Eight yellow LEDs display processor activity and error conditions.

Power

- Power: Five green LEDs indicate that the internal supply voltages are OK.
- +5 V
- +2.5 V
- +3.3 V
- +6 V
- +12 V

Figure 37 TX36

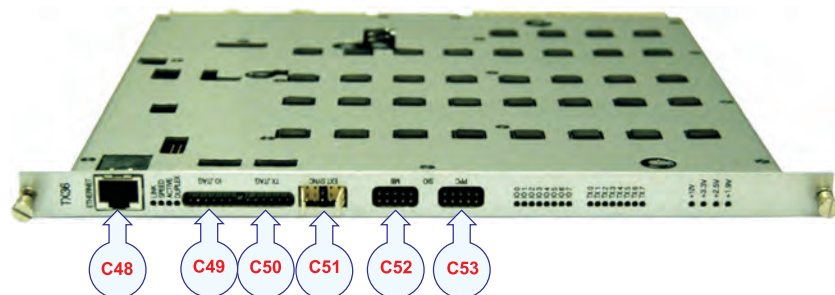

External connections**• C48 - Connected to Ethernet switch board**

The Ethernet cable is equipped with a standard RJ-45 connector. The Ethernet interface of the TX36 transmitter board must be connected to an Ethernet switch board. This interface is used for all command input and sample data output. This is normally the only cable connected to the TX36 transmitter board. It is provided by the manufacturer.

For cable details see *Ethernet cable with RJ45* on page 131.

• C49 - IO JTAG / For internal use only

This cable is connected to the IO JTAG slot to provide a JTAG interface to the FPGA modules on the TX36 transmitter board. The signals of the IO JTAG slot are available at a 6-pin single line header.

Note _____

This interface is only to be used by Kongsberg Maritime personnel.

• C50 - TX JTAG / For internal use only

This cable is connected to the TX JTAG slot to provide a JTAG interface to the FPGA modules on the TX36 transmitter board. The signals of the TX JTAG slot are available at a 6-pin single line header.

Note _____

This interface is only to be used by Kongsberg Maritime personnel.

• C51 - External synchronization / For internal use only

This cable is connected to the EXT SYNC slot for accurate transmit synchronization with external equipment. The signals of the EXT SYNC slot are available at a 10-pin double line header.

Note _____

This interface is only to be used by Kongsberg Maritime personnel.

- **C52 - MicroBlaze (MB) / For internal use only**

This cable is connected to the MB slot for debugging the MicroBlaze (FPGA soft-core processor) program software. The signals of the MB slot are available at a 10-pin double line header.

Note _____

This interface is only to be used by Kongsberg Maritime personnel.

- **C53 - PowerPC (PPC) / For internal use only**

This cable is connected to the PPC slot for debugging the PowerPC (FPGA hard-core processor) program software. The signals of the PPC slot are available at a 10-pin double line header.

Note _____

This interface is only to be used by Kongsberg Maritime personnel.

5.5.15 Power Supply PSU 12V

Purpose and description

This is a 12 V / 24 A power supply. It is used to supply DC power to the TX36 Transmitter Boards. It can also deliver 72 A extra during transmit (with maximum 10 % TX duty cycle).

Figure 38 Power Supply PSU 12V



Specifications

Input:

- Maximum operating range: 90 to 264 Vac
- Nominal input voltage range: 110 to 240 Vac, 47 to 64 Hz
- Inrush current: < 10 A in 10 ms
- Power factor: > 90 %

Output:

- Output voltage: 12 Vdc \pm 2 %
- Switching frequency: 166.667 kHz
- Output current limit: < 27 A, approx. 500 ms delay
- Minimum load: 1 A
- Maximum load: 24 A continuously (dependent on number of TX36 boards)
- Maximum load: 100 A, < 400 ms
- Line regulation: < \pm 0.2 %
- Load regulation: < \pm 1 %
- Ripple and noise: < 100 mV (peak-to-peak)

Facilities

LEDs:

- Green: Power good

External connections

- None

5.5.16 TXP RIO – Rear Interface Board

Purpose and description

This is a rear I/O module with the following features

- AC input with filter and fuse
- AC output for RX sub-rack
- Buffer for LVDS control signal
- Bleeder for TX power
- Remote on/off and synchronisation interface
- Relay for remote control
- Heater element

The heater element is turned on when the TRU is turned off.

- Fuses
- 115 / 230 Voltage switch

Figure 39 TXP RIO

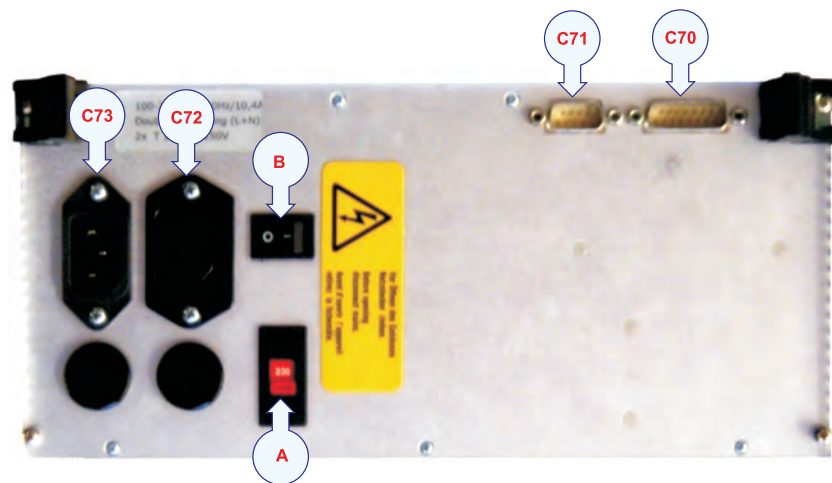

Facilities

LEDs

- None

Power switch

- A - AC power switch for the fan unit
- B - On/off switch – set to off if remote on/off control is used

WARNING

Set to off if remote control is used

External connections

- **C70 - Control signals**

This cable is equipped with a standard 15-pin D-sub connector and is connected to the BSP RIO board.

The interface is used for synchronization signals and TX enable signals (time stamp of TX pulses).

This cable is provided by the manufacturer.

Internal control signals on page 128

- **C71 - Remote On/Off control and synchronization**

This cable is equipped with a standard 9-pin D-sub connector.

The interface is used to connect to a remote On/Off power switch. It is also used for external trigger output and synchronization. For more information, see *External synchronisation and remote on/off* on page 38

Remote control and external trig on page 129

- **C72 / C73 - AC power**

These are 115/230 Vac AC mains cables. Cable C72 must be equipped with a 3-pin IEC male socket and C73 in a female equivalent.

C72 connects AC power to the RXP RIO board. C73 is connected to the ship's mains power.

The cable C72 is provided by the manufacturer.

Standard AC power cable on page 130

5.5.17 TX RIO – Rear Interface Board

Purpose and description

This is the rear I/O module for two TX36 Transmitter Boards. It contains a capacitor bank connected to the HV Power Supply. It also connects the 72 transmitter channels to two 78-pin D-sub connectors. The transmitters have common ground.

These are TX transducer cables terminated in 78-pin D-sub connectors.

Figure 40 TX RIO



Facilities

LEDs:

- None

External connections

- C74 / C75 - TX transducer

These are TX transducer cables terminated in 78-pin D-sub connectors. Each TX RIO board connects to two TX transducer cables.

5.5.18 Power Supply PSU 72V

Purpose and description

This is a 72 V / 5 A power supply. It is used to charge the capacitor battery located on the TX RIO boards.

Figure 41



Specifications

Input

- Maximum operating range: 90 to 264 Vac
- Nominal input voltage range: 110 to 240 Vac, 47 to 64 Hz
- Inrush current: < 10 A in 10 ms
- Power factor: > 90 %

Output

- Output voltage: 72 Vdc \pm 0.5V
- Switching frequency: 167.667 kHz
- Output current limit: < 5.5 A
- Maximum load: 3.5 A continuously
- Maximum load: 5.0 A, < 400 ms
- Line regulation: < \pm 0.2 %
- Load regulation: N/A
- Ripple and noise: < 400 mV (peak-to-peak)

Facilities

LEDs:

- Green: Power good

External connections

- None.

6 TROUBLESHOOTING

6.1 Messages

Introduction

The EM 710 provides numerous messages to inform you of major and minor hardware and software errors.

The messages, if they occur, will be displayed in SIS' Message service window and/or in the Status bar.

The different utilities operating on the EM 710 Operator Station each issue several messages. These messages can be sorted in three categories:

- Information
- Warnings
- Errors

The messages presented as warnings merely point out small inaccuracies, and must be regarded as guidelines to the normal operation of the system.

The operational errors reflect major and minor hardware and software errors, some of which must be acted upon to ensure the normal operational capability.

→ **Refer to the Seafloor Information System (SIS) Operator manual for further information.**

6.2 BIST tests

BSP - Beamformer and Signal Processing

This test checks all Beamformer and Signal Processing circuit boards in the EM 710 Transceiver Unit.

TX36 - Transmitter board

This test checks all TX36 transmitter circuit boards in the EM 710 Transceiver Unit (voltage, current and temperature).

RX32 - Receiver board

This test checks all RX32 receiver circuit boards in the EM 710 Transceiver Unit (voltage, current and temperature).

TRU Power - Transceiver unit

This test checks the 6 V, 12 V and 72 V power supplies in the EM 710 Transceiver Unit. The power level are tested on all RX and TX boards.

RX 32 / BSP link

This test checks the nibble bus interface between the RX 32 receiver circuit boards and the BSP circuit boards. A large set of known data is transferred from each of the RX 32 receiver boards to the BSP boards. The data received by the BSP is verified.

RX channels

This test checks all RX channels (including the transducers). The BIST report lists phase and amplitude response of all RX channels, and also the impedance of the transducers.

TX channels

This test checks all TX channels (including the transducers). This is done by transmitting at one by one TX amplifier. The output voltage and current is measured. This data is used to calculate the transducer element impedance. BIST report lists channels outside the limits.

RX noise level (broadband)

This test measures the average isotropic spectral noise level for each receiver channel (in dB rel 1 $\mu\text{Pa}/\text{Hz}$). Wide RX bandwidth (70 to 100 kHz) is used.

The receiver directivity index, the transducer sensitivity and the bandwidth is used to convert to isotropic spectral noise level.

RX noise spectrum

This test measures the average isotropic spectral noise level for each board (in dB rel 1 $\mu\text{Pa}/\text{Hz}$). It is displayed with 700 Hz steps from 70 to 100 kHz.

TRU software date / version

This test presents the software date and versions for the CPU, BSP, RX32 and TX36 circuit boards.

CPU

This test presents the CPU type, the CPU clock frequency, the current and maximum temperatures for the CPU die and for the CPU board. In addition some key voltages are reported, and finally the network addresses for the board's interfaces.

7 REPLACEMENT PROCEDURES

Topics

- *Procedures for Transceiver Unit* on page 88
- *Power Supply* on page 89
- *Fuse replacement* on page 90
- *Fan drawers* on page 90
- *New BSP RIO card and Jumper Link* on page 91

Safety precautions

The system operates on 115 and/or 230 Vac, 50/60 Hz.

WARNING

This voltage can be lethal.

System power must be switched off before any replacement is carried out. Failure to do so may lead to personal injury, and/or serious damage to the system.

ESD precautions

The replacement procedures presented in this chapter allows you to replace circuit boards. These are delicate devices, and special attention must be made to the handling of these.

The following precautions are therefore very important:

- The working area must be covered by an approved conductive service mat that has a resistance of between 50 k Ω and 2 M Ω , and is connected directly to a reliable ground point via its grounding cord.
- The maintenance technician or engineer must use a grounding bracelet, firmly connected to an ESD grounding point.
 - The bracket in the upper left corner of the EMU serves as ESD grounding point when working in front of the cabinet.
 - The two profile beams mounted on each side wall of the cabinet serves as ESD grounding points when working at the back of the cabinet.
- All circuit boards must be stored in anti-static bags while not in use.

A standard tool set is required to perform the removal and replacement of the modules. This tool set should contain the following tools:

Overview

This chapter presents the basic procedures for disassembly and reassembly of the replaceable parts in the EM 710 system.

A standard tool set is required to perform the removal and replacement of the modules. This tool set should contain the following tools:

Tools required

- Cabinet key
- Standard screwdrivers in different widths and lengths
- Standard cross-slot screwdrivers in different widths and lengths
- Allen keys in metric sizes
- Philips screwdrivers in different sizes
- Pozidrive screwdrivers in different sizes
- Flat nosed pliers
- Lap jointed pliers
- Wire cutters
- Adjustable spanners
- Socket set
- Wire straps in different sizes

7.1 Procedures for Transceiver Unit

The replaceable units in the EM 710 Transceiver Unit are:

Processing and receiver rack

- cPCI Power Supply
- CPU Board
- BSP 67B Boards
- Ethernet Switch Boards
- Power Supply PSU 6V
- RX32 Receiver Boards
- RX RIO Rear Interface Boards
- RXP RIO Rear interface Module
- BSP RIO Rear Interface Board
- Rear I/O Interface Board
- Raw Data Logger (RDL)
- Fuses
- Fan drawers (2 pcs)

Transmitter rack

- Power Supply PSU 12V
- TX36 Transmitter Boards

- TX RIO Rear Interface Boards
- TXP RIO Rear Interface Board
- Fuses
- Fan drawer

The replacement procedures for these parts are described in the following disassembly and reassembly procedures.

Circuit boards and power supplies

The Transceiver Unit holds three sub-racks. All the sub-racks hold plug-in circuit boards.

The replacement of these modules is described in this procedure.

The system must be switched off prior to disassembly. Access is gained to the sub-racks by opening the front door of the Transceiver Unit with a special tool for the cabinet doors. Before removing any modules, be sure that the led in the HV Power supply has no green light on.

Disassembly procedure

- Remove the front mounted cables from the applicable circuit boards
- Release the thumb-screws and other screws if required
- Pull the board/unit carefully out

Replacement procedure

- 1 Insert new circuit boards and modules in reverse order. Mount the front mounted ethernet cable connectors.
- 2 Check that the circuit boards and modules have been installed in their correct locations! Refer to the applicable pictures and drawings.

7.2 Power Supply

There are two power supplies located in the Processing and Receiver Rack. CPCI Power on the left side and one 6 Volt power supply between the Ethernet cards and RX 32 receiver cards.

In the Transmitter sub-rack there are one 12 Volt power supply on the left side.

Disassembly procedure

- 1 Open the front door of the Transceiver Unit.
- 2 Switch off the circuit breaker on the rear side at the transmitter sub-rack.
- 3 Unbolt the unit. It is mounted with four screws so they cannot fall out.

- 4 Release the screws
- 5 Pull out the unit carefully

Reassembly procedure

- 1 The new power supply is replaced by reversing the above procedure

7.3 Fuse replacement

The Transceiver Unit holds several power supplies. Three of these are equipped with primary fuses marked with F1 and F2.

These fuses are mounted in the front on:

- 6 V Power supply
- 12 V Power supply
- 72 V Power supply

Disassembly procedure

- Release the fuse with a screwdriver

Reassembly procedure

- Replace with the same type of fuse by reversing above procedure

7.4 Fan drawers

There are four fan drawers in the Transceiver Unit. Two fan drawers are located underneath the Processing and Receiver sub-rack, one underneath the Transmitter sub-rack.

Access is gained to the sub-racks by opening the front protective cover of the Transceiver Unit.

WARNING

The system must be switched off prior to disassembly.

How to disassembly fan drawers

- 1 Gain access to the wired rack.
- 2 Twist the right and left screw on the fan drawer a few turns.
- 3 Pull the fan drawer carefully out.

How to reassembly fan drawers

- 1 Reverse the above procedure.

7.5 New BSP RIO card and Jumper Link

Before installing the jumper link, check that system are shout down

This procedure is not for TRU compact 2 x 2 degree system.

Procedure for how to mount a new BSP RIO card with registration number: 316694 in a TRU that has the old BSP RIO card with registration number: 382–219683

How to install the jumper link

- 1 The system has to be turned off – no power
- 2 Remove the RX32 card number 1 and number 2 in the front of the TRU
- 3 Insert the component – see figure *Overview of the installing place of Jumper Link* on page 92

Since the component is very small – it would be useful to use a pliers for holding the component and for installation for the component.

- 4 Insert the RX32 cards
- 5 Change from the old BSP RIO card to the new BSP RIO card
- 6 Power up the system

If the installation of the component is wrong – the system will not work.

Figure 42 Overview of the installing place of Jumper Link

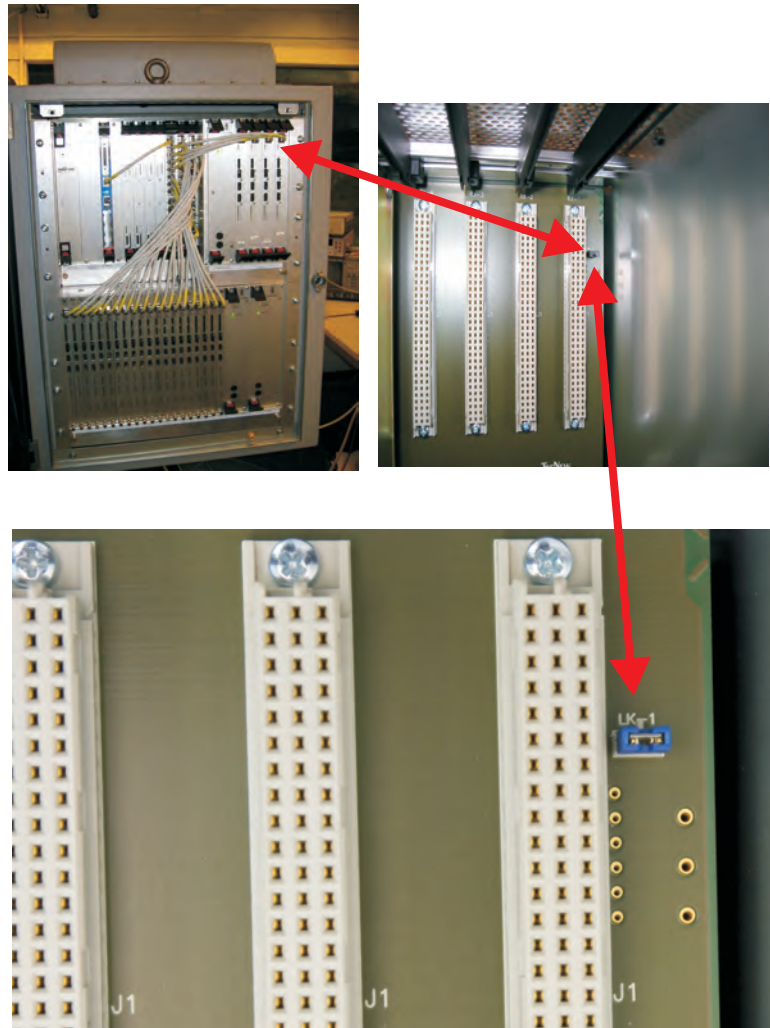

8 SPARE PARTS

This chapter contains an illustrated presentation of the spare parts available for the EM 710 multibeam echo sounder. All parts are minimum of what we recommend onboard and at site.

Table 8 Power Supplies

Pc	TRU ompact 2 x 2degree system	Normal system	Parts
1	382-099656	382-099656	Power Supply cPCI
1	382-098939	382-098939	Power Supply PSU-6 V
1	302991	382-098938	Power Supply PCU-12 V
1	382-098940	382-098940	Power Supply PSU-HV

Table 9 Receiver Unit

Pc	TRU ompact 2 x 2degree system	Normal system	Parts
1	311806	311806	CPU Board Kontron KIT, Following two items:
1	323771	323771	PCB BSP 67B
1	309057	309057	PCB RX 32
1	382-219486	382-219486	Interface card RX RIO
1	302124	302124	CPU Inteface card RIO
1	313255	316694	BSP RIO
1		328545	Gigabit Ethernet Switch
1	719-098950	719-098950	Megabit Ethernet Switch
1		322096	RDL Board

Table 10 Transmitter Unit

Pc	TRU ompact 2 x 2degree system	Normal system	Parts
2	382-206644	382-206644	PCB TX 36
1	382-219483	382-219483	Interface Card TX RIO
1	382-098822	382-098822	RIO TXP

Note

With regard to "PCB TX 36", it is recommended to include

- 3 x PCB's for 0,5 and 1 degree systems
- 2 x PCB's for 2 degree system

With regard to "Interface card TX RIO", it is recommended to include

- 2 x PCB's for 1 degree system
- 1 x PCB for 2 degree system

Table 11 Hydrographic Workstation

Pc	Our part number	Parts
1	324098	HWS
1	301942	Hard disk

9 MAINTENANCE PROGRAM

The purpose of this document is to provide guidance to operators and maintainers on recommended maintenance procedures for multi beam echo sounders and ancillary equipment. The guidelines will assist in keeping the equipment fully operational and in detecting problems and malfunctions as early as possible.

9.1 Before every survey (alongside)

The following systems shall be maintained:

Remove old surveys.

If possible, delete all surveys from the hard disks on the EM Operator stations. This will ensure that different surveys are not mixed together and that all data disks are empty at survey start.

Defragment all survey disks.

At survey start, and during the survey (if time allows), defragment the data disk(s). This is performed to optimise the disk capacity.

Run all BISTS.

The system has several BIST incorporated in the system software. Run all these to verify correct system operation or take corrective action if any alarms appears.

Verify operation of all external sensors.

The various multi beam echo sounders are part of an integrated system with several external sensors. Verify operation of each ancillary system using the relevant technical and operational manuals. Perform corrective actions if necessary.

9.2 Before every survey (offshore)

Roll calibration check

Perform a Roll calibration as described in the operator manual and verify if any roll offset values have changed. If different from the last check, update and verify.

Pitch calibration check

Perform a Pitch calibration as described in the operator manual and verify if any pitch offset values have changed. If different from the last check, update and verify.

Cross line verification check

To check the sound speed corrections, run two lines perpendicular to each other and verify the swath versus the centre beam.

9.3 Every time used

Clean the SVP probe in fresh water.

Each time the SVP unit is used, it shall be cleaned in fresh water and stored in a dry and safe place. Verify that no physical damage is done to the unit and that the sacrificial anodes (if any) are all intact.

9.4 Every 6 months

Check all external cables

All interface cables are connected to the various electronic units by delta connectors or similar. Verify that all connectors are securely fastened and that all cables are free from physical damage.

Clean all air filters

Wherever there are air filters, they shall be cleaned at least every 6 months. If the units are installed in a dirty environment, then shorter intervals between cleaning may be required.

Hoover the inside of every cabinet.

Each cabinet should be cleared of dust and other particles at least every 6 months. A suitable Hoover should be used for this work, ensuring that no metallic parts are used inside the cabinets. System power must be isolated prior to cleaning.

WARNING

UTMOST CARE MUST BE TAKEN DURING THIS OPERATION

9.5 Every dry-docking

Docking

WARNING

For cleaning – do not use high pressure cleaner or simular.

All transducers should be checked when the ship is in dry-dock. Remove very carefully all marine growth with only a **wood** or **plastic** ice scraper. Then renew the anti fouling paint on the transducer faces. Great care must be taken when performing this.

How to do replace the anti fouling paint

- The transducer has to be rubbed softly with hand with a very fine sand paper.

- A thin layer of primer dependent of the frequency of the system
- Antifouling type SeaQuantum Ultra, Layer thickness 125 micron

Primer on 300 kHz and 200 kHz systems: Penguin primer, 75 micron layer thickness.

Primer on all other systems: Safeguard Universal ES, 125 micron layer thickness.

Note _____

The last primer is giving the best protection but contains micro sized aluminium grains and has yet not been tested for 200 and 300 kHz systems.

This is Kongsberg Maritime's list of approved antifouling paints on polyurethane transducer housing.

From Jotun Paints, Sandefjord Norway

- Antifouling Seamate HB 33
- Antifouling Seamate HB 66
- Antifouling Seamate HB 99
- Racing
- Non-stop

From International Paints

- Intersleek tie coat +425 FCS
 - BXA386/BXA390/BXA391 grey
 - HKA563/HKA570/HKA571 Yellow

Mix BXA386, BXA390 and BXA391 first, then apply. When dry, mix HKA563, HKA570 and HKA571, apply.

From Hempel IFA Coatings AS

- Hempel A/F Classic 76550

From Jotun-Henry Clark Ltd

- Anti-fouling Seaguardian

Note _____

refer to the manufacturer's documentation and data sheets for a complete procedure.

Diver

There is also one opportunity for a diver to the gently scrap of the arrays with a **wood** or **plastic** scraper.

10 INSTALLATION DRAWINGS

This chapter contains installation drawings and cable details.

If required, certain drawings may be supplied on AutoCad or PDF format. To order, contact Kongsberg Maritime and refer to the drawing number in the bottom right corner of the frame.

Installation drawings

- *0.5° mounting frame assembly TX module* on page 99
- *1° mounting frame assembly RX module* on page 101
- *2° mounting frame assembly TX/RX module* on page 103
- *0.5 x 1° gondola* on page 105
- *Transducer TX1 Outline dimensions* on page 107
- *Transducer TX2 Outline dimensions* on page 109
- *Transducer RX1 Outline dimensions* on page 111
- *Transducer RX2 Outline dimensions* on page 113
- *HWS Operator Station Outline dimensions* on page 115
- *Transceiver Unit Outline dimensions* on page 116
- *Transceiver Unit 2 x 2 degree system – Outline dimensions* on page 118
- *Transceiver Unit mounting bracket* on page 120
- *Junction Box – outline dimensions* on page 121
- *Transceiver Unit cable clamp* on page 122

Cable details

- *Generic RS-232 Serial line* on page 123
- *Generic coax cable* on page 124
- *Sound speed probe interface* on page 125
- *RS-232 or RS-422/485 serial line* on page 126
- *Trigger in/out (not used)* on page 127
- *Internal control signals* on page 128
- *Remote control and external trig* on page 129
- *Standard AC power cable* on page 130
- *Ethernet cable with RJ45* on page 131
- *VGA/SVGA Display cable* on page 132
- *USB cable* on page 133
- *Keyboard cable* on page 134
- *Mouse cable* on page 135
- *Parallel printer* on page 136
- *RX/TX transducer cables* on page 137

10.1 Installation Drawings

10.1.1 0.5° mounting frame assembly TX module

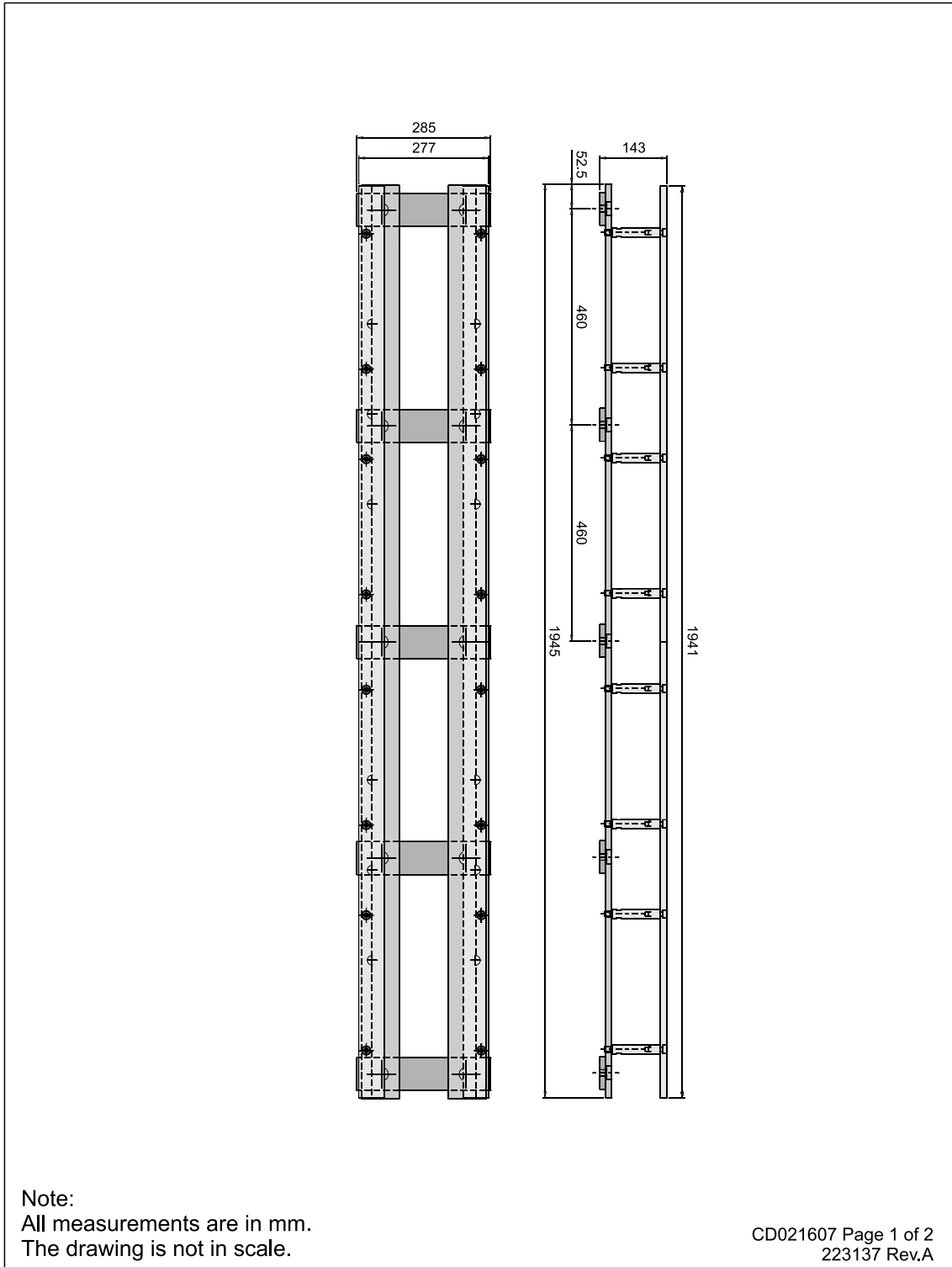

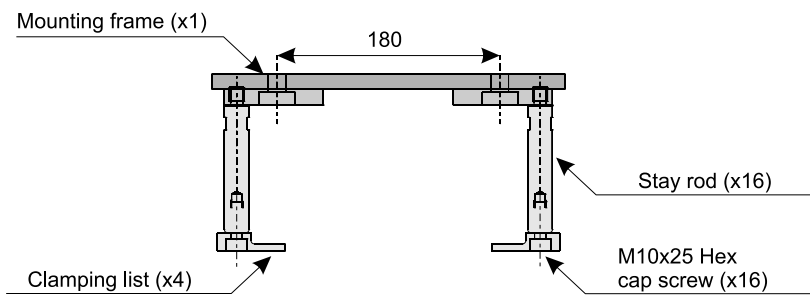

Note:
All measurements are in mm.
The drawing is not in scale.

Cd021607 Page 2 of 2
223137 Rev.A

10.1.2 1° mounting frame assembly RX module

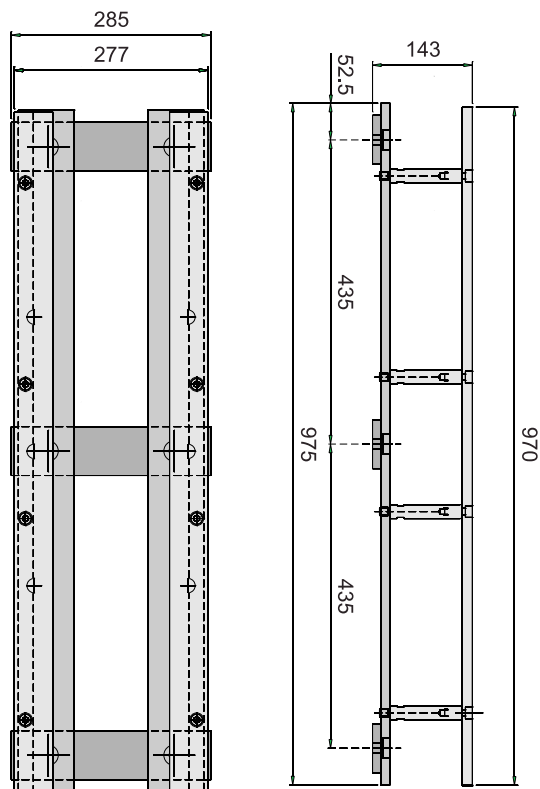

Note:
All measurements are in mm.
The drawing is not in scale.

Cd021608 Page 1 of 2
223139 Rev.B

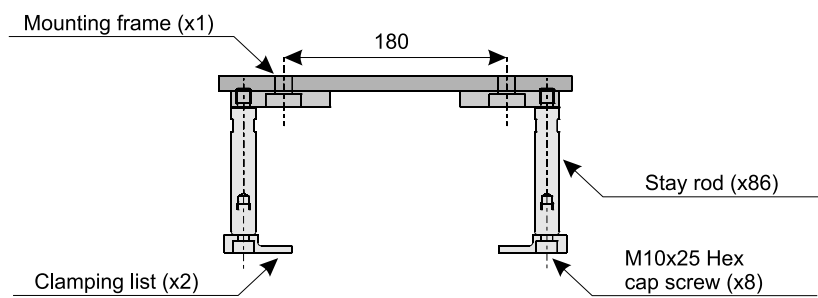

Note:
All measurements are in mm.
The drawing is not in scale.

Cd021608 Page 2 of 2
223139 Rev.B

10.1.3 2° mounting frame assembly TX/RX module

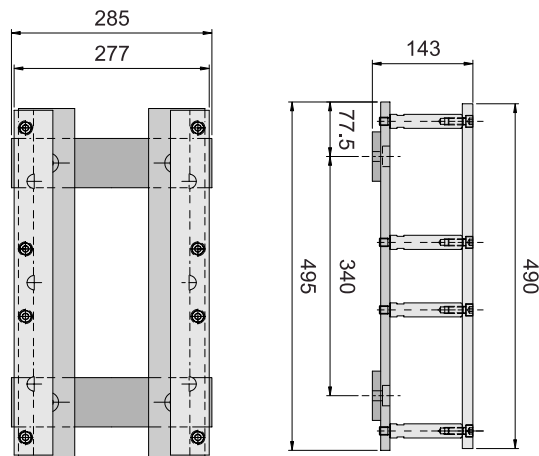

Note:
All measurements are in mm.
The drawing is not in scale.

CD021612 Page 1 of 2
223273 Rev.B

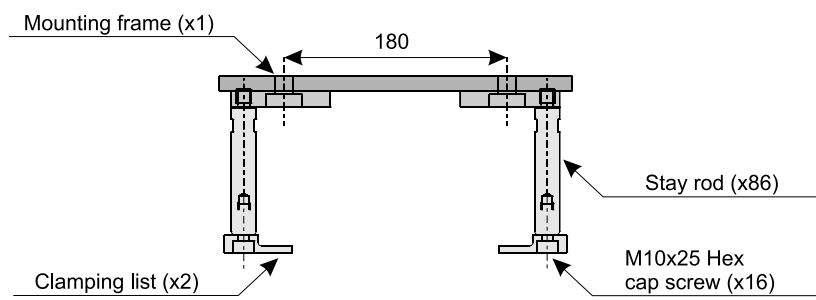

Note:
All measurements are in mm.
The drawing is not in scale.

CD021612 Page 2 of 2
223273 Rev.B

10.1.4 0.5 x 1° gondola

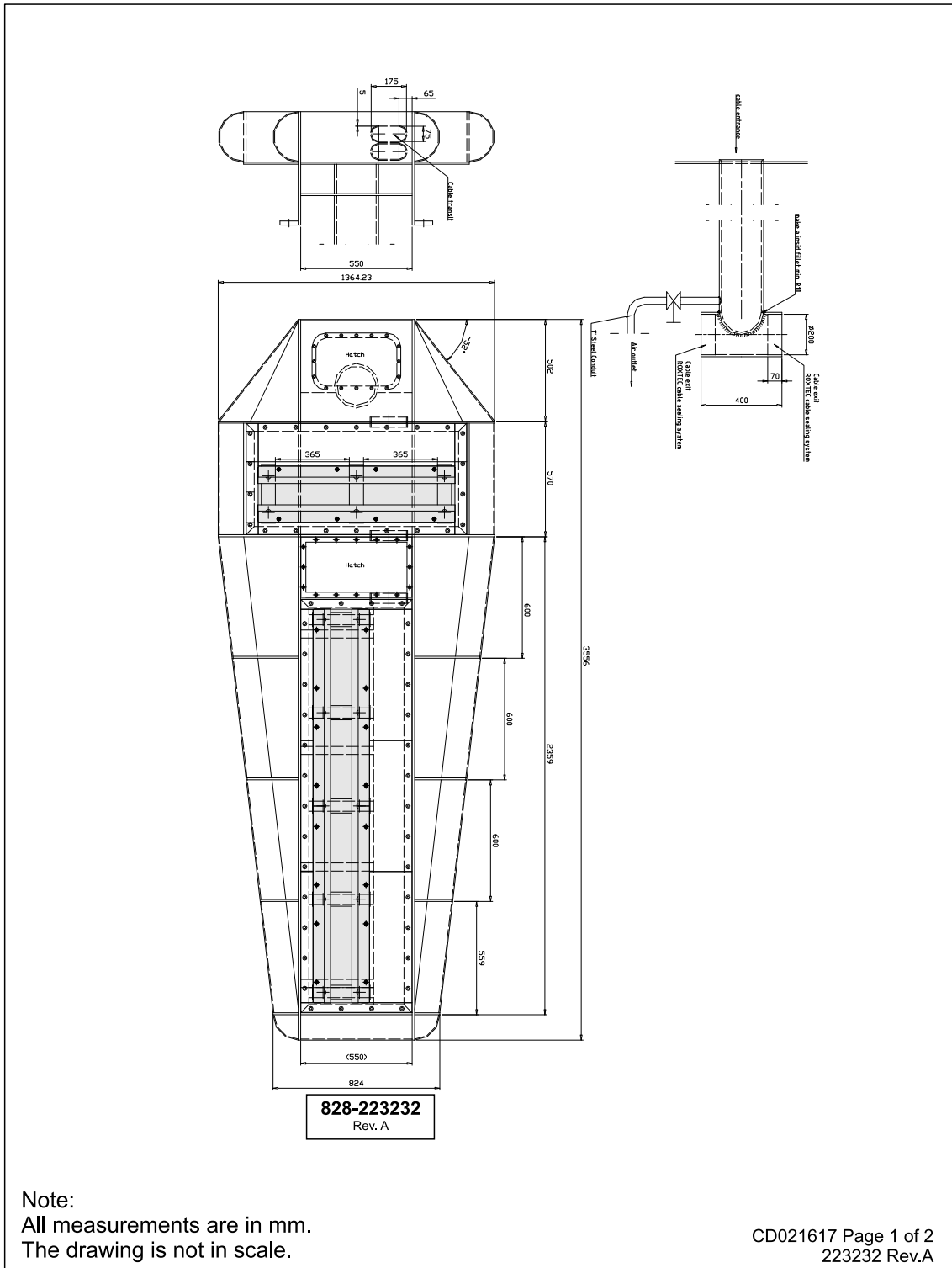

Note:
All measurements are in mm.
The drawing is not in scale.

CD021617 Page 1 of 2
223232 Rev.A

10.1.5 Transducer TX1 Outline dimensions

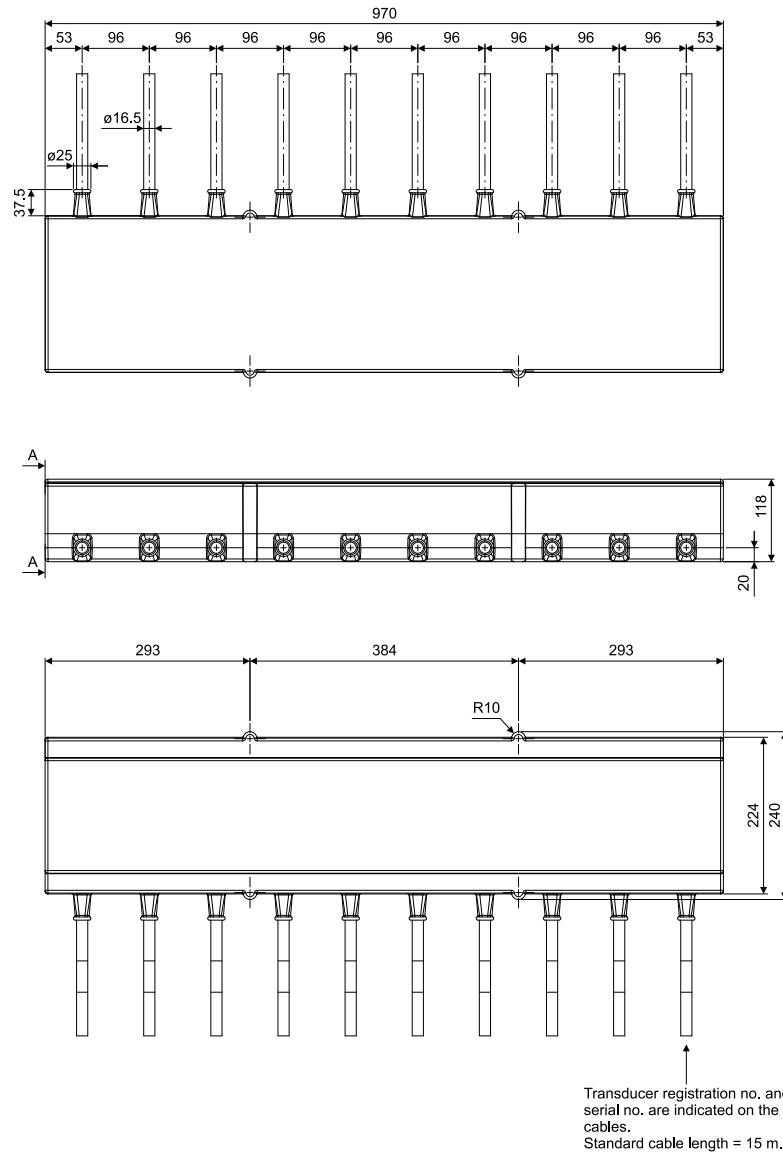

Note:
All measurements are in mm.
The drawing is not in scale.

Cd021603 Page 1 of 2
216148 Rev.A

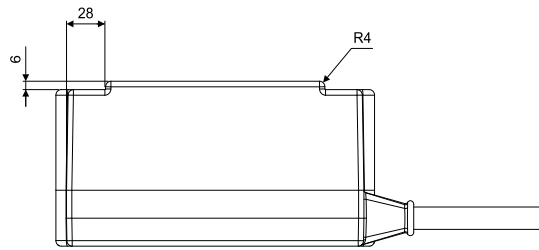

Section A-A

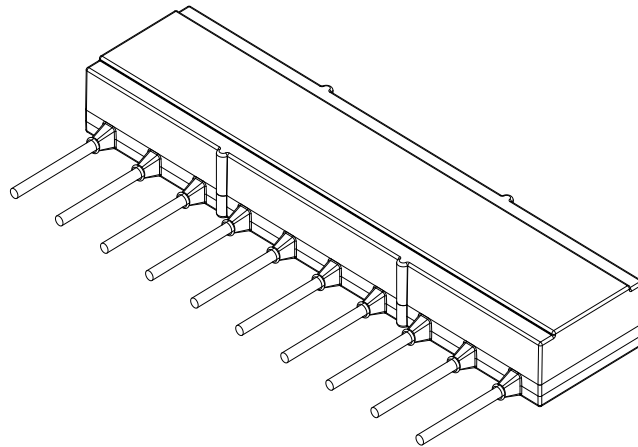

Note:
All measurements are in mm.
The drawing is not in scale.

Cd021603 Page 2 of 2
216148 Rev.A

10.1.6 Transducer TX2 Outline dimensions

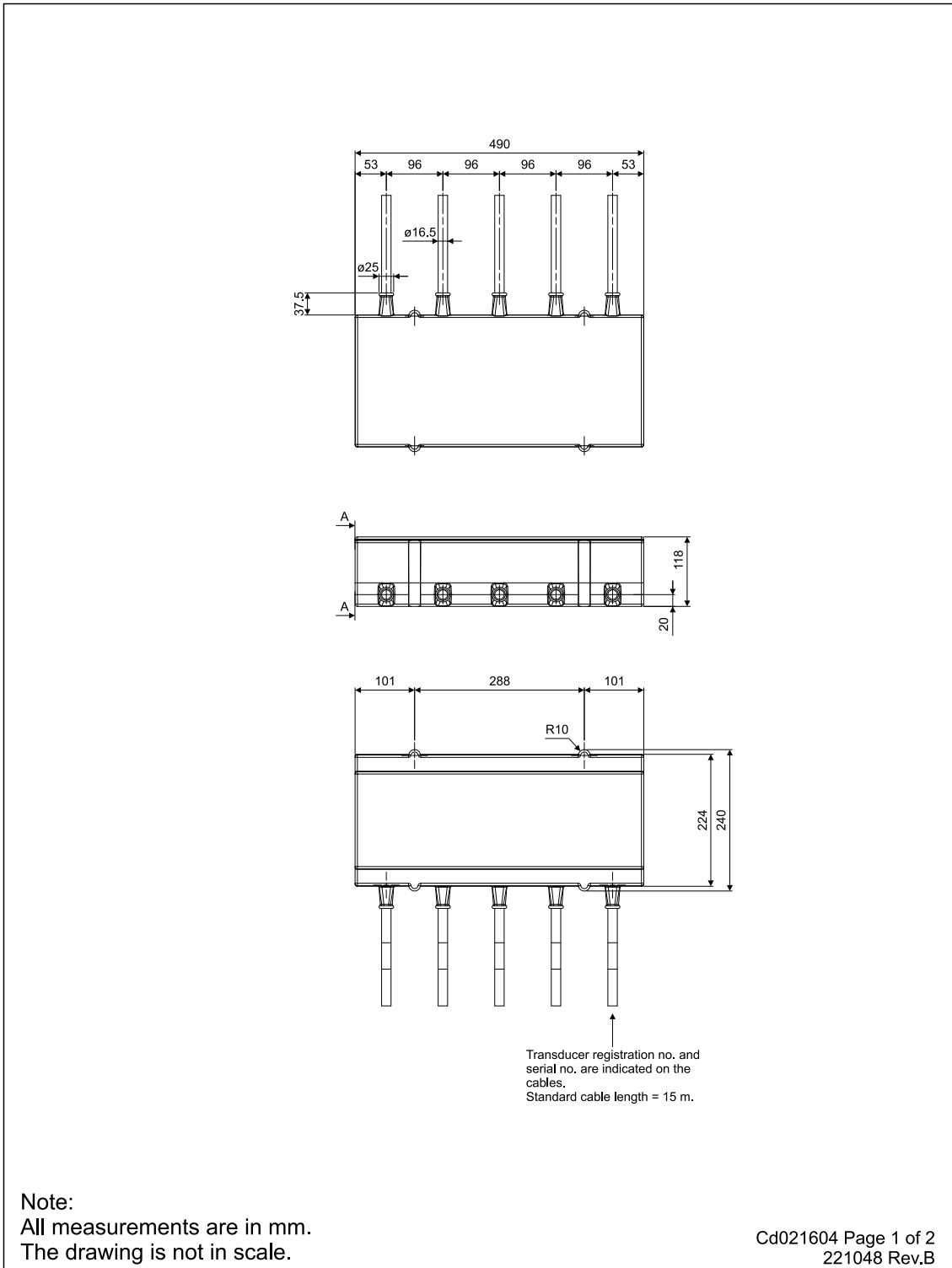

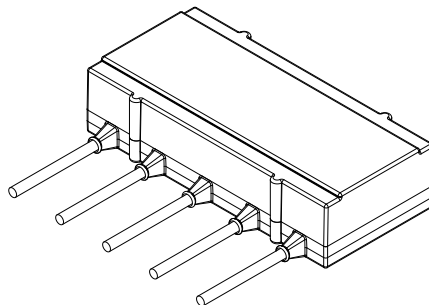
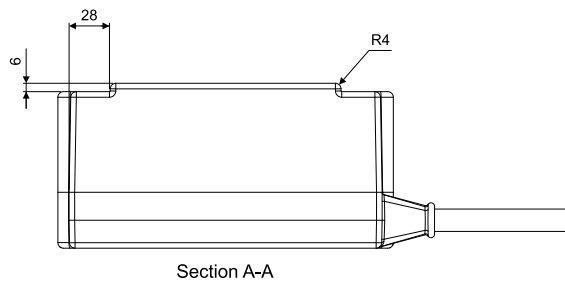

Note:
All measurements are in mm.
The drawing is not in scale.

Cd021604 Page 2 of 2
221048 Rev.B

10.1.7 Transducer RX1 Outline dimensions

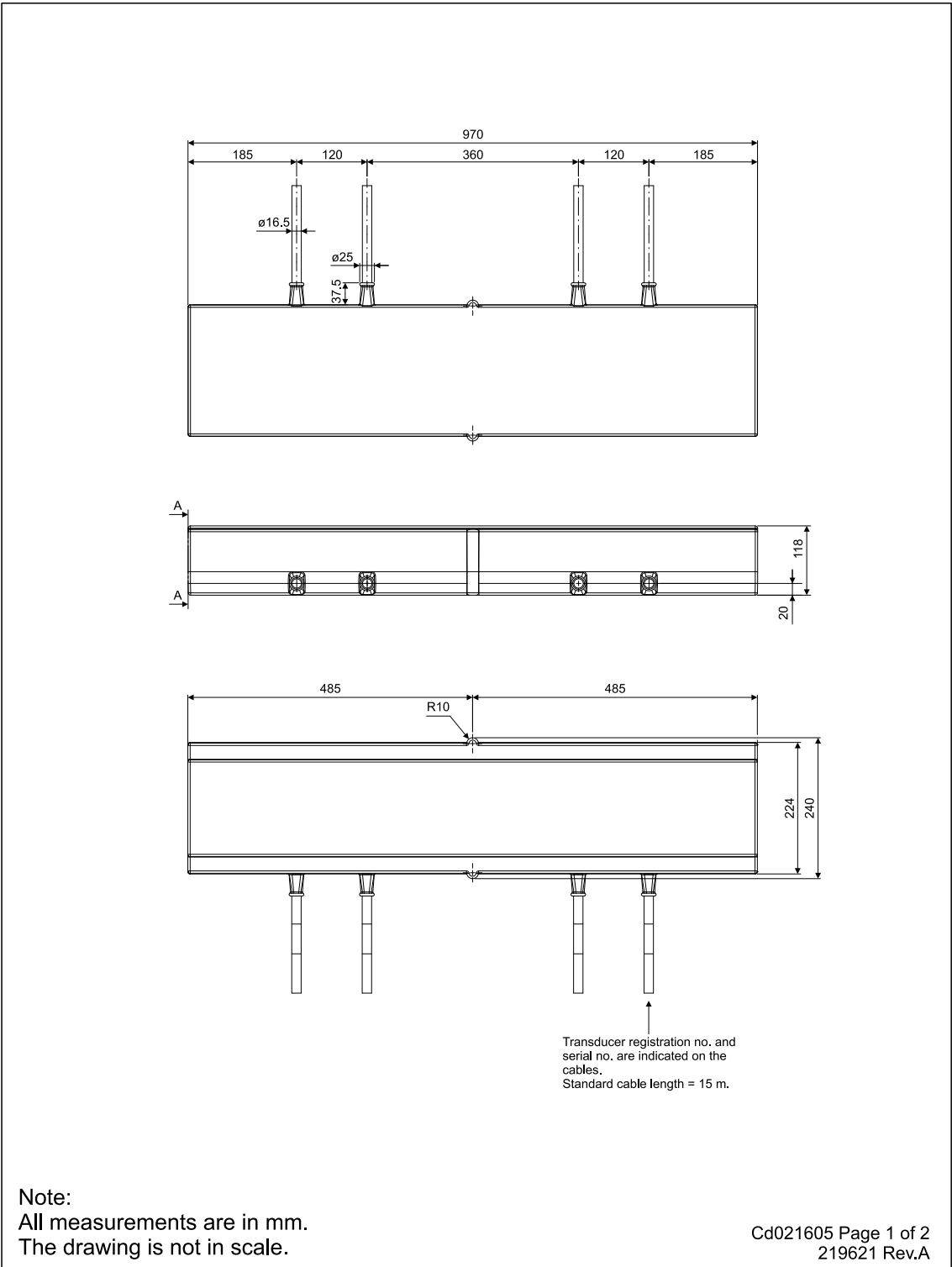

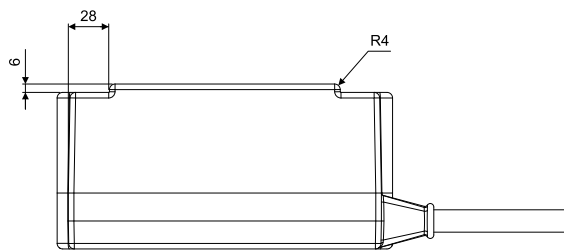

Section A-A

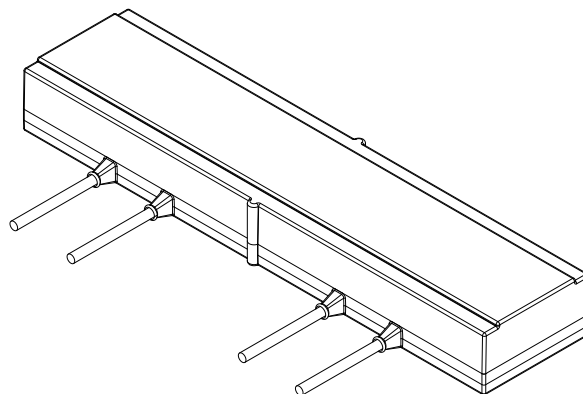

Note:
All measurements are in mm.
The drawing is not in scale.

Cd021605 Page 2 of 2
219621 Rev.A

10.1.8 Transducer RX2 Outline dimensions

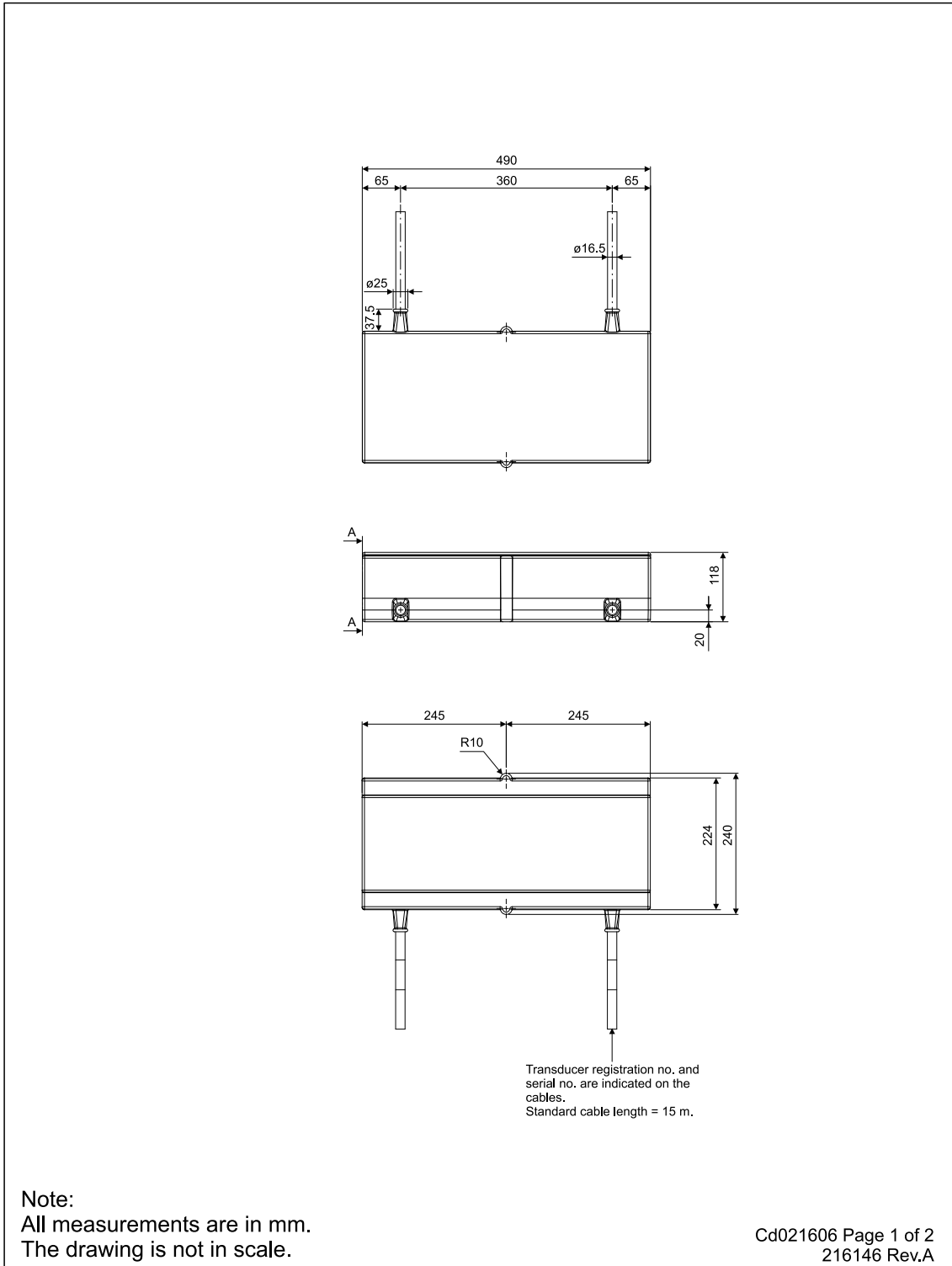

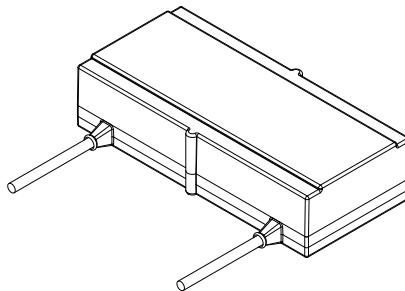
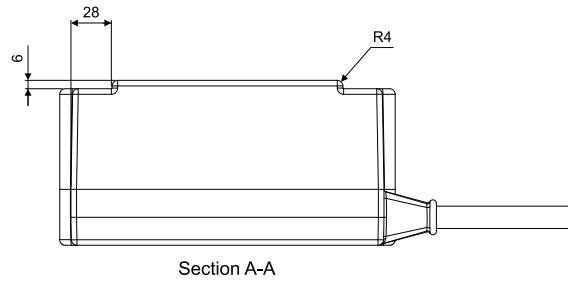

Note:
All measurements are in mm.
The drawing is not in scale.

CD021606 Page 2 of 2
216146 Rev.A

10.1.9 HWS Operator Station Outline dimensions



19" LCD:
Width = 483 mm
Height = 444 mm
Depth = 68 mm
Weight = 12 kg



HWS 19" Rack:
Width = 427 mm
Height = 180 mm/4U
Depth = 480 mm
Weight = 20 kg

Note:
All measurements are in mm.
The drawing is not in scale

Cd021046 Page 1 of 1
307181 Rev. A

10.1.10 Transceiver Unit Outline dimensions

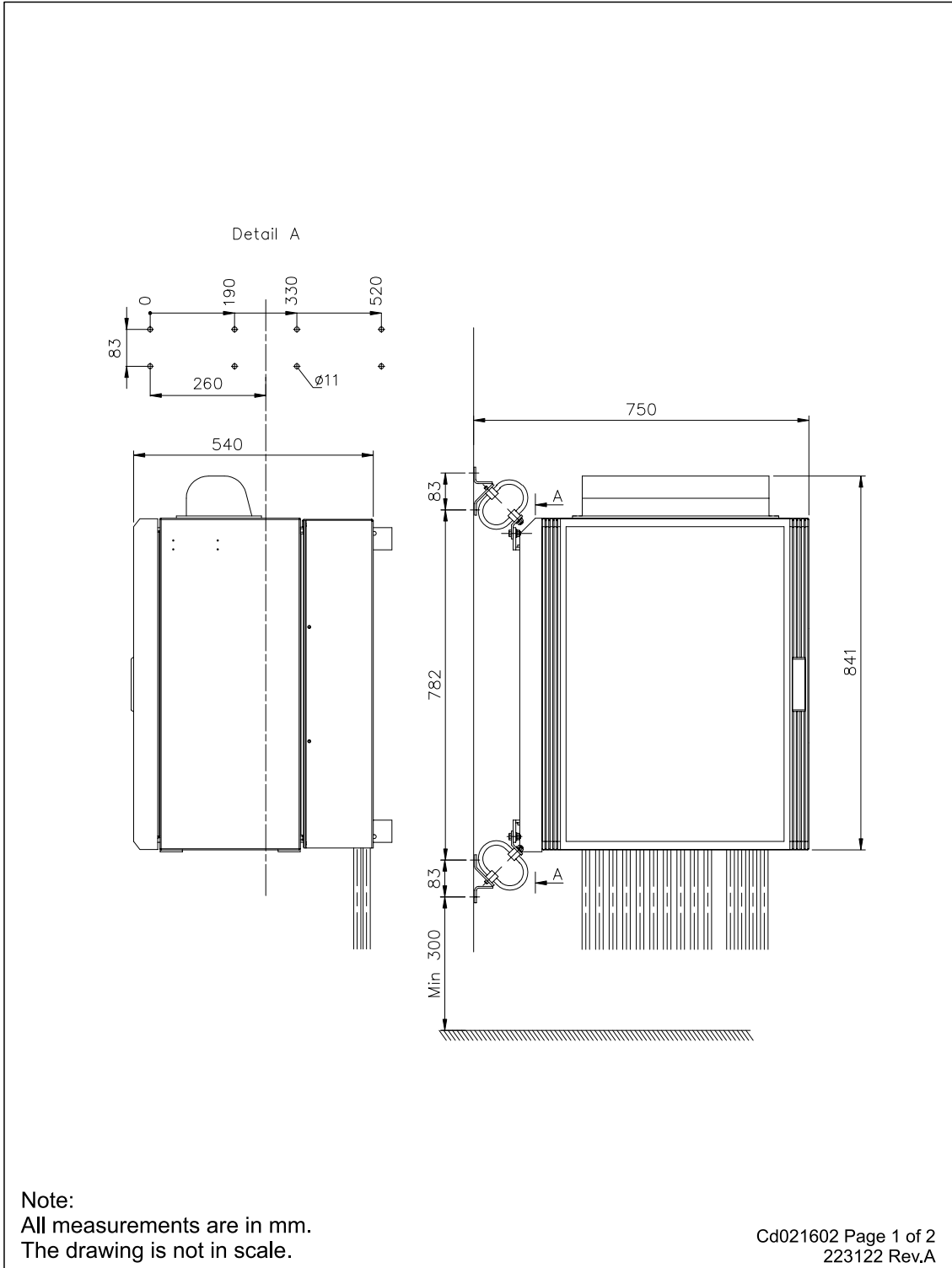

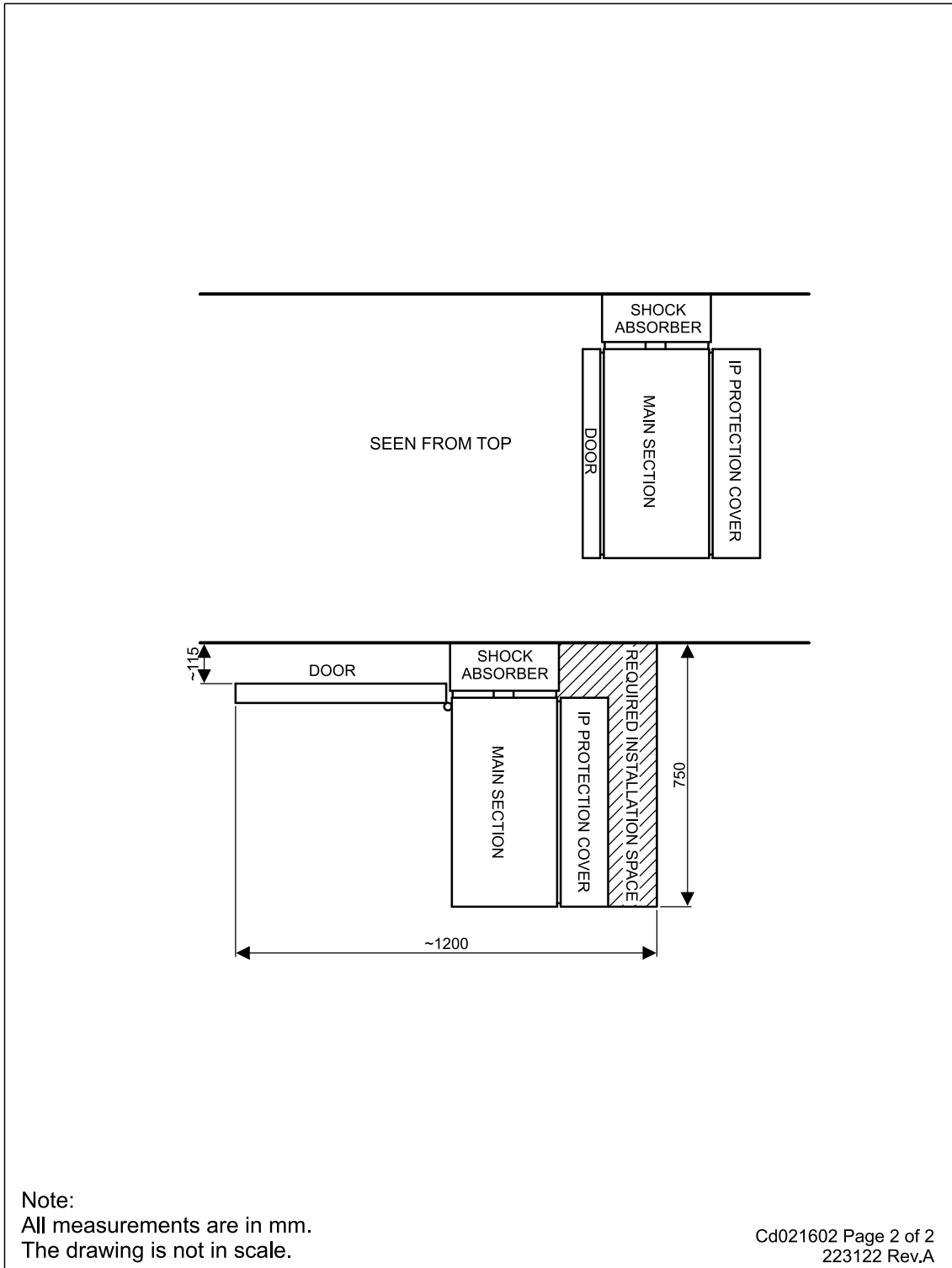

Note:
All measurements are in mm.
The drawing is not in scale.

Cd021602 Page 2 of 2
223122 Rev.A

10.1.11 Transceiver Unit 2 x 2 degree system – Outline dimensions

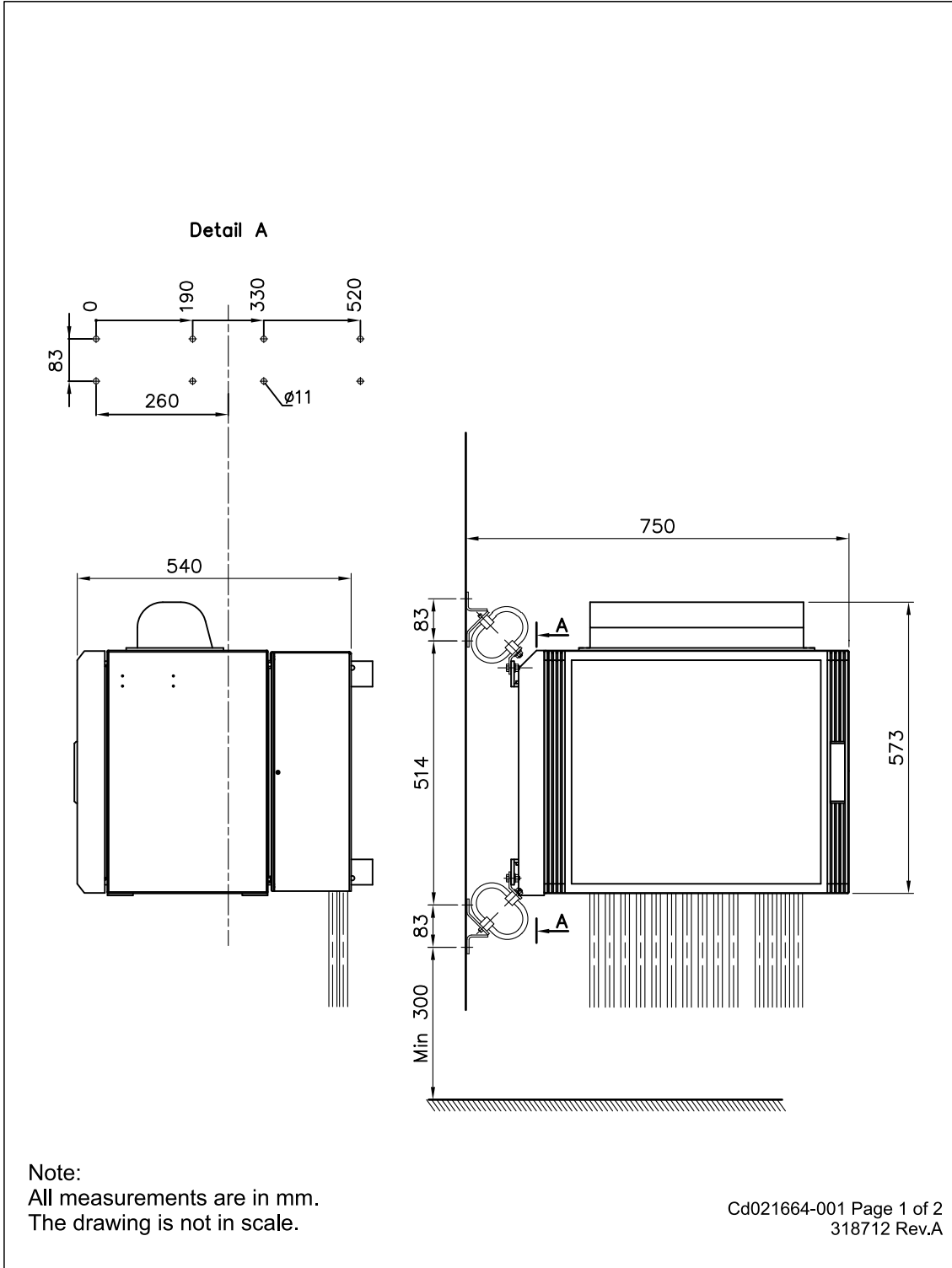

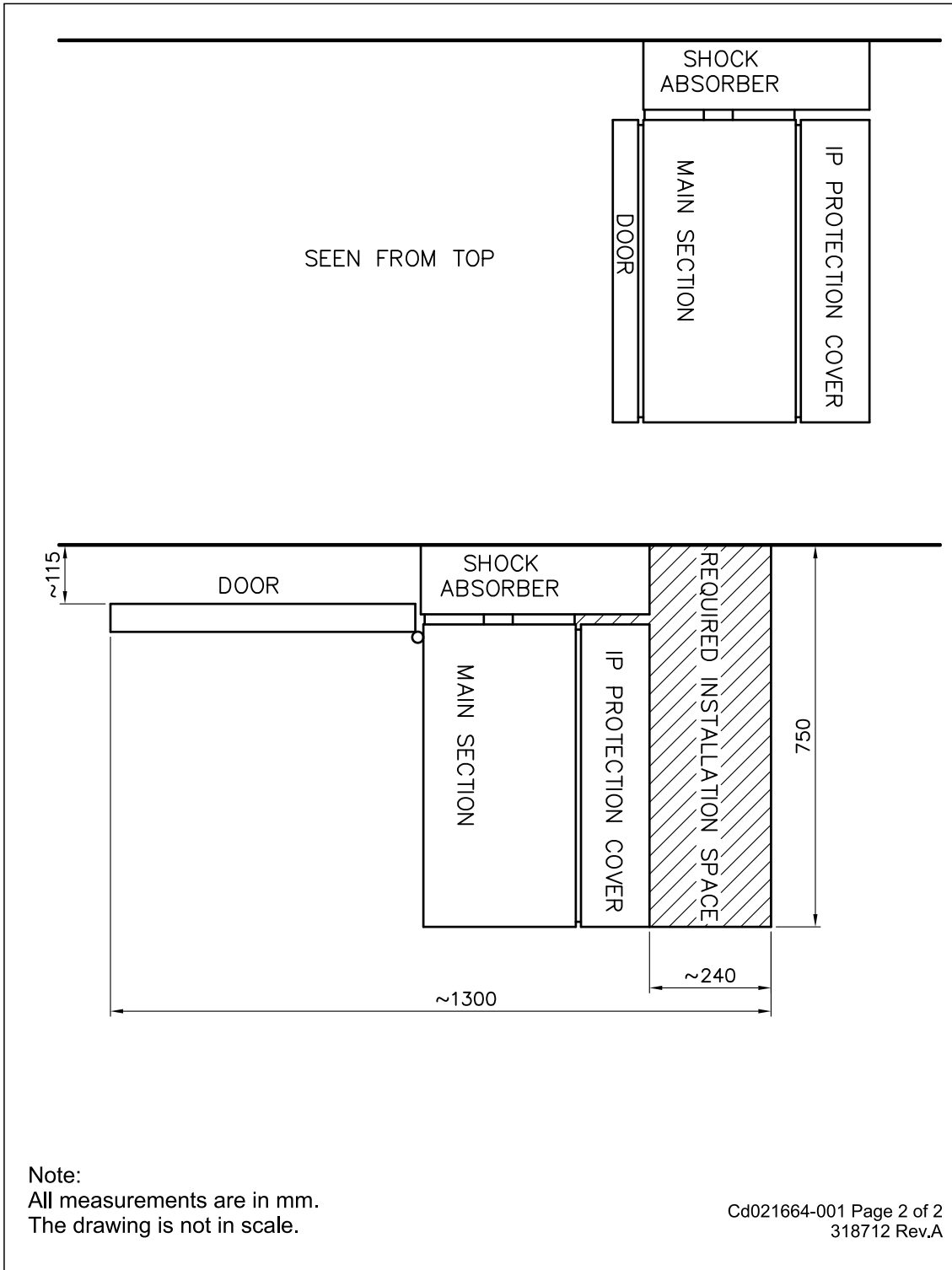

Note:
All measurements are in mm.
The drawing is not in scale.

10.1.12 Transceiver Unit mounting bracket

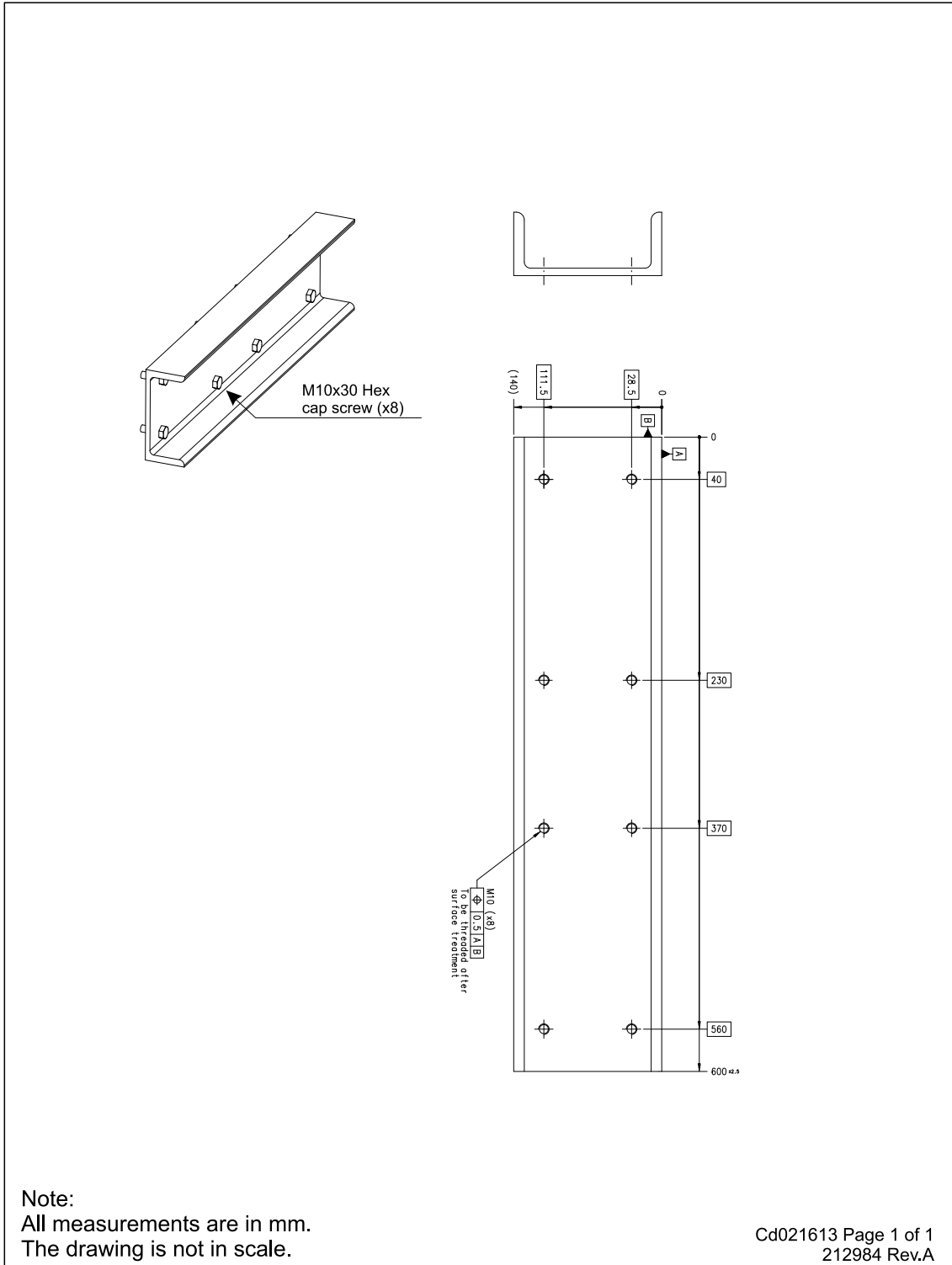

10.1.13 Junction Box – outline dimensions

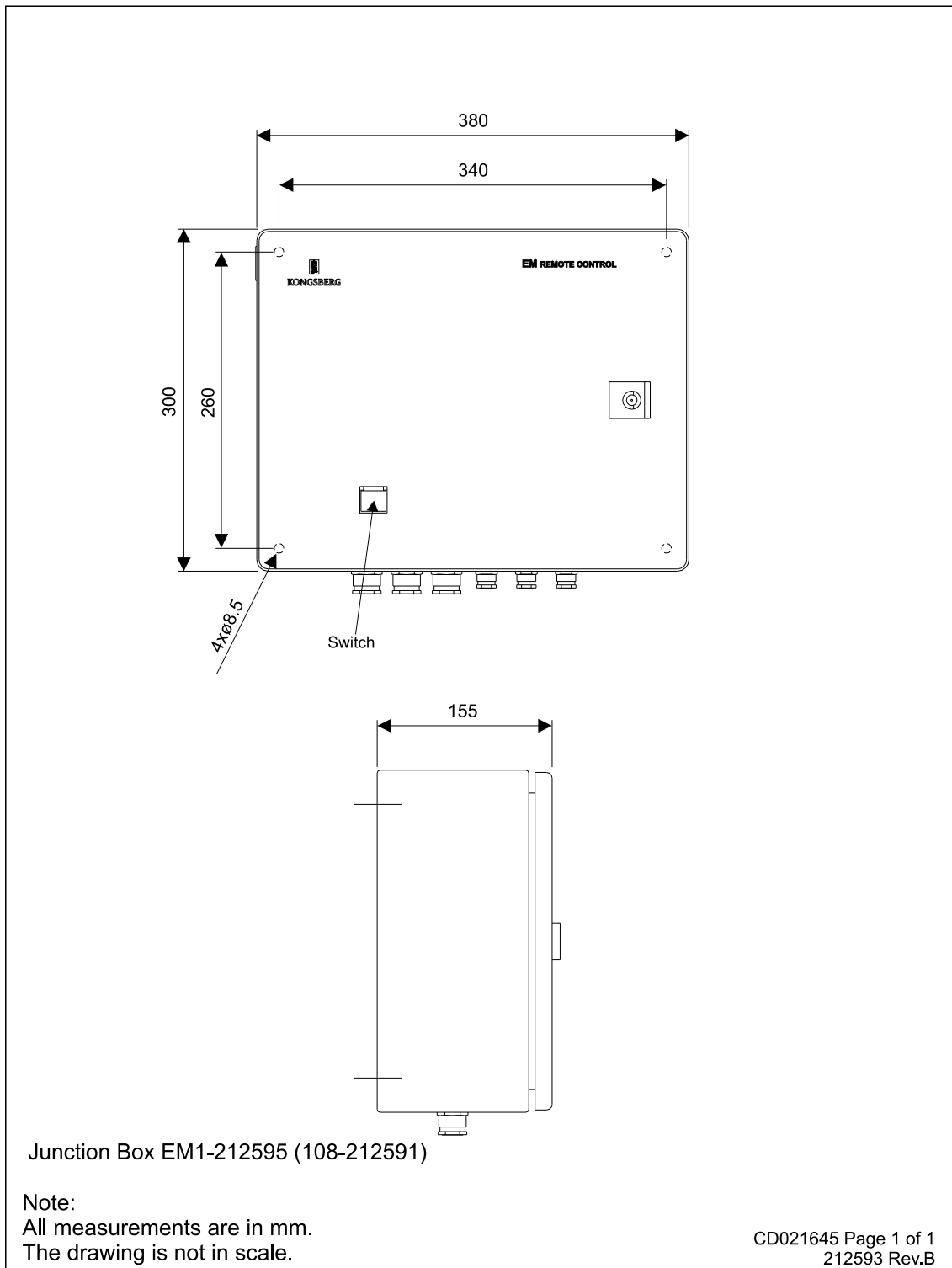

10.1.14 Transceiver Unit cable clamp

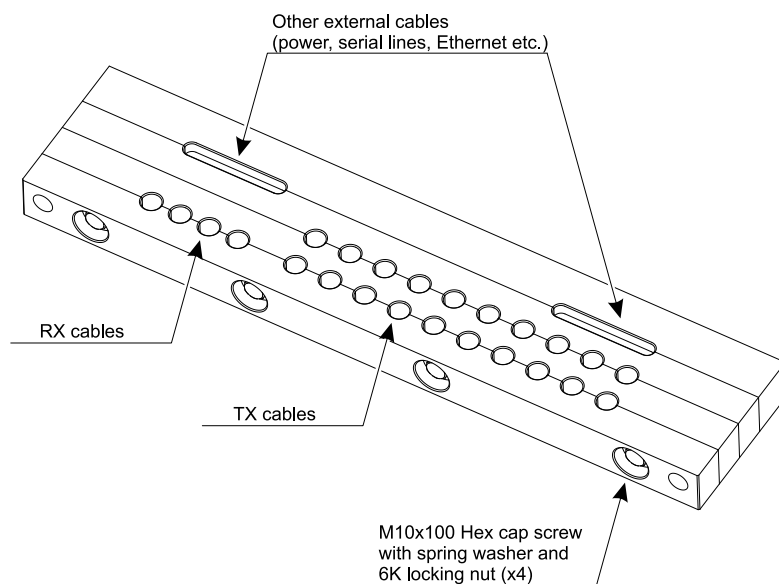

Note:
All measurements are in mm.
The drawing is not in scale.

Cd021614 Page 1 of 1
223163 Rev.A

10.2 Cable Drawings

10.2.1 Generic RS-232 Serial line

This cable comprises a multi purpose serial line. It provides interface with any peripheral unit. One end of the cable connects to the local unit (DTE) with a 9-pin D-connector, while the other connects to the peripheral (DCE) as described in the peripheral unit's documentation.

In many cases, only the **RXD**, **TXT** and **GND** pins are used. Twisted pairs are sufficient in the cable.

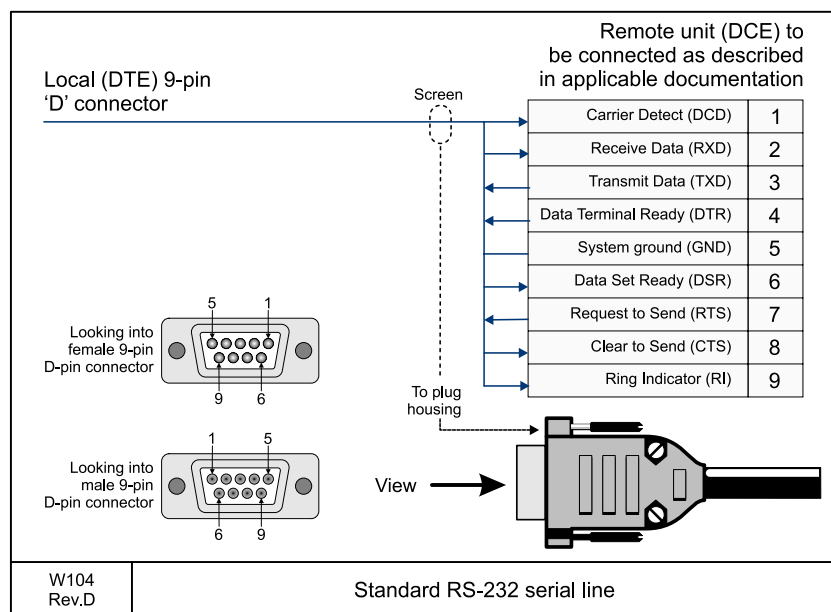

Cable specifications

- Conductors: 5 x 2 x 0.5 mm²
- Screen: Screened twisted pairs and overall braided
- Voltage: 60 V
- Maximum diameter: Limited by the plugs

10.2.2 Generic coax cable

This cable is used for connections to peripheral units or networks.

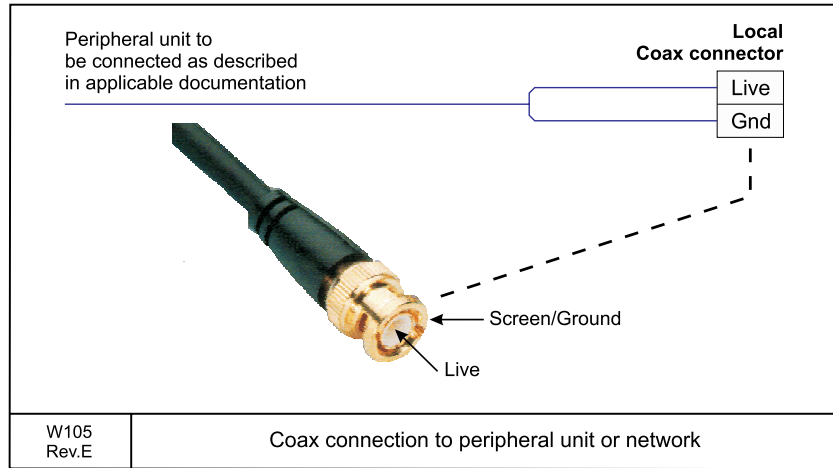

10.2.3 Sound speed probe interface

This cable provides the interconnection between the Processor Unit work station and the sound speed probe. This connection is normally made through a small junction box and with a power supply as indicated in the drawing.

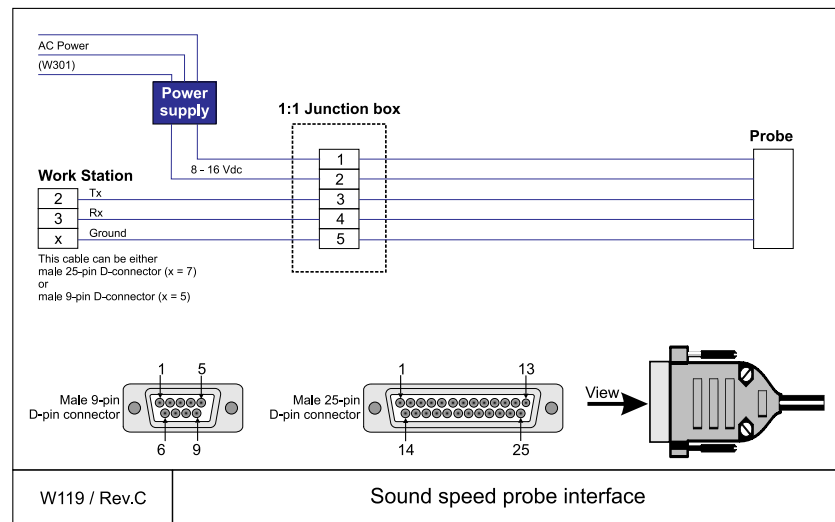

The cable between the junction box and the probe is supplied by the probe manufacturer.

- Conductors: 2 x 2 x 0.5 mm²
- Screen: Screened twisted pairs and overall braided
- Voltage: 60 V
- Maximum diameter: Limited by the plugs

10.2.4 RS-232 or RS-422/485 serial line

This cable comprises a multi-purpose serial line. It provides interface with any peripheral unit. One end of the cable connects to the local unit (DTE) with a 9-pin “D” connector, while the other connects to the peripheral (DCE) as described in the peripheral unit’s documentation.

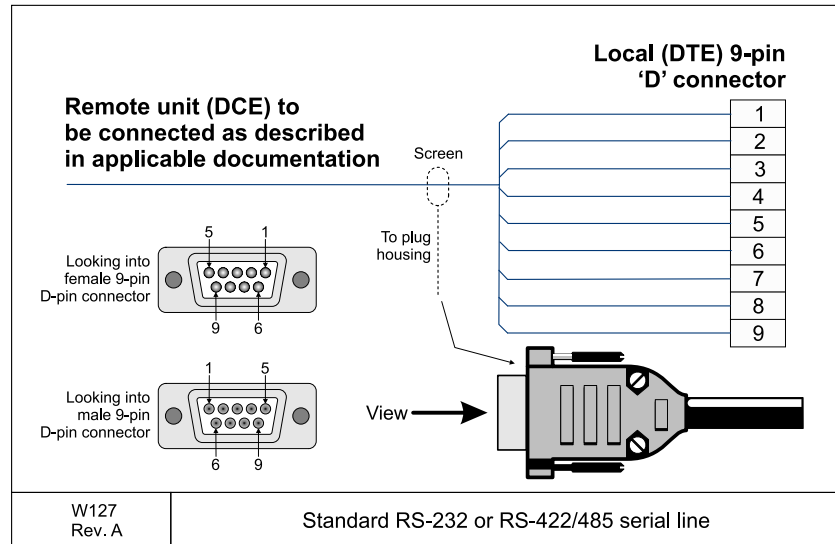

- Conductors: 6 x 2 x 0.5 mm²
- Screen: Screened twisted pairs and overall braided
- Voltage: 60 V
- Maximum diameter: Limited by the plugs

10.2.5 Trigger in/out (not used)

This cable is used to synchronize the echo sounder's transmissions with other acoustic instruments. It is terminated in a standard 9-pin D-sub connector at the Transceiver Unit end.

The cable is normally not used.

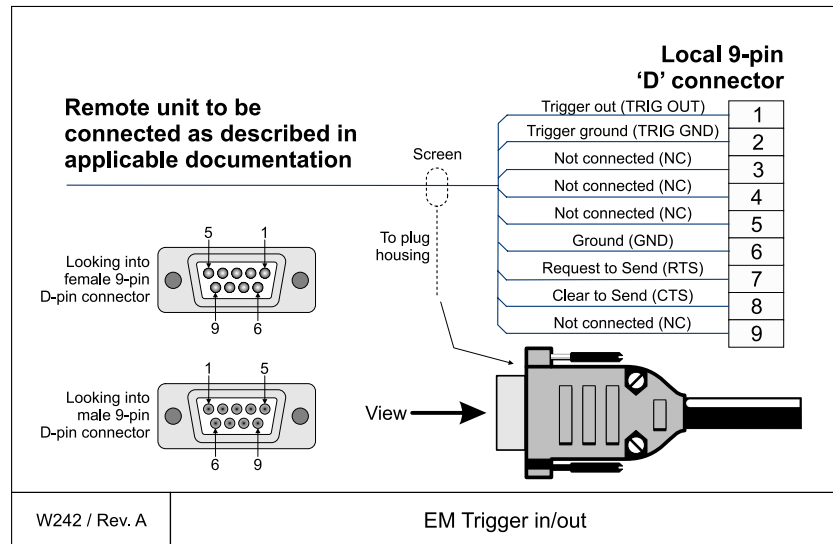

- Conductors: 5 x 2 x 0.5 mm²
- Screen: Screened twisted pairs and overall braided
- Voltage: 60 V
- Maximum diameter: Limited by the plugs

10.2.6 Internal control signals

This cable is used to transmit synchronization signals and TX enable signals. It is terminated in a standard 15-pin D-sub connector.

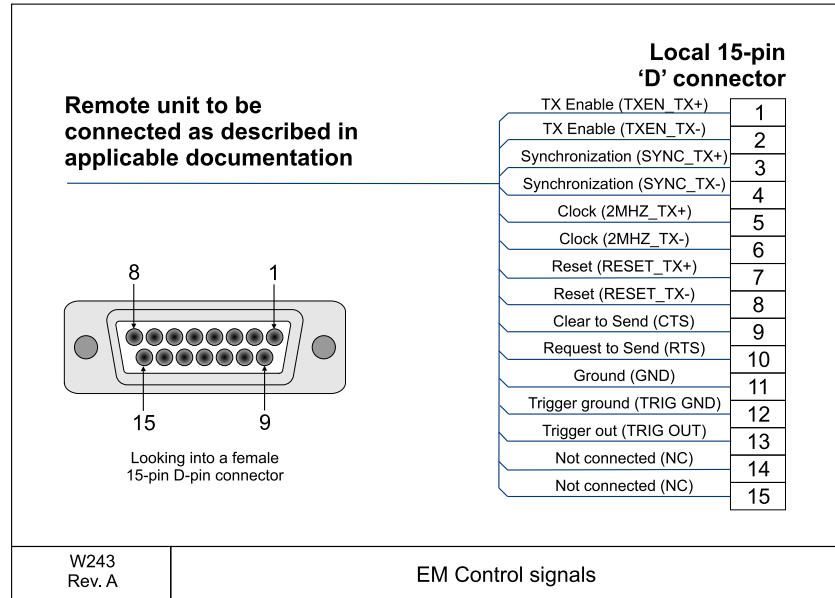

- Conductors: 9 x 2 x 0.5 mm²
- Screen: Screened twisted pairs and overall braided
- Voltage: 60 V
- Maximum diameter: Limited by the plugs

10.2.7 Remote control and external trig

This cable connects the EM 710 Transceiver Unit to a remote On/Off switch, normally located in a Remote Control junction box.

The same connection allows trigger output and remote control (synchronization) with a serial line.

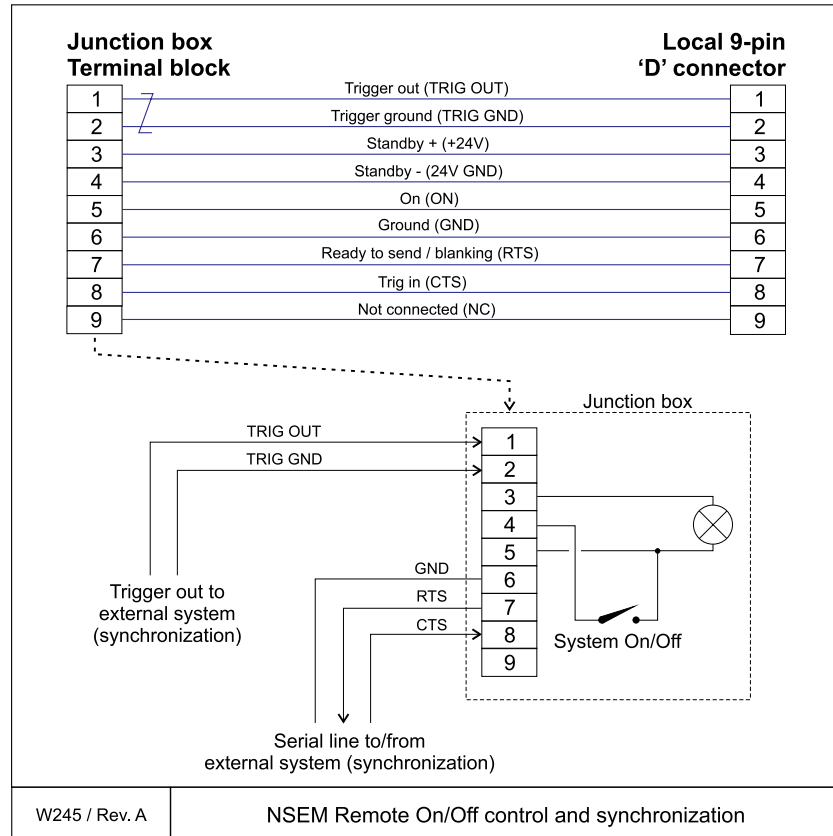

- Conductors: 5 x 2 x 0.5 mm²
- Screen: Overall braided
- Voltage: 60 V
- Maximum diameter: Limited by the plugs

10.2.8 Standard AC power cable

This cable is a standard three-wire power cable. The instrument end is terminated in a standard IEC female socket, while the other end is terminated in a plug suitable for the local standard.

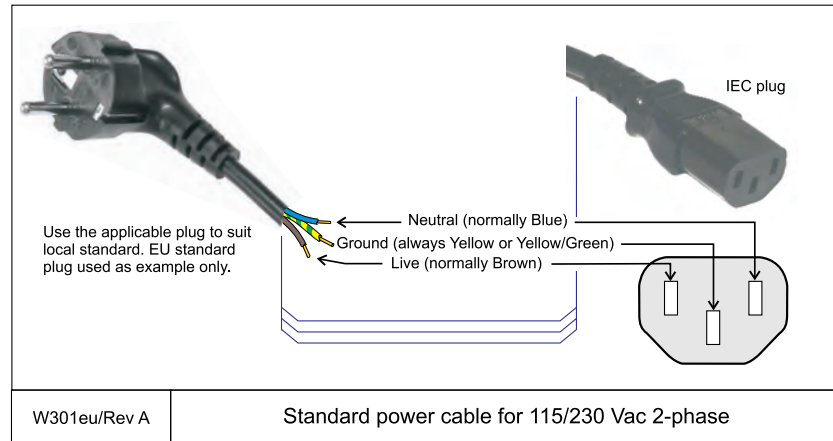

Note

*Different cable colours may be used for the **live** and **neutral** wires. Ground is however always on green/yellow.*

- Conductors: 3 x 1.5 mm²
- Screen: None
- Voltage: 750 V
- Maximum diameter: Defined by the manufacturer

10.2.9 Ethernet cable with RJ45

This cable is used to provide standard Ethernet connections. Note that various categories exist. **Cat.5 E** and **Cat.6** cables are used in local area networks with data rate exceeding 100 Mbit/s.

Ethernet cables are available commercially in different lengths, colours and categories.

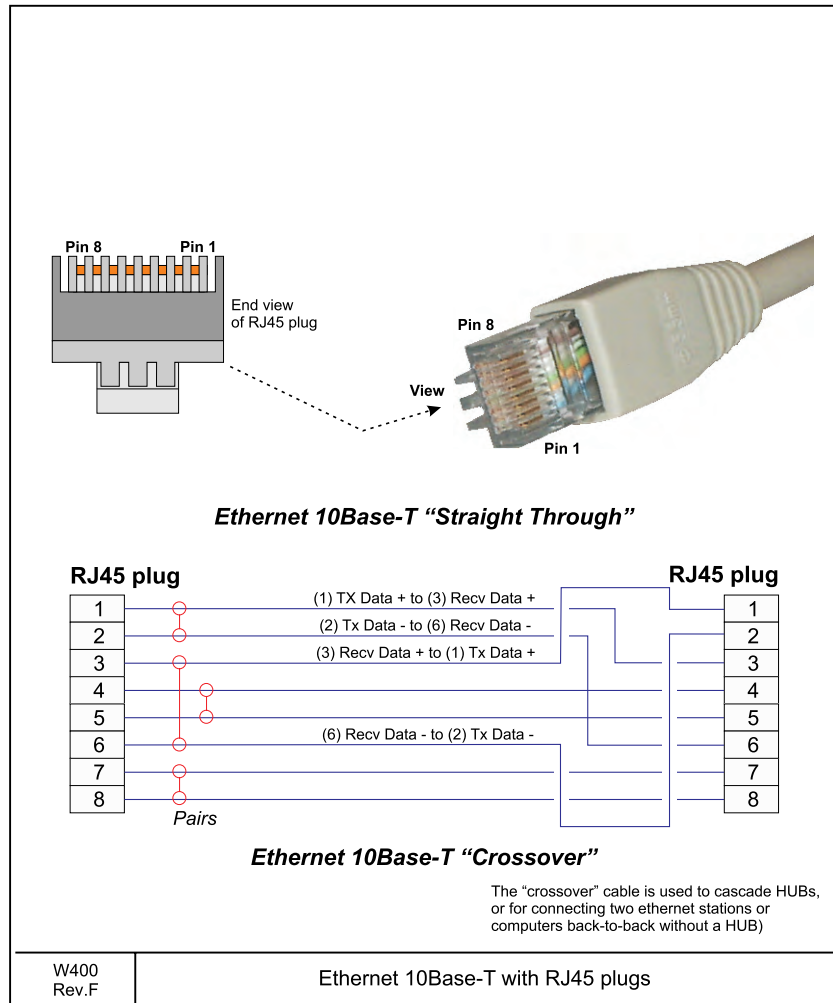

Screened category 6 (or 5 E) twisted pair cable to fit the specific RJ45 connectors used. AWG 23 and 24 size conductors are recommended.

10.2.10 VGA/SVGA Display cable

This is a standard commercial SVGA/VGA display cable used to connect the video signals. The cable is normally physically attached to the display monitor, and it is provided with the plug readily attached. If it is supplied as a separate cable, it is fitted with plugs on either end.

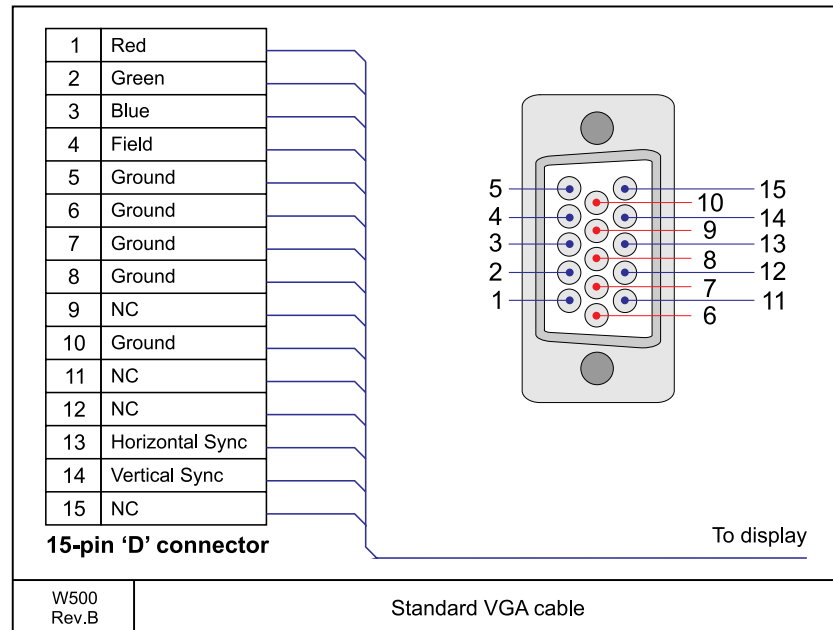

- Conductors: Defined by the manufacturer
- Screen: Defined by the manufacturer
- Voltage: Defined by the manufacturer
- Maximum diameter: Defined by the manufacturer
- Termination: Normally 15-pin D-connector(s)

10.2.11 USB cable

Just about any computer that you buy today comes with one or more Universal Serial Bus (USB) connectors on the back. These connectors let you attach everything from mouse to printers to your computer quickly and easily. Since the operating system supports USB, installation of device drivers is also easy.

In most cases, the USB cable is commercial, and they are normally supplied with the external devices, However, USB cables are also available commercially in different fixed lengths.

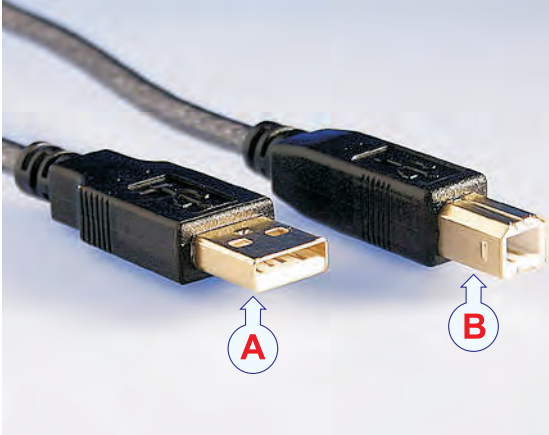
<p>Universal Serial Bus (USB) cable terminated with an A-plug in one end and a B-plug in the other.</p> <p>Internal cables:</p> <p>Pair 1: 28 AWG twisted pair (data, green, white)</p> <p>Pair 2: 20 AWG twisted pair (Power, red, black)</p> <p>Shield: Foil and braid</p>	
<p>W501 Rev.B</p>	<p>Commercial USB cable</p>

10.2.12 Keyboard cable

This is a standard keyboard cable. The cable is normally physically connected to the keyboard. It is terminated in a plug suited to fit the computer. Several keyboard types are available for different languages and hardware platforms. Both the keyboard and the attached cable are commercial items.

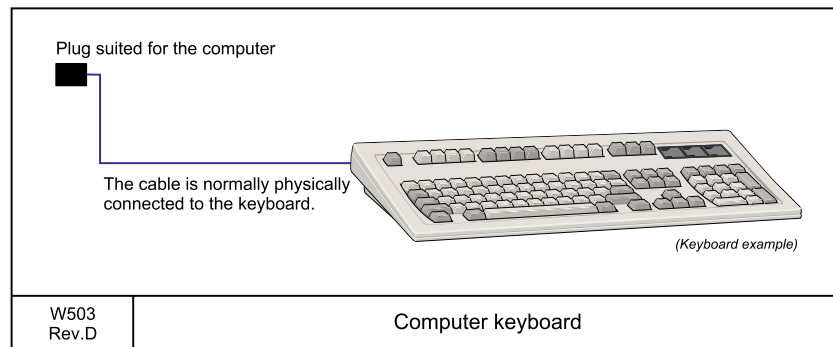

- Conductors: Defined by the manufacturer
- Screen: Defined by the manufacturer
- Voltage: Defined by the manufacturer
- Maximum diameter: Defined by the manufacturer
- Termination: USB, DIN or similar

10.2.13 Mouse cable

This is a standard mouse (or other pointing device) cable. It is physically connected to the mouse, and terminated in a plug suited to fit the computer. Several mouse and pointing device types are available with two or three buttons, and with or without a scroll wheel. Both the mouse and the attached cable are commercial items.

On Unix work stations, the mouse is normally connected to the keyboard.

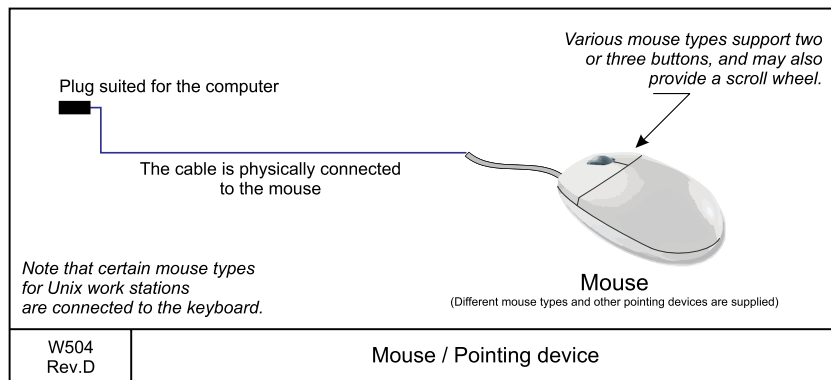

- Conductors: Defined by the manufacturer
- Screen: Defined by the manufacturer
- Voltage: Defined by the manufacturer
- Maximum diameter: Defined by the manufacturer
- Termination: USB, PS2 or similar

10.2.14 Parallel printer

This is a standard “Centronics” parallel printer cable. It is provided ready-made with printers, and also obtainable from commercial retailers.

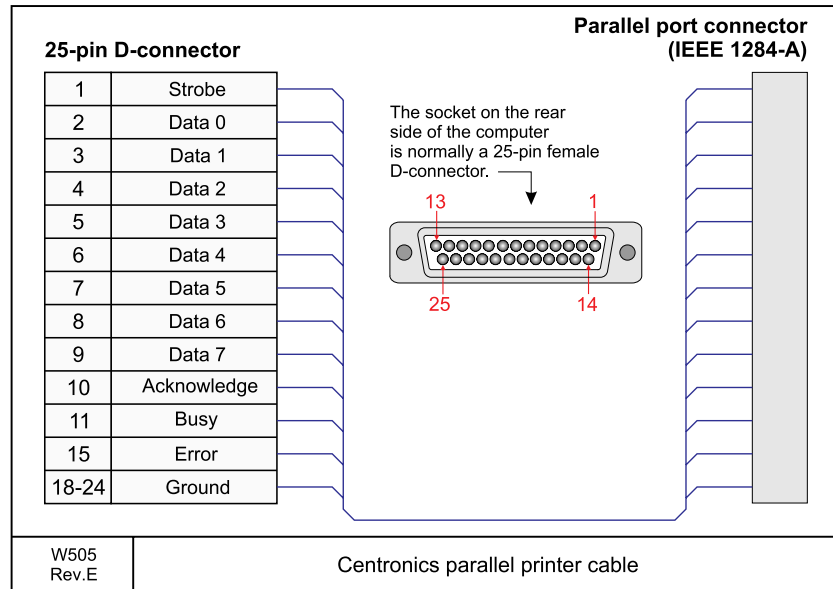

Cable specifications

- Conductors: Defined by the standard
- Screen: Defined by the cable manufacturer, normally overall braided
- Voltage: 60V
- Maximum diameter: Defined by the cable manufacturer
- Termination: 25-pin “D-sub” connector in one end, parallel port connector in the other end (IEEE 1284-A)

10.2.15 RX/TX transducer cables

These are the cables from the EM 710 Transceiver Unit to the RX/TX transducer arrays. Each cable is terminated at the cabinet's rear through a 78-pin D-sub connector. At the transducer end, the cables are moulded to their respective arrays. The cables are supplied by manufacturer.

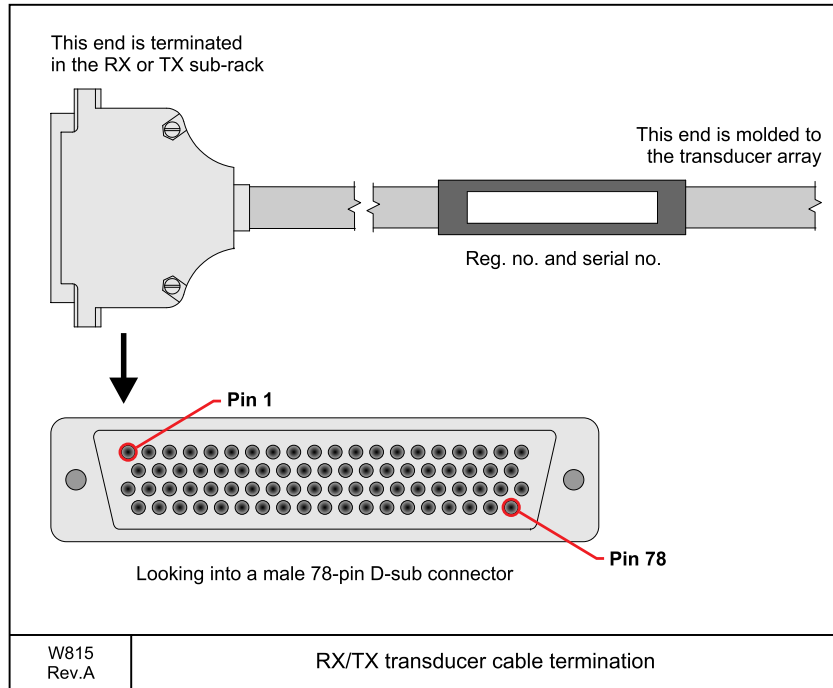

The following table displays the pin assignment in the transducer cable from the RX RIO board in the Transceiver Unit to the RX transducer

Table 12 RX transducer cable pin assignment

Module no.	Element no.	Pin no.		Wire colour code	
1	1	1	21	White	Brown
1	2	40	60	Green	Yellow
1	3	2	22	Grey	Pink
1	4	41	61	Blue	Red
1	5	3	23	Black	Violet
1	6	42	62	Grey/pink	Red/blue
1	7	4	24	White/green	Brown/green
1	8	43	63	White/yellow	Yellow/brown
1	9	5	25	White/grey	Grey/brown
1	10	44	64	White/pink	Pink/brown
1	11	6	26	White/blue	Brown/blue
1	12	45	65	White/red	Brown/red

Table 12 RX transducer cable pin assignment (cont'd.)

Module no.	Element no.	Pin no.		Wire colour code	
1	13	7	27	White/black	Brown/black
1	14	46	66	Grey/green	Yellow/grey
1	15	8	28	Pink/green	Yellow/pink
1	16	47	67	Green/blue	Yellow/blue
2	1	9	29	Grey/blue	Pink/blue
2	2	48	68	Grey/red	Pink/red
2	3	10	30	Grey/black	Pink/black
2	4	49	69	Blue/black	Red/black
2	5	11	31	White	Brown
2	6	50	70	Green	Yellow
2	7	12	32	Grey	Pink
2	8	51	71	Blue	Red
2	9	13	33	Black	Violet
2	10	52	72	Grey/pink	Red/blue
2	11	14	34	White/green	Brown/green
2	12	53	73	White/yellow	Yellow/brown
2	13	15	35	White/grey	Grey/brown
2	14	54	74	White/pink	Pink/brown
2	15	16	36	White/blue	Brown/blue
2	16	55	75	White/red	Brown/red

The following table displays the pin assignment in the transducer cable from the TX RIO board in the Transceiver Unit to the TX transducer.

Table 13 TX transducer cable pin assignment

Element no.	Pin no.		Wire colour code	
1	1	21	White	Brown
2	2	22	Green	Yellow
3	3	23	Grey	Pink
4	4	24	Blue	Red
5	5	25	Black	Violet
6	6	26	Grey/pink	Red/blue
7	7	27	White/green	Brown/green
8	8	28	White/Yellow	Yellow/brown
9	9	29	White/grey	Grey/brown
10	10	30	White/pink	Pink/brown
11	11	31	White/blue	Brown/blue
12	12	32	White/red	Brown/red

Table 13 TX transducer cable pin assignment (cont'd.)

Element no.	Pin no.		Wire colour code	
13	13	33	White/black	Brown/black
14	14	34	Grey/green	Yellow/grey
15	15	35	Pink/green	Yellow/pink
16	16	36	Green/blue	Yellow/blue
17	17	37	Green/red	Yellow/red
18	18	38	Green/black	Yellow/black
19	40	60	Grey/blue	Pink/blue
20	41	61	Grey/red	Pink/red
21	42	62	Grey/black	Pink/black
22	43	63	Blue/black	Red/black
23	44	64	White	Brown
24	45	65	Green	Yellow
25	46	66	Grey	Pink
26	47	67	Blue	Red
27	48	68	Black	Violet
28	49	69	Grey/pink	Red/blue
29	50	70	White/green	Brown/green
30	51	71	White/yellow	Yellow/brown
31	52	72	White/grey	Grey/brown
32	53	73	White/pink	Pink/brown
33	54	74	White/blue	Brown/blue
34	55	75	White/red	Brown/red
35	56	76	White/black	Brown/black
36	57	77	Grey/green	Yellow/grey

©2009 Kongsberg Maritime

Kongsberg Maritime AS

Strandpromenaden 50
P.O.Box 111
N-3191 Horten,
Norway

Telephone: +47 33 02 38 00
Telefax: +47 33 04 47 53
www.kongsberg.com
subsea@kongsberg.com



KONGSBERG

**EM 710 Multibeam echo sounder
Maintenance manual - Base version**

**EM 710 Multibeam echo sounder
Maintenance manual - Base version**

**EM 710 Multibeam echo sounder
Maintenance manual - Base version**